



*Dedicated to  
Satisfying our Community's  
Water Needs*

**AGENDA  
MESA WATER DISTRICT  
BOARD OF DIRECTORS  
Tuesday, October 15, 2019  
1965 Placentia Avenue, Costa Mesa, CA 92627  
3:30 p.m. Special Board Meeting**

---

**ENGINEERING AND OPERATIONS COMMITTEE MEETING  
Tuesday, October 15, 2019 at 3:30 p.m.**

**CALL TO ORDER**

**PLEDGE OF ALLEGIANCE**

**PUBLIC COMMENTS**

**Items Not on the Agenda:** Members of the public are invited to address the Board on items which are not on the agenda. Each speaker is limited to three minutes. The Board will set aside 30 minutes for public comments.

**Items on the Agenda:** Members of the public may comment on agenda items before action is taken, or after the Board has discussed the item. Each speaker is limited to three minutes. The Board will set aside 60 minutes for public comments.

**CONSENT CALENDAR ITEMS:**

*Approve all matters under the Consent Calendar by one motion unless a Board member, staff, or a member of the public requests a separate action.*

1. Developer Project Status Report
2. Mesa Water and Other Agency Projects Status Report
3. Water Quality Call Report
4. Committee Policy & Resolution Review
5. Water Operations Status Report

**ACTION ITEMS:**

*Items recommended for approval at this meeting may be agendaized for approval at a future Board meeting.*

6. Water Supply Assessment for the One Metro West Project
7. City of Costa Mesa Application for the California Emergency Solutions and Housing Program

**PRESENTATION AND DISCUSSION ITEMS:**

None



## REPORTS:

8. Report of the General Manager
9. Directors' Reports and Comments

## INFORMATION ITEMS:

10. Reservoirs 1 & 2 Chemical Management System

*In compliance with California law and the Americans with Disabilities Act, if you need disability-related modifications or accommodations, including auxiliary aids or services in order to participate in the meeting, or if you need the agenda provided in an alternative format, please contact the District Secretary at (949) 631-1206. Notification 48 hours prior to the meeting will enable Mesa Water District (Mesa Water) to make reasonable arrangements to accommodate your requests.*

*Members of the public desiring to make verbal comments utilizing a translator to present their comments into English shall be provided reasonable time accommodations that are consistent with California law.*

*Agenda materials that are public records, which have been distributed to a majority of the Mesa Water Board of Directors (Board), will be available for public inspection at the District Boardroom, 1965 Placentia Avenue, Costa Mesa, CA and on Mesa Water's website at [www.MesaWater.org](http://www.MesaWater.org). If materials are distributed to the Board less than 72 hours prior or during the meeting, the materials will be available at the time of the meeting.*

## ADJOURNMENT

## DEVELOPER PROJECT STATUS REPORT

PROJECT STATUS - DEVELOPER PROJECTS			
FILE NO.	PROJECT ADDRESS	PROJECT DESCRIPTION	PROJECT NOTES/STATUS
MC 2235	671 W 17th Street	177 Condos	<p>Plans received and plan check fees paid on 1/21/16. Hydraulic model initiated 2/24/16. Second plan check submitted on 3/24/16 and picked up 4/17/16. Mylar drawings and fee payment received on 7/5/16. Permit issued on 7/11/16. Demolition of existing services on 8/16/16. Mainline installation on 12/6/16. Service laterals installed on 1/9/17. Pressure test on 2/6/17. Bac-t test on 2/15/17. Bedding and service line placement on 4/3/17. Meter box placement on 5/8/17. Follow-up site visit on 5/17/17. Service abandonment on 8/30/17. Valve cans raised on 9/22/17. Meter box placement on 10/19/17. Gravel base on 12/5/17. Meter box placement on 2/14/18. Meters installed and locked off on 6/1/18, 7/17/18, on 8/1/18, and again on 9/7/18. Backflow tested on 9/11/18. Meters installed and locked off on 9/18/18, 9/25/18, and again on 10/5/18. Backflow tested on 10/9/18 and again on 2/27/19. Meters installed and locked off on 11/27/18, 12/5/18, 12/18/18, 1/10/19, 2/8/19, 2/21/19, 3/4/19, 3/12/19, again on 4/26/19. Phase 2 construction still on-going.</p>
C0056-18-01	2033 Republic Avenue	Single Family Home Service & Meter Upgrade	<p>Plans received and plan check fees paid on 6/19/18. Comments returned for second plan check review on 6/28/18. Second plan check submitted 7/26/18, and redlines picked up on 8/20/18. Third plan check submitted on 12/13/18, and redlines picked up on 1/15/19. Fourth and final plan check submitted on 1/24/19, and redlines picked up on 1/29/19. Final approval by District Engineer on 4/18/19. Final permit fees paid on 4/18/19. Permit issued on 4/30/19. Revised drawings issued 7/1/19 and returned 7/1/19.</p>
C0058-19-01	585 & 595 Anton Boulevard (P2)	Apartment Complex	<p>Plans received and plan check fees paid on 2/5/19. Customer picked up redlines on 2/8/19. Second plan check submitted 3/11/19, and redlines picked up on 3/25/19. Hydraulic Analysis received on 4/5/19. Received Water Service Agreement on 4/30; Final permit fees paid on 5/8/19. Permit issued on 5/8/19. Precon meeting held on 5/16/19. Waiting for revised Easements and Quit Claims regarding legal entities. Services installed 6/28/19. Pressure tests done on 7/2/19, Bac-T tests done on 7/8/19. Fireline charged on 9/12/19. Mesa Water staff removed two fire hydrants from jobsite on 9/18/19.</p>

## DEVELOPER PROJECT STATUS REPORT

PROJECT STATUS - DEVELOPER PROJECTS			
FILE NO.	PROJECT ADDRESS	PROJECT DESCRIPTION	PROJECT NOTES/STATUS
C0062-19-01	1591 & 1593 Riverside	Two Single Family Homes	Plans received and plan check fees paid on 12/14/18. Final fees paid on 2/6/19. Permit issued on 2/13/19. Precon held on 2/28/19. Services installed on 3/4/19. Waiting for meter installation and flowthru testing to be scheduled.
C0063-19-01	1375 Sunflower	Commercial Building	Plans received and plan check fees paid on 12/14/18. Customer picked up redlines on 12/31/18. Second plan check submitted on 1/11/19, and redlines picked up on 1/29/19. Third plan check submitted on 1/31/19. Final permit fees paid on 6/20/19 and permit issued on 6/25/19.
C0071-19-01	2277 Harbor Boulevard	Commercial Building	Plans received and plan check fees paid on 1/7/19. Customer picked up redlines on 1/25/19. Second plan check submitted on 1/28/19, and redlines picked up on 1/31/19. Final permit fees paid on 5/28/19. Permit issued on 5/30/19.
C0072-19-01	168 & 170 Cabrillo	Two Single Family Homes	Plans received and plan check fees paid on 1/14/19. Customer picked up redlines on 1/24/19. Customer submitted second plan check on 5/9/19. Second plan check submitted on 5/13/19 and redlines picked up on 5/20/19. Final permit fees paid on 9/26/19. Permit issued on 10/3/19.
C0073-19-02	55 Fair Drive	Vanguard University East Annex Science Modular	Plans received and meter replacement fees paid on 3/14/19. First plan check completed on 5/9/19 and redlines mailed on 5/14/19. Second plan check submitted 7/3/19. Precon held on 7/3/19. Servies installed on 8/8/19, Backflow prevention devices tested on 8/20/19.
C0074-19-01	2538 Oxford Lane	Single Family Home	Plans received and plan check fees paid on 11/14/18. Customer picked up redlines on 1/31/19. Second plan check submitted on 2/1/19, and redlines picked up on 2/5/19. Waiting for 3rd plan check submittal. Received fire department approval on 5/31/19.
C0077-19-01	1922 Pomona	Commercial Building	Plans received and plan check fees paid on 1/28/19. Customer picked up redlines on 2/1/19. Second plan check submitted on 2/5/19, and redlines picked up again on 2/12/19. Final fees paid on 2/27/19. Permit issued on 3/11/19. Precon meeting held on 3/19/19. Meter installed 3/28/19.

## DEVELOPER PROJECT STATUS REPORT

PROJECT STATUS - DEVELOPER PROJECTS			
FILE NO.	PROJECT ADDRESS	PROJECT DESCRIPTION	PROJECT NOTES/STATUS
C0079-19-01	1957 Newport Boulevard	Meter Upgrade	Plans received and plan check fees paid on 2/5/19. Customer picked up redlines on 2/27/19. Meeting on 3/5/19 with customer to discuss easement. Second plan check was submitted on 4/23/19 and redlines to be picked up on 5/6/19. Third plan check submitted on 5/16/19. Permit approved on 8/23/19. Precon held on 9/3/19. Shutdown to tie in tee & valve service line placement and pipeline installation completed on 9/11/19.
C0082-19-01	3323 Hyland Avenue	Pipeline relocation	Plans received and plan check fees paid on 2/20/19. Customer picked up redlines on 3/4/19. Second plan check submitted 3/26/19, and redlines picked up on 4/2/19. Second plan check submitted 6/11/19, and redlines picked up on 6/18/19. Final permit fees paid on 7/23/19 and permit issued on 8/6/19. Waiting for Contractor to pick up permit.
C0084-19-01	410 E 17th Street	Commercial Business	Plans received and plan check fees paid on 2/20/19. Customer picked up redlines on 3/4/19. Second plan check submitted on 9/4/19 and redlines picked up on 9/10/19. 3rd Plan check submitted on 9/26/19.
C0085-19-01	3030 Airway Avenue, Suite B	Commercial Business	Plans received and plan check fees paid on 3/5/19. Customer picked up redlines on 3/12/19. Second plan check submitted 04/1/19, and redlines picked up on 4/8/19. Final permit fees paid on 5/2/19 and permit issued on 6/6/19. Precon held on 6/20/19. Backflow device tested 7/27/19. Existing meter downgraded on 7/30/19. Backflow tested on 8/7/19. Flow tests performed by customer service and operations on 9/11/19.
C0086-19-01	285 22nd Street	Residential Care Facility	Plans received and plan check fees paid on 3/11/19. Customer picked up redlines on 3/19/19. Second plan check submitted on 5/9/19. Customer to pick up Second plan check redlines on 5/6/19. Third plan check submitted on 5/14/19 and picked up on 5/30/19. Precon held on 8/30/19. Service connection on 9/3/19. Abandonments completed on 9/6/19. Meter installed on 9/12/19.
C0089-19-01	3160 Airport Way	John Wayne Airport Taxilot	Plans received and plan check fees paid on 4/8/19. 1st Plan Check submitted on 4/9/19. Second plan check submitted 04/19/19 and redlines picked up on 4/25/19. Final permit fees paid on 6/18/19.

## DEVELOPER PROJECT STATUS REPORT

PROJECT STATUS - DEVELOPER PROJECTS			
FILE NO.	PROJECT ADDRESS	PROJECT DESCRIPTION	PROJECT NOTES/STATUS
C0090-19-01	2831 Bristol Street	Parking Lot	Plans received and plan check fees paid on 4/9/19. 1st Plan Check submitted on 4/11/19. Customer picked up redlines on 4/16/19. Second plan check submitted 04/19/19 and redlines picked up on 4/25/19. Final permit fees paid on 5/2/19 and permit issued on 6/6/19. Precon held on 9/5/19. Backflow device tested on 4/25/19.
C0091-19-01	368 Magnolia	Single Family Home	Plans received and meter replacement fees paid on 4/15/19. First plan check submitted on 4/18/19 and redlines picked up on 4/23/19. Final permit fees paid on 5/20/19 and permit issued on 5/20/19. Precon held on 8/8/19. Service laterals installed and approved on 8/27/19.
C0092-19-01	Harbor and Hamilton	29 New Townhomes	Plans received and plan check fees paid on 4/23/19. First plan check submitted 4/23/19 and redlines to be picked up on 5/6/19. Second plan check submitted on 6/11/19 and redlines picked up on 6/18/19.
C0093-19-01	163 Broadway	Single Family Home	Plans received and meter replacement fees paid on 4/24/19. 1st Plan check submitted on 4/24/19 and redlines picked up on 5/6/19. Second plan check submitted on 5/13/19 and redlines picked up on 5/24/19. Final Permit fees paid on 7/3/19 and permit issued on 7/3/19. Precon held on 7/9/19.
C0095-19-01	272 Esther Street	Single Family Home	Plans received and plan check fees paid on 4/30/19. 1st Plan check submitted 4/30/19 and redlines to be picked up on 5/7/19. Second Plan check submitted 6/4/19 and redlines to be picked up on 6/11/19. Final permit fees paid on 8/27/19.
C0096-19-01	333 E. 17th Street, Suite 22	Commercial	Plans received and plan check fees paid on 4/30/19. 1st Plan check submitted 4/23/19 and redlines picked up on 5/9/19. Permit issued 9/6/19. Precon held on 9/12/19.
C0097-19-01	3505 Cadillac, Suite L-3	Commercial	Plans received and plan check fees paid on 4/30/19. 1st Plan check submitted 4/30/19 and redlines to be picked up on 5/9/19. Second plan check submitted on 6/4/19 and redlines picked up on 6/11/19. Final permit fees paid on 8/6/19 and permit picked up on 8/6/19. Precon conducted on 8/13/19. Hot-tapping, service line placement and thrustrblock placement completed on 8/29/19. Chlorination flush, pressure test and Bac-T sample on 9/3/19. Bac-T sample and backfill completed on 9/4/19. Backflow placement and test, and fireline charged on 9/11/19.

## DEVELOPER PROJECT STATUS REPORT

PROJECT STATUS - DEVELOPER PROJECTS			
FILE NO.	PROJECT ADDRESS	PROJECT DESCRIPTION	PROJECT NOTES/STATUS
C0099-19-01	3505 Cadillac, Suite E	Commercial	Plans received and plan check fees paid on 6/3/19. 1st Plan check submitted 6/3/19 and redlines picked up on 6/6/19. 2nd Plan check submitted on 6/10/19 and redlines picked up on 6/13/19. Final permit fees and permit picked up on 8/15/19. Precon conducted on 8/22/19, Bac-T samples taken on 8/27/19. Hot-tapping, service line placement and thrustrblock placement completed on 8/23/19. Backflow test and mainline turned on 9/5/19. Backflow preventers certified on 9/11/19. Fireline charged on 9/30/19.
C0101-19-01	1275 Bristol Avenue	Car Dealership	Plans received and plan check fees paid on 6/11/19. 1st Plan check submitted 6/11/19 and redlines picked up on 6/18/19. 2nd Plan check submitted on 8/13/19 and picked up on 8/20/19. 3rd Plan check submitted 9/3/19 and returned on 9/10/19.
C0102-19-01	3560 Cadillac Avenue	Commercial	Plans received and plan check fees paid on 6/18/19. 1st Plan check submitted 6/18/19 and redlines to be picked up on 7/2/19. 2nd Plan check submitted on 7/9/19 and picked up on 7/16/19. Final permit fees paid and permit issued on 8/6/19.
C0103-19-01	150 Paularino	Commercial	Plans received and plan check fees paid on 6/18/19. 1st Plan check submitted 6/18/19 and redlines to be picked up on 7/3/19. 2nd Plan check submitted on 7/19/19 and picked up on 7/23/19. 3rd Plan check submitted on 8/20/19 and picked up on 8/28/19. 4th Plan check submitted on 9/3/19 and returned on 9/3/19. Permit fees paid on 9/11/19 and permit issued on 9/26/19. Precon held on 9/30/19. Services installed on 10/2/19.
C0104-19-01	413 E. 20th Street	Single Family Home	Plans received and plan check fees paid on 7/1/19. 1st Plan check submitted 7/1/19 and redlines picked up on 7/1/19.
C0105-20-01	3333 Avenue of the Arts	Commercial	Plans received and plan check fees paid on 7/24/19. 1st Plan check submitted 7/26/19 and redlines to be picked up on 7/26/19. 2nd Plan check submitted on 8/30/19 and resubmitted on 9/11/19.
C0106-20-01	224 Flower	Single Family Home	Plans received and plan check fees paid on 7/24/19. 1st Plan check submitted 7/26/19 and redlines picked up on 7/26/19. Second plan check submitted on 9/10/19 and picked up on 9/24/19. Third plan check resubmitted on 10/3/19.

## DEVELOPER PROJECT STATUS REPORT

PROJECT STATUS - DEVELOPER PROJECTS			
FILE NO.	PROJECT ADDRESS	PROJECT DESCRIPTION	PROJECT NOTES/STATUS
C0107-20-01	1835 Newport Blvd, Suite F	Commercial	Plans received and plan check fees paid on 7/15/19. 1st Plan check submitted 7/26/19 and redlines to be picked up on 7/26/19. Second plan check submitted on 7/30/19 and picked up on 8/6/19. Permit approved and final fees paid on 8/15/19. Precon held on 9/5/19 and again on 9/20/19. New 6-inch valve installed to assist with shutdowns on 9/30/19. Service line placement for 10/3/19. Pressure test completed on 10/4/19.
C0108-20-01	130 Magnolia Street	Single Family Home	Plans received and plan check fees paid on 7/30/19. 1st Plan check submitted 7/30/19 and redlines picked up on 8/6/19. Second plan check submitted on 9/18/19, and redlines picked up on 9/24/19. Permit approved and final fees paid on 9/30/19. Precon held on 10/2/19. Meter upgraded on 10/8/19. Flowthru system tested on 10/8/19.
C0110-20-01	861 Governor Street	Single Family Home	Plans received and plan check fees paid on 7/15/19. 1st Plan check submitted 7/26/19 and redlines picked up on 7/26/19.
C0112-20-01	1626 Ohms Way	Commercial	Plans received and plan check fees paid on 7/16/19. 1st Plan check submitted 7/29/19 and redlines picked up on 7/29/19. 2nd Plan check submitted 8/7/19 and picked up on 8/20/19. 3rd Plan check submitted on 8/22/19 and picked up on 8/29/19.
C0113-20-01	1588 South Coast Drive (Vans Headquarters)	Commercial	Plans received and plan check fees paid on 8/13/19. 1st Plan check submitted 8/13/19 and redlines picked up on 8/20/19. Second plan check submitted 9/12/19 and picked up on 10/1/19.
C0114-20-01	279 Flower Street	Single Family Home	Plans received and plan check fees paid on 8/20/19. 1st Plan check submitted 8/27/19 and redlines picked up on 8/27/19.
C0115-20-01	2179 Miner Street	Single Family Home	Plans received and plan check fees paid on 8/20/19. 1st Plan check submitted 8/27/19 and redlines picked up on 8/27/19.



## MESA WATER AND OTHER AGENCY PROJECTS STATUS REPORT

October 2019

**Project Title:** OC-44 Replacement and Rehabilitation Evaluation and Cathodic Protection Study

**File No.:** M 2034

**Description:** Evaluate potential repair and replacement options

**Status:** The Habitat Mitigation and Monitoring Plan (HMMP) has been updated by Michael Baker (former RBF) to reflect the USACE's process and submitted to Mesa Water for review on 1/8/16. Once the HMMP is revised and approved (1/19/16) it will be forwarded to all agencies, including the Coastal Commission. Draft 1602 Streambed Permit obtained on 12/18/15. Final 1602 Streambed Permit pending CDFW will be issued while HMMP is accepted. U.S. Army Corps of Engineers' 404 permit received on 2/10/16. Revised HMMP sent to CCC for review and approval. Project is pending CCC's approval at an upcoming hearing. On 2/29/16, a meeting with Fletcher Jones Motorcars, City of Newport Beach, MBI (former RBF), and City of Huntington Beach was held to discuss issues associated with proposed construction activities. Traffic Plan prepared and submitted to the City of Newport Beach for approval on 6/29/16. Per request of CCC a dewatering plan was prepared and submitted for approval. Mesa Water staff, MBI and CCC met on 10/6/16 and discussed mitigation conditions. Project approved at CCC Public Hearing on 12/7/16. MBI is working on finalizing the HMMP and construction plans and will submit them to CCC. Staff met with MBI on 5/1/17 and discussed comments after reviewing the draft final HMMP. New proposed mitigation criteria received from CCC on 7/5/17 reducing mitigation requirements from 1.6 acres to 0.66 acres. Coastal Development Permit for Construction is anticipated in December, 2017. The project re-start meeting was held on 9/7/17. On 10/30/17 met with City of Newport Beach and City of HB to discuss permit requirements and project access. Met w/Fletcher Jones, Skender Construction, City of HB, MBI to discuss access to the site and scheduling on November 21, 2017. Reviewing the 100% Design Plans & Specs (received on 11/28/17) along with the Pipeline Design Schedule, Construction Monitoring Treatment Plan (CMTP), and proposal for Natural Resources/Regulatory Services during construction activities. Bid solicitation is scheduled for late January 2018. Project sent out to bid on January 30, 2018. Pre-bid meeting held on 2/15/18. Construction bid solicitation was cancelled due to ongoing coordination issues for the final Coastal Development permit. Project was deferred to FY20. On 8/1/18, Orange County Public Works issued a one-year extension to the previously issued Encroachment Permit. The Caltrans Encroachment Permit extension application is under review as of 8/13/18. The CCC extended the permit a year without hearing. MBI moved forward with the amendment to reduce mitigation. The updated information was forwarded by MBI to CCC in the week of August 6, 2018 and November 2, 2018. Staff held a stakeholder coordination meeting on 1/3/2019. Request for Bids sent out to contractors on February 6, 2019. Six bids received on 3/6/19. E&O Committee recommended award of the contract to lowest bidder (E.J. Meyer Company) on 3/19/19. Kick-off meeting held on 4/25/2019. Staff is working on reviewing submittals. Met with SARWQB on 5/24/19 and discussed water discharge permit requirements w/Susan Beeson. On 5/30/19 met with OCSD and went over requirements for the Special

## MESA WATER AND OTHER AGENCY PROJECTS STATUS REPORT

October 2019

Purpose Discharge Permit (SPDP). Held Project Progress meeting on 6/6/19 and coordination meeting with Metropolitan Water District on 6/20/19. Held Permit Status Meeting on 7/11/2019, Traffic Coordination Meeting with Fletcher Jones Mercedes Dealership on 7/23/2019 and Project Progress Meeting on 7/23/2019. Submitted Application Package to OCSD for SPDP on 7/31/2019. Received Special Purpose Discharge Permit from OCSD on September 1, 2019. Coordination meeting with Fletcher Jones and Project Progress Meeting was held on 9/11/19. Contractor mobilized on 9/15/19 and started dewatering efforts. Project in Progress. (10/3/19)

**Project Title:** Pipeline Testing Program

**File No.:** MC 2141

**Description:** Implement Resolution No. 1442 Replacement of Assets to annually perform non-destructive testing of 1% of the distribution system, and destructive testing of segments that are shown to have less than 70% of original wall thickness by non-destructive testing.

**Status:** Three miles of AC pipe constructed in 1956 were selected for non-destructive wall thickness measurement, which occurred during the week of January 14, 2019. The report was received on February 8, 2019. Five AC pipe samples are planned to be collected and sent for wall thickness measurements as part of routine valve replacements in April 2019. Samples were sent to the testing lab in May 2019, and the wall thickness measurement report was received on June 24, 2019. With more data collected from AC pipe samples, a proposed update the Res. 1442 Replacement of Assets was presented to the E&O Committee in September 2019. Staff is preparing for implementation of the updated Replacement of Assets policy. (10/7/19)

**Project Title:** Mesa Water Administration Building Improvements & HVAC Replacement/Operation Building Repair Projects

**File No.:** MC 2171

**Description:** Evaluate the existing HVAC system, provide recommendations for improved efficiency and operations of the system, provide design, construction management, and construction.

**Status:** On 2/11/19 Snyder completed painting, carpeting and concrete floor polishing, installation of interior portion of the HVAC system, ceiling tiles and baseboards, rehabilitation of the upstairs and downstairs restrooms, overall cleaning. Also the furniture in supervisors and water quality office were reassembled. The contractor continued working on the roof of the Ops Building on installation of ducts and preparing for the upcoming rain. Starting from February 15 the contractor worked on the HVAC replacement on the second floor of the Administration building and EOC. The work included demolishing of old ducted HVAC piping, blocking for HVAC units, installation of HVAC units, installation of refrigerant and condensate piping, electrical work, painting, installation of the ceiling and carpet tiles, new water fountains and partial demolition of roofing for HVAC platform installation. The work on the second floor was completed on 4/24/2019 and the contractor started working on the first floor on 4/30/2019. The work included installation of HVAC units, installation of refrigerant and condensate piping,

## MESA WATER AND OTHER AGENCY PROJECTS STATUS REPORT

October 2019

electrical work, and plumbing. Work on the first floor of the Administration Building including installation of skylight completed on 6/8/19. Project was completed on 9/20/19. The "Punch List" items will be addressed after 10/15/19. (10/3/19)

**Project Title:** Chandler & Croddy Wells and Pipeline Project

**File No.:** M18-113

**Description:** Design, documentation, and permitting for two new wells located on Chandler Avenue and Croddy Way in the City of Santa Ana and the distribution pipeline connecting the wells to Mesa Water's supply system.

**Status:** Tetra Tech has been contracted to complete the design, documentation, and permitting for the Chandler and Croddy Wells and Pipeline Project. Initial data request sent to Tetra Tech on September 7, 2017. Met with Division of Drinking Water regarding well locations on September 20, 2017. Preliminary hydrological evaluation received on September 29, 2017. Board approved demolition of existing structures and dedicated well facility with option to evaluate long-term lease potential as market conditions dictate at both sites at November 2017 E&O. Butier Engineering has been contracted to provide Construction Management Services. Preliminary Design Report (PDR) for the distribution pipeline was reviewed and returned on March 6, 2018. Well site layouts were presented to the Board in May. DDW waiver for 50-foot control zone is currently being drafted. The revised PDR for the pipeline and the well sites was received in June 2018. A workshop to discuss review comments was held on August 14, 2018. 50% design for the Croddy Pipeline was received and the design review workshop occurred on November 26, 2018. 50% design for the wells is scheduled for submittal in February 2019. The draft CEQA Mitigated Negative Declaration was received on January 22, 2019, and filed for 30-day public comment on February 20, 2019 and completed on March 22, 2019. Four agencies submitted minor comments. A public meeting to adopt the Mitigated Negative Declaration has been noticed for the April 11, 2019 Board of Directors meeting. The revised Preliminary Design Report for the Chandler and Croddy Wells was received on March 5, 2019. 50% design documents for the existing building demolitions and well drilling were received on April 16, 2019. 50% design documents for well equipping were received on September 9, 2019 and are being reviewed by staff. The design team met on October 7, 2019, to review design options for the Croddy Pipeline. 90% design documents for the Croddy Pipeline are expected in October 2019. (10/7/19).

**Project Title:** Meter Technology Evaluation

**File No.:** MC 2248

**Description:** The lifespan of a water meter is approximately 15 years. As a meter ages, the accuracy drops off due to wear. In preparation for its annual water meter replacement, staff has been reviewing water meter technology determining what water meter and reading solutions would be the best fit for Mesa Water's aging register technology. With today's technology, there are several types of meters and meter reading solutions available. The most common are as follows: Fixed Network, Automatic Meter Reading (AMR) System, Handheld or Touch Technology, and Advanced Metering Analytics - Cellular Endpoint.

## MESA WATER AND OTHER AGENCY PROJECTS STATUS REPORT

October 2019

**Status:** Mesa Water prepared a Technical Memo with information of the existing aging metering technology in comparison with proposed new meter reading solutions. The Technical memo was presented to the April E&O Committee and approved by the Board at the May 2019 Board meeting. Recommendations approved by the Board for early implementation include ensuring competitive pricing from the standardized meter supplier, making cellular endpoint meters available to customers who wish to have access to real-time water use data, and working with the meter reading software vendor to configure a software upgrade. Staff has compiled the total installed cost of the cellular endpoint meters and presented an implementation plan to the Engineering and Operations Committee on August 20, 2019. Staff also negotiated a contract with National Meter and Automation for preferred customer pricing and limiting annual price escalation, and presented the contract to the Engineering and Operations Committee on August 20, 2019. Staff is working with Badger Meter and Cogsdale to add cellular endpoints to large customer meters to automate meter reading and billing. (10/7/2019)

**Project Title:** Reservoirs 1 & 2 Chemical Systems Design

**File No.:** M18-117

**Description:** Improve disinfection and mixing in both reservoirs to improve water quality and minimize nitrification.

**Status:** Final Design Contract awarded to Hazen & Sawyer on February 14, 2018. 50% design report received on July 17, 2018. Design review workshop took place in September 2018. A site visit to Laguna Beach County's El Morro reservoirs occurred on November 8, 2018, to evaluate the Vortex mixing system. Staff met with the designer on December 5, 2018, to incorporate design-for-reliability and design-for-maintainability principals into the mixing system design.. The consultant provided a Technical Memo summarizing the options for maintainability and reliability of the Vortex mixer system on April 4, 2019. The 90% design deliverable was received on June 4, 2019, and is being reviewed by staff. Per the E&O Committee's request, the Preliminary Design Report describing the basis of this project is included in the October E&O Committee package. (10/7/2019)

# Water Quality Call Report

## September 2019

**Date:** 9/3/2019  
**Source:** Phone/Visit  
**Address:** 973 Junipero  
**Description:** Customer replaced a toilet valve and noticed that his toilet tank walls have brown stains on them.

**Outcome:** Water collected from the outside hose bib was clear with no odor and total chlorine residual and pH were within normal range. It's likely that the brown stains are from microorganisms growing due to loss of chlorine residual as water sits in the toilet tank for extended periods of time.

**Date:** 9/10/2019  
**Source:** Phone  
**Address:** 202 Albert  
**Description:** Landlord called stating that her tenant has noticed that the drain smells when they use hot water.

**Outcome:** Explained to the landlord how to determine if the odor is coming from the water or the drain/p-trap. Customer said that a plumber had told her the same and she was satisfied. She also inquired about the water quality report, so information was provided.

**Date:** 9/12/2019  
**Source:** Phone  
**Address:** 1617 Coriander #A  
**Description:** Customer recently moved into the apartment and noticed that the water has a strong chlorine odor in the shower, dishwasher, etc.

**Outcome:** Spoke with customer and set up an appointment but customer was not able to keep the appointment. Several calls and messages have been left to reschedule the appointment but customer has not replied.

**Date:** 9/16/2019  
**Source:** Phone/Visit  
**Address:** 1903 Federal  
**Description:** Customer noticed sewage odor in the water for a few days and would like a site visit.

**Outcome:** Water collected from the front hose bib was clear, had no odor and pH and chlorine residual were within normal range. Also collected a water sample from the tub and the water was also clear with no odor and pH and total chlorine were within normal range. Explained to customer about the possibility of the drain/p-trap off gassing. Customer agreed the water had no odor and she will flush the drains with hot water.

**Date:** 9/24/2019  
**Source:** E-mail  
**Address:** 3202 Michigan Avenue  
**Description:** Customer has noticed water becoming harder in the last couple of months.

**Outcome:** Customer did not provide a phone number, so an e-mail was sent back to the customer letting him know that Mesa Water operates several wells with varying levels of hardness. Depending on the wells running, the levels of hardness can change. Customer did not respond.



## COMMITTEE POLICY & RESOLUTION REVIEW

### ENGINEERING and OPERATIONS COMMITTEE

#### Policy Assignments for 2019

Policy Name	Resolution No.	Date Adopted	Revision Schedule	Last Reviewed
Replacement of Assets Including Pipeline and Well Rehabilitation	1525	10/10/19	Review and update every 5 years	10/10/19
Rules and Regulations for Water Service	1514	07/12/18	Review and update as needed  *Scheduled for the 11/25/19 Finance Committee Meeting	07/12/18
Standard Specifications and Standard Drawings		05/03/18	Review and update as needed	05/03/18
Urban Water Management Plan	1477	06/09/16	Review and update as required every 5 years	06/09/16

Water Operations Status Report  
July 1, 2019 - September 30, 2019

Operations Department Status Report	Wk Unit	Plan Days	Act Days	Plan Qty	Act Qty	Plan Cost	Actual Cost
<b>01 - HYDRANTS</b>							
WD-0101 - HYDRANT MAINTENANCE	HYDRANTS	44	34	880	673	\$17,451	\$14,091
WD-0102 - HYDRANT PAINTING	HYDRANTS	4	14	110	402	\$1,304	\$5,000
WD-0103 - HYDRANT REPAIR	HYDRANTS	13	12	15	18	\$4,279	\$8,863
<b>Program 01 TOTAL</b>		61	60			\$23,034	\$27,954
<b>02 - VALVES</b>							
WD-0201 - DISTRIBUTION VALVE MAINTENANCE	VALVES	31	18	625	371	\$13,540	\$7,885
WD-0202 - NIGHT VALVE MAINTENANCE	VALVES	6	0	82	0	\$2,786	\$0
<b>Program 02 TOTAL</b>		37	18			\$16,326	\$7,885
<b>03 - METERS</b>							
WD-0305 - ANGLE STOP/BALL VALVE REPLACE	REPLACE	7	3	14	6	\$4,282	\$1,050
<b>Program 03 TOTAL</b>		7	3			\$4,282	\$1,050
<b>04 - MAIN LINES</b>							
WD-0401 - MAIN LINE REPAIR	REPAIRS	31	17	5	3	\$15,719	\$8,157
WD-0402 - AIR VAC MAINTENANCE/REPAIR	REPAIRS	7	3	41	4	\$2,548	\$1,318
<b>Program 04 TOTAL</b>		38	20			\$18,267	\$9,475
<b>05 - SERVICE LINES</b>							
WD-0501 - SERVICE LINE REPAIR	REPAIRS	15	25	5	11	\$6,226	\$11,326
<b>Program 05 TOTAL</b>		15	25			\$6,226	\$11,326
<b>06 - CAPITAL</b>							
CAP AV - CAPITAL AIR VACUUM REPLACE	AIR VACS	0	5	0	1	\$0	\$1,808
CAP BI - CAPITAL BYPASS & METER INSTALL	REPLACE	0	0	0	0	\$0	\$0
CAP FH - CAPITAL HYDRANT UPGRADE	HYDRANTS	62	26	9	3	\$47,719	\$19,349
CAP MV - CAPITAL MAINLINE VALVE REPLACE	VALVES	51	36	9	4	\$34,596	\$18,734
CAP SL - CAPITAL SERVICE LINE REPLACE	SERVICES	10	14	3	4	\$5,337	\$6,960
CAP SS - CAPITAL SAMPLE STATION REPLACE	STATIONS	0	1	0	1	\$0	\$184
<b>Program 06 TOTAL</b>		123	82			\$87,652	\$47,035
<b>VACANT POSITIONS</b>	2		139				
<b>TOTAL</b>						\$155,787	\$104,725





*Dedicated to  
Satisfying our Community's  
Water Needs*

## MEMORANDUM

TO: Engineering and Operations Committee  
FROM: Phil Lauri, P.E., Assistant General Manager  
DATE: October 15, 2019  
SUBJECT: Water Supply Assessment for the One Metro West Project

---

### RECOMMENDATION

Approve the Water Supply Assessment for the proposed One Metro West Project.

### STRATEGIC PLAN

Goal #1: Provide a safe, abundant, and reliable water supply.  
Goal #2: Practice perpetual infrastructure renewal and improvement.  
Goal #3: Be financially responsible and transparent.  
Goal #6: Provide outstanding customer service.

### PRIOR BOARD ACTION/DISCUSSION

None.

### BACKGROUND

The City of Costa Mesa (City) is currently in the process of preparing an Environmental Impact Report (EIR) for the proposed One Metro West Project (Project). On July 11, 2019, per the requirements of California Senate Bill (SB) 610, the City formally requested preparation of the Water Supply Assessment (WSA) by Mesa Water District (Mesa Water®).

The purpose of the WSA is to satisfy the requirements of Water Code Section 10910 et seq. (SB 610 (2001)) and Government Code Section 66473.7 (SB 221 (2001)) to verify that adequate water supplies are or will be available to meet the water demand associated with the proposed development. While recognizing that it is not possible to guarantee a permanent water supply for all users in California in the amounts requested, SB 610 requires that the WSA, based on specific criteria, be prepared to document the sufficiency of available water supply for Mesa Water and the Proposed project. WSA's are typically prepared for specific development projects.

#### **Project Location**

The 15.75-acre Project site is located at 1683 Sunflower Avenue, Costa Mesa, 92626. The site is bounded by Sunflower Avenue to the north, industrial and office uses to the west, I-405 Freeway to the south, and South Coast Collection (SOCO) retail center to the east. The Project site is currently occupied by Sakura Paper factory, Robinson Pharmaceuticals, and a bakery sub-tenant.

#### **Project Summary**

The proposed Project is a mixed-use development and consists of residential, specialty retail, creative office, and recreational uses. The Project proposes to include up to 1,057 multi-family units, with 25,000 square feet of commercial creative office, 6,000 square feet of specialty retail, 1.7-acres of open space, and 1,750 parking spaces integrated into the residential buildings. All existing buildings, structures, parking areas, drive aisles, and hardscape/landscape improvements are proposed to be demolished.



The proposed development includes three multi-family residential structures with a maximum building height of seven stories; one stand-alone office building up to four stories in height; tenant-serving commercial retail space integrated into one of the residential structures; open space; landscaping; streetscape improvements; and a Class-I bike trail system on Sunflower Avenue providing access to the Santa Ana River Trail.

The Project's construction timeline is six years and would be constructed all at one time. Construction of the proposed Project is anticipated to commence in 2021 and be completed by 2027.

## DISCUSSION

In August 2019, Mesa Water engaged Michael Baker International, Inc. (MBI) to prepare a WSA for the proposed One Metro West Project. On September 2, 2019, Mesa Water received payment to perform the WSA from the Project Applicant. The WSA identifies water supply and reliability within the Mesa Water Distribution System, now and into the future, and makes a determination regarding water supply sufficiency for the Project. The WSA includes a discussion of the relevant legislation requiring the WSA, an overview of the proposed Project, analysis of water demands for Mesa Water's existing service area including the Project over a 20+ year planning period, and an analysis of the supply sufficiency during normal, single-dry, and multiple dry years over the planning period.

The WSA used Mesa Water's 2014 Master Plan Update, the 2015 Urban Water Master Plan, and recent production facility metering data as the basis to develop the WSA. The WSA analysis demonstrates that Mesa Water's average annual demand is approximately 16,065 acre-feet per year (AFY). The One Metro West Development demand is estimated to be 203 AFY. When considering Mesa Water's total available groundwater pumping capacity (28,973 AFY) and imported water back-up supply (69,500 AFY), Mesa Water has more than sufficient supply to accommodate the One Metro West Development and others like it into the future. It should be noted that while the 2014 Master Plan Update and 2015 Urban Water Master Plan were used as foundational documents for the WSA, the actual existing demands are significantly lower than those forecasted in the aforementioned documents largely due to conservation efforts during the 2015-2016 drought.

While Mesa Water has seen an extensive amount of in-fill development over the past few years, there has not been an impact to the overall available supplies. Even with the additional in-fill development and associated additional demand, Mesa Water's overall demands have decreased by approximately 9% since 2015 due to state-wide drought conservation mandates. Mesa Water continues to see fairly stable or decreasing demands (e.g., decreased demand of 6.6% from Fiscal Year (FY) 2018 to FY 2019) over the past few years in spite of additional development. This trend indicates that demand hardening – conservation practices that become part of the mainstream water usage behavior over the long-term – is occurring within the District's service area and is estimated to continue into the future.

Mesa Water's 100% local groundwater reliability provides more than sufficient supplies for existing and future demands analyzed in the WSA and supporting referenced water planning reports and studies. Additionally, Mesa Water is a member Agency of the Municipal Water District of Orange



County and has access to an extensive supply of imported water as a back-up source. Thus, the information contained within the WSA confirms that sufficient water supplies exist within Mesa Water's service area and adjoining region now and into the future.

Staff recommends that the Board approve the Water Supply Assessment for the proposed One Metro West Project.

#### FINANCIAL IMPACT

None.

#### ATTACHMENTS

Attachment A: Water Supply Assessment for Mesa Water District: One Metro West Project



# California Senate Bill 610 Water Supply Assessment

for

# Mesa Water District One Metro West Project

Prepared for  
Mesa Water District

by:

**Michael Baker**  
INTERNATIONAL



**October 2019**

This page intentionally left blank

## Table of Contents

ACRONYMS AND ABBREVIATIONS.....	iv
EXECUTIVE SUMMARY .....	1
Water Supply.....	2
Water Demand.....	2
Demand and Supply Projections.....	2
Conclusion.....	2
1.0 INTRODUCTION.....	3
2.0 LEGISLATION .....	5
2.1 SB 610 – Water Supply Planning.....	5
2.2 SB X7-7 and EO B-37-16 and EO B-40-17.....	6
3.0 ONE METRO WEST PROJECT.....	8
3.1 Project Description .....	8
3.2 Project Water Demands.....	8
4.0 MESA WATER DISTRICT WATER DEMAND.....	11
4.1 Overview .....	11
4.2 Factors Affecting Demand .....	11
4.2.1 Climate Characteristics .....	12
4.2.2 Demographics .....	12
4.2.3 Land Use.....	13
4.3 Water Use by Customer Type.....	13
4.3.1 Overview .....	13
4.3.2 Non-Residential.....	14
4.3.3 Sales to Other Agencies .....	14
4.3.4 Non-Residential.....	14
4.4 Demand Projections.....	15
4.4.1 Demand Projection Methodology .....	15
4.4.2 Agency Refinement.....	16
4.4.3 Projections throughout 2040.....	16
4.4.4 Total Water Demand Projections .....	17
4.5 SB X7-7 Requirements .....	17

4.5.1	2015 and 2020 Targets.....	18
5.0	WATER SOURCES AND SUPPLY RELIABILITY .....	19
5.1	Overview .....	19
5.2	Imported Water .....	19
5.3	Groundwater.....	20
5.3.1	Basin Characteristics .....	21
5.3.2	Basin Production Percentage.....	23
5.3.2.1	2015 OCWD Groundwater Management Plan .....	24
5.3.2.2	OCWD Engineer’s Report.....	25
5.3.3	Groundwater Historical Extraction .....	26
5.4	Summary of Existing and Planned Sources of Water .....	26
5.5	Supply Reliability.....	26
5.5.1	Overview .....	26
5.5.2	Factors Impacting Reliability.....	27
5.5.2.1	Legal.....	27
5.5.2.2	Water Quality .....	27
5.5.2.2.1	Imported water .....	27
5.5.2.2.2	Groundwater.....	28
5.5.2.3	Climate Change.....	30
5.5.3	Normal-Year Reliability Comparison.....	30
5.5.4	Single-Dry Year Reliability Comparison.....	31
5.5.5	Multiple-Dry Year Reliability Comparison .....	31
5.6	Supply and Demand Assessment.....	32
5.7	Water Shortage Contingency Plan.....	33
5.7.1	Shortage Actions.....	33
5.7.1.1	MWDOC Water Supply Allocation Plan .....	33
5.7.2	Three-Year Minimum Water Supply .....	34
5.7.3	Catastrophic Supply Interruption .....	35
5.7.3.1	Metropolitan.....	35
5.7.3.2	Mesa Water District Water Shortage Emergency Response.....	35
5.7.4	Prohibitions, Penalties and Consumption Reduction Method .....	36
5.7.4.1	Mesa Water District Water Shortage Emergency Response.....	36

5.7.4.2 Penalties ..... 39

5.7.4.3 Consumption Reduction Methods ..... 40

5.7.5 Reduction Measuring Mechanism ..... 40

6.0 CONCLUSION..... 41

List of Tables

Table 3-1: Existing and Proposed Development..... 8

Table 3-2: Water Demand Factors <sup>[1]</sup> ..... 9

Table 3-3: Existing Water Demands <sup>[1]</sup> ..... 9

Table 3-4: Project Water Demands <sup>[1]</sup> ..... 10

Table 3-5: Net Increase in Demand ..... 10

Table 4-1: Population - Current and Projected..... 12

Table 4-2: Demands for Potable Water – Actual (AF)..... 14

Table 4-3: Water Loss Audit Summary ..... 15

Table 4-4: Projected Future Development Demand..... 16

Table 4-5: Demands for Potable Water- Projected (AF)..... 16

Table 4-6: Total Water Demands (AF) ..... 17

Table 4-7: Baselines and Targets Summary ..... 18

Table 4-8: 2015 Compliance ..... 18

Table 5-1: Imported Water Capacity ..... 20

Table 5-2: Clear Water Wells Capacity ..... 24

Table 5-3: Amber Wells and MWRf Capacity ..... 24

Table 5-4: OC Groundwater Basin Summary ..... 25

Table 5-5: Groundwater Volume Pumped (AF) ..... 26

Table 5-6: Water Supplies, Actual (AF) ..... 26

Table 5-7: Water Supplies, Projected (AF)..... 26

Table 5-8: Basis of Water Year Data ..... 32

Table 5-9: Normal Year Supply and Demand Comparison (AF)..... 32

Table 5-10: Dry Year Supply and Demand Comparison (AF) ..... 32

Table 5-11: Multiple Dry Years Supply and Demand Comparison (AF) ..... 33

Table 5-12: Stages of Water Shortage Contingency Plan ..... 34

Table 5-13: Minimum Supply 2016-2018 (AF)..... 35

Table 5-14: Restrictions and Prohibitions on End Uses ..... 36

Table 5-15: Stages of Water Shortage Contingency Plan - Consumption Reduction Methods ... 40

List of Figures

Figure 5-1: Water Supply Sources in Mesa Water® (AF) ..... 19

Figure 5-2: Map of the Orange County Groundwater Basin and Its Major Aquifer Systems..... 22



## ACRONYMS AND ABBREVIATIONS

ACT .....	Urban Water Management Planning Act of 1983
AF .....	Acre Feet
AFY .....	Acre Feet per Year
AWPF.....	Advanced Water Purification Facilities
CCF .....	Hundred Cubic Feet
CDD .....	City Distribution Division
CVP .....	Central Valley Project
CPTP .....	Coastal Pumping Transfer Program
DSOD .....	Department of Safety of Dams
DU .....	Dwelling Unit
DWR .....	Department of Water Resources
EIR .....	Environmental Impact Report (see PEIR)
EO .....	Executive Order
EOC.....	Emergency Operations Plan
ERRP .....	Emergency Response and Recovery Plan
FY.....	Fiscal Year
GP .....	General Plan
GPCPD .....	Gallons Per Capita Per Day
gpd .....	Gallons Per Day
gpm .....	Gallons Per Minute
IRP .....	Infrastructure Reliability Project
ISA .....	Interim Supply Allocation
ISL .....	Interim Supply Limitation
ITR .....	Industrial to Residential
KSF.....	Thousand Square Feet
MAF .....	Million Acre Feet
Max .....	Maximum
MCL .....	Maximum Contaminant Level
MGD .....	Million Gallons per Day
mg/L .....	Milligrams Per Liter
MHI.....	Median Household Income
Min .....	Minimum
MWDOC .....	Municipal Water District of Orange County
PEIR .....	Program Environmental Impact Report
RHNA .....	Regional Housing Needs Assessment
RWQCB.....	Regional Water Quality Control Board
RWS.....	Regional Water System
SB.....	Senate Bill
SB X7-7 .....	Water Conservation Act of 2009
SF.....	Square Feet

SWP .....	State Water Project
SWRCB .....	State Water Resources Control Board
USBR .....	U.S. Bureau of Reclamation
UWMP .....	Urban Water Management Plan
WCIP .....	Water Conservation Implementation Plan
WPCP .....	Water Pollution Control Plant
WSA .....	Water Supply Assessment or Water Supply Agreement
WSIP .....	Water System Improvement Program
WS&TD .....	Water Supply and Treatment Division
WUMP .....	Water Utility Master Plan
WWTP .....	Waste Water Treatment Plant

## EXECUTIVE SUMMARY

The purpose of the “Water Supply Assessment Report” is to satisfy the requirements under Senate Bill 610 (SB 610), Water Code Section 10910 et seq., and Senate Bill 221 (SB 221), Government Code Section 66473.7 that adequate water supplies are or will be available to meet the water demand associated with the proposed development. While recognizing that it is not possible to guarantee a permanent water supply for all users in California in the amounts requested, SB 610 requires that a water supply assessment (WSA), based on specific criteria, be prepared to document the sufficiency of available water supply for the Mesa Water District (Mesa Water®) and the proposed project. WSA’s are typically prepared for specific development projects. In this particular case, One Metro West Project (Project). The WSA identifies water supply and reliability within the Mesa Water® Distribution System, now and into the future, and makes a determination regarding water supply sufficiency for the Project. **The WSA does not, nor is it intended to, identify infrastructure needs for service distribution for the proposed projects.**

Mesa Water District created 2015 Urban Water Management Plan (2015 UQMP) to determine the existing and projected water demand supply. The 2015 UWMP states that the local groundwater wells Mesa Water® utilizes sufficiently supply the existing and projected water demands. The 2015 UWMP did not consider the proposed One Metro West Development Project. One Metro West is a 16.2-acre mixed-use community including residential, commercial and office spaces. The existing area is occupied by a dietary supplement manufacturer, a commercial decoration warehouse, and a frozen bakery product and supplies manufacturer, the One Metro West Project will replace the existing building. This WSA identifies water supply and reliability to Mesa Water®, now and into the future, and makes a determination regarding water supply sufficiency for the Project. The WSA does not, nor is it intended to, identify infrastructure needs for service distribution for the proposed projects.

Preparation of a WSA is considered at a point in time when known future projects are evaluated and accounted for in future water demands. It is also understood that new and innovative programs and projects in conceptual planning are yet to be designed. Therefore, WSAs are a part of the ongoing planning efforts of Mesa Water® to optimize its water resources program.

The WSA includes a discussion of the relevant legislation requiring the WSA, an overview of the proposed Project, analysis of water demands for Mesa Water®’s existing service area including the Project over a 20+ year planning period, and an analysis of reliability of Mesa Water®’s water supplies. This WSA includes discussion of the potential impacts that each agency that supplies water to the region has on Mesa Water® and concludes with a sufficiency analysis of water supply during normal, single-dry, and multiple dry years over a 20-year planning period.

### Water Supply

Mesa Water District relies on District produced local groundwater from wells and imported water from Metropolitan Water District (MWD). However, Mesa Water® maintains 100 percent reliability on groundwater pumping whenever possible.

- Mesa Water District has groundwater supplied by 7 wells. Five active wells pump “clear” groundwater directly into the distribution system, following disinfection with chloramines. The other two wells pump amber colored groundwater from a deeper aquifer and is treated at the Mesa Water Reliability Facility (MWRF) before distribution. The groundwater wells are a primary source of water to Mesa Water®.
- Mesa Water District has three (3) metered water connections with MWDOC (OC-44, OC-14, and CM-2).

### Water Demand

In FY 2018 Mesa Water® was projected to produce 17,314 AF and actually produced 17,202 AF. In FY 2019 Mesa Water® was projected to produce 17,660 AF and actually produced 16,065 AF, an approximate 9 percent decrease from the projected amount. The development of the One Metro West Project results in a net increase of 203 AFY to the Mesa Water® distribution system.

Mesa Water® has projected that by the year 2040 the total system demand will be 20,809 AFY. Combine this projection with the Proposed Development Project (203 AFY) and the total water demand is anticipated to increase to 21,012 AFY by 2040 under normal water year conditions (drought years would see reduced water demands as a result of conservation measures).

### Demand and Supply Projections

Mesa Water District has a total groundwater well production capacity of 28,937 AFY and will meet its future water demands, including the demands for the Proposed Project, from existing supply sources. Mesa Water® will maintain 100 percent reliability on groundwater pumping, but if needed, imported water is an option. Analysis of water demand and supply projections for Mesa Water® demonstrate that Mesa Water® has water supply contracts with MWDOC that are sufficient to meet the Project’s increased water demand through the year 2040.

This WSA demonstrates that possible reductions in imported water deliveries due to drought conditions do not prevent Mesa Water® from satisfying its anticipated demands.

### Conclusion

The information included in this WSA identifies a sufficient program of water supply for Mesa Water®, now and into the future, including a sufficient water supply for One Metro West.

## 1.0 INTRODUCTION

The purpose of the Water Supply Assessment (WSA) is to satisfy the requirements under Senate Bill 610 (SB 610), Water Code Section 10910 et seq., and Senate Bill 221 (SB 221), Government Code Section 66473.7 that adequate water supplies are or will be available to meet the water demand associated with the proposed One Metro West Development (Project). SB 610 focuses on the content of a water supply agency's Urban Water Management Plan (UWMP). It also stipulates that, when an environmental impact report (EIR) is required in connection with a project, the appropriate water supply agency must provide an assessment of whether its total project water supplies will meet the projected water demand associated with the Proposed Project. SB 610 applies to a proposed residential development of more than 500 dwelling units, or large commercial, industrial, or mixed-use development. SB 221 requires water supply verification when a tentative map, parcel map, or development agreement for a project is submitted to a land use agency for approval. SB 221 applies to proposed residential development of more than 500 dwelling units with some exceptions. The need for an assessment or verification is determined by the lead agency for the project.

The WSA identifies water supply and reliability to the Mesa Water® Distribution System, now and into the future, and makes a determination regarding water supply sufficiency for the Project. **The WSA does not, nor is it intended to, identify infrastructure needs for service distribution for the proposed project.**

Michael Baker is the lead Engineer for the preparation of an EIR pursuant to the California Environmental Quality Act (CEQA), Public Resources Code Section 21000, et seq. for the One Metro West Development. The proposed project is located in the north-western portion of the City of Costa Mesa, adjacent to I-405 and is approximately 1,000 feet from the Santa Ana River, approximately 5 miles from the Santa Ana River's outfall into the Pacific Ocean. The existing site is a 15.60-acre industrial area which will be demolished and replaced with the proposed One Metro West Development. The new development will consist of three residential apartment buildings comprised of 1,057 dwelling units, and 6,000 square feet of specialty retail. A fourth building will house 25,000 square feet of commercial creative office space.

The preparation of the EIR and the proposed 1,057 dwelling units stipulate that a Water Supply Assessment should be prepared for the development.

The WSA is prepared using the most recent Urban Water Management Plan (UWMP), the most recent Water Master Plan (WMP), and additional information provided by Mesa Water District and the Developer. These documents and information serve as the basis of data and includes a discussion of the Senate Bill 610 legislation, an overview of the proposed land use changes identified in the Project, analysis of water demands for Mesa Water®'s existing service area, and the project and other development projects over a 20-year planning period. The WSA also includes an analysis of reliability of Mesa Water®'s water supplies and water quality and

concludes with an analysis describing water supply during normal, single-dry, and multiple dry years over a 20-year planning period.

### 1.1 References

The following documents were used as reference information in the development of this WSA:

1. 2015 Urban Water Management
2. 2014 Water Master Plan Update
3. OCWD Engineer's Report
4. Mesa Water District's Actual 2019 Demand Data
5. Mesa Water District's Revised Water Demand Projections

## 2.0 LEGISLATION

### 2.1 SB 610 – Water Supply Planning

SB 610 was implemented in January 2002. SB 610 requires any development that qualifies as a “Project” under Water Code 10912 to be supported with a Water Supply Assessment (WSA) report drafted specifically to identify the public water system that shall supply water to the project and analyze the availability and reliability of water supply to the development. The WSA shall include the following, if applicable to the supply conditions:

1. Discussion with regard to whether the public water system’s total projected water supplies available during normal, single dry, and multiple dry water years during a 20-year projection will meet the projected water demand associated with the proposed project, in addition to the public water system’s existing and planned future uses.
2. Identification of existing water supply entitlements, water rights, or water service contracts secured by the purveying agency and water received in prior years pursuant to those entitlements, rights, and contracts.
3. Description of the quantities of water received in prior years by the public water system under the existing water supply entitlements, water rights or water service contracts.
4. Water supply entitlements, water rights or water service contracts shall be demonstrated by supporting documentation such as the following:
  - a. Written contracts or other proof of entitlement to an identified water supply.
  - b. Copies of capital outlay program for financing the delivery of a water supply that has been adopted by the public water system.
  - c. Federal, state, and local permits for construction of necessary infrastructure associated with delivering the water supply.
  - d. Any necessary regulatory approvals that are required in order to be able to convey or deliver the water supply.
5. Identification of other public water systems or water service contract holders that receive a water supply or have existing water supply entitlements, water rights, or water service contracts, to the same source of water as the public water system.
6. If groundwater is included for the supply for a proposed project, the following additional information is required:
  - a. Description of groundwater basin(s) from which the proposed project will be supplied. Adjudicated basins must have a copy of the court order or decree adopted and a description of the amount of groundwater the public water system has the legal right to pump. For non-adjudicated basins, information on whether the DWR has identified the basin as overdrafted or has projected that the basin will become overdrafted if present management conditions continue, in the most current bulletin of DWR that characterizes the condition of the basin, and a detailed

- description of the efforts being undertaken in the basin to eliminate the long-term overdraft condition.
- b. Description and analysis of the amount and location of groundwater pumped by the public water system for the past five (5) years from any groundwater basin from which the proposed project will be supplied. Analysis should be based on information that is reasonably available, including, but not limited to, historic use records.
  - c. Description and analysis of the amount and location of groundwater projected to be pumped by the public water system from any groundwater basin from which the proposed project will be supplied. Analysis should be based on information that is reasonably available, including, but not limited to, historic use records.
  - d. Analysis of sufficiency of the groundwater from the basin(s) from which the proposed project will be supplied.
7. The WSA shall be included in any environmental document prepared for the project.
  8. The WSA may include an evaluation of any information included in that environmental document. A determination shall be made whether the projected water supplies will be sufficient to satisfy the demands of the project, in addition to existing and planned future uses.

## 2.2 SB X7-7 and EO B-37-16 and EO B-40-17

The Water Conservation Act of 2009 (SB X7-7) requires all California urban water agencies to set and meet certain demand reduction targets in order to assist the State in reducing urban water use 20 percent by 2020. The Act also requires each agency to monitor its progress toward its targets. This was implemented for the purpose of meeting the mandate to reduce per capita urban water consumption 20 percent statewide. SB X7-7 describes the overall process by which the Mesa Water District is to comply with the requirements. It specifically identifies methods for establishing urban water use targets.

Governor Jerry Brown issued a State of Emergency and Continued State of Emergency in 2014 in response to the persistent state-wide drought. In April 2015, Executive Order (EO) B-29-15 was issued by the Governor, which required a water use reduction of 25 percent, as compared to 2013 usage, throughout the State. The EO outlined specific water use reductions designed to heighten the urgency to reduce water consumption and facilitate the ability of local agencies to implement and enforce water conservation requirements.

Following unprecedented water conservation and plentiful winter rain and snow, on April 7, 2017 Governor Brown ended the drought State of Emergency in most of California, while maintaining water reporting requirements and prohibitions on wasteful practices such as water during or right after rainfall. EO B-40-17 lifts the drought emergency in all California counties except Fresno, Kings, Tulare, and Tuolumne, where emergency drinking water projects will continue to be implemented to help address diminished groundwater supplies. The Order also rescinds two



emergency proclamations from January and April 2014 and four drought-related Executive Orders issued in 2014 and 2015, as briefly discussed above. EO B-40-17 builds on actions taken in EO B-37-16, which remains in effect, to continue making water conservation a way of life in California. The State Water Resources Control Board (SWRCB) maintains urban water use report requirements and prohibitions on wasteful practices such as watering during or after rainfall, hosing off sidewalks and irrigating ornamental turf on public street medians. As directed by Governor Brown in EO B-37-16, the Board will separately take action to make reporting of wasteful water practices permanent.

The Executive Director for the SWRCB, on April 26, 2017, rescinded the water supply stress test requirements and remaining mandatory conservation standards for urban water suppliers. The action was in response to Governor Brown's earlier announcement ending the drought state of emergency and transitioning to a permanent framework for making water conservation a California way of life. Additional information can be found on the SWRCB website at:

[http://www.swrcb.ca.gov/waterrights/water\\_issues/programs/drought/emergency\\_mandatory\\_regulations.shtml](http://www.swrcb.ca.gov/waterrights/water_issues/programs/drought/emergency_mandatory_regulations.shtml)

### 3.0 ONE METRO WEST PROJECT

#### 3.1 Project Description

The One Metro West Development (Project) site is a 16.2-acre industrial area located North of Interstate 405, bounded by Sunflower Avenue and the South Coast Collection commercial development to the east and industrial uses to the west. The existing site is comprised of one building totaling 345,900 square feet of industrial use space. The existing building houses a dietary supplement manufacturer, a commercial decoration warehouse, and a frozen bakery product and supplies manufacturer. The existing industrial space, including the building, concrete sidewalks, asphalt pavement, landscaping, etc. will be demolished and replaced with the proposed Project.

The Developer plans to set aside 0.45 acres to OCTA along I-405 for future widening. The new development will occupy the remaining 15.75 acres and consist of three residential apartment buildings comprised of 1,057 dwelling units, and 6,000 square feet of specialty retail. A fourth building will contain 25,000 square feet of commercial creative office space. Each building is also equipped with one or more of the following parking options: below grade parking structure, above grade parking structure, at-grade parking stalls. The One Metro West Development will also have 1.5 acres of publicly irrigated open space, plus an additional 0.75 acres of landscaped median along Sunflower Avenue. Table 3-1 summarizes the existing and proposed developments.

Table 3-1: Existing and Proposed Development

Land Use	Classification	Dwelling Units / Building Area	Land Area
<b>Existing</b>			
Industrial	Industrial	345,900 SF	16.2 Acres
<b>Proposed</b>			
Residential	Medium/High Density	1,057	--
Creative Office	Commercial	25,000 SF	--
Retail	Commercial	6,000 SF	--
Park	Open Space	--	1.5 Acres
Landscaped Median	Open Space	--	0.75 Acres

#### 3.2 Project Water Demands

The land use changes proposed as part of this Project will result in increased water demands. The proposed demands were estimated based upon demand factors and peaking factors established in the 2014 Water Master Plan (2014 WMP). It is assumed that the demand factors listed in the 2014 WMP account for both indoor and outdoor water consumption based on their respective land use category. Mesa Water®’s 2014 Water Master Plan does not specify irrigation demand factors based on land use type. Since the percentage of common irrigated area is a significant portion of the total development area, Michael Baker estimated a separate irrigation demand factor for this development. The irrigation demand factor is based off industry standards in similarly developed cities. See Table 3-2 for the water demand factors used in this analysis.

Table 3-2: Water Demand Factors <sup>[1]</sup>

Water Demand Factor Classification	Average Annual Demand (AAD)	Max Day Demand (MDD) (AAD*1.5)	Peak Hour Demand (PHD) (MDD*1.5)
<b>Residential</b>			
Low Density Residential ( $\leq 25$ DU's/Ac)	2,500 gpd/acre	3,750 gpd/acre	5,625 gpd/acre
Mid/High Density Residential ( $>25$ DU's/ Ac)	4,500 gpd/acre	6,750 gpd/acre	10,125 gpd/acre
<b>Non-Residential</b>			
Commercial	2,500 gpd/acre	3,750 gpd/acre	5,625 gpd/acre
Industrial	3,000 gpd/acre	4,500 gpd/acre	6,750 gpd/acre
Irrigation <sup>[2]</sup>	2,400 gpd/acre	--	--

[1] Source: 2014 Water Master Plan Technical Memoranda No. 1.2, prepared by Carollo Engineers

[2] Irrigation demands developed by Michael Baker using industry standard data

The existing site is occupied by a 345,900 square foot industrial building. Mesa Water District provided meter data for the FY 2019, which indicated a total water usage of 7,819 hundred cubic feet (CCF) for the year. The meter data indicates less water usage that would be expected from a manufacturing facility of this size, which means that the facility may have been abandoned part way through the year. Table 3-3 contains the existing project site demand.

Table 3-3: Existing Water Demands <sup>[1]</sup>

Land Use	Site Acreage	Building Square Footage	Average Day Demand [1]		Maximum Day Demand (MDD) (ADD*1.5)		Peak Hour Demand (PHD) (MDD*1.5)
			(gpd)	(gpm)	(gpm)	(gpm)	(gpm)
Industrial	16.2	345,900	16,024	11.13	24,036	16.69	25.04

[1] Source: Based on FY 2019 Mesa Water District meter data.

Similarly, the proposed commercial and irrigation demands were calculated using Mesa Water’s published demand factors. The calculations for those demands are summarized in Table 3-4.

To develop the residential demands, Michael Baker calculated the development density using the ratio of the total number of dwelling units to the total development area. The calculated density is 67.11 DU/Ac. This density value places the development within the most dense land use category that Mesa Water District publishes in the 2014 Water Master Plan Technical Memoranda No. 1.2, the Mid/High Land Use category. However, the Mid/High land use factor covers any land use density greater than 25 DU/acre. Typically, developments that fall into the Mid/High density land use category, in Mesa Water®’s service area, are less than 40 DU/acre.

Using the published demand factor would result in demands being artificially lower than can generally be expected from a development of this size. Therefore, Michael Baker developed a modified demand factor to account for the discrepancy between the land use density and the actual development density. The modified demand factor is developed by converting from demand per acre to demand per dwelling unit using the calculation in Equation 3-1.

Equation 3-1:

$$\text{Modified Demand Factor} = \frac{4,500 \text{ gpd/acre}}{25 \text{ DU/Ac}} = 180 \text{ gpd/DU}$$

The modified demand factor was used to calculate the proposed development’s average day demand. The demand calculation using the modified demand factor is summarized in Table 3-4.

Table 3-4: Project Water Demands <sup>[1]</sup>

Land Use	Category	DU	Area (Ac)	Average Day Demand			Maximum Day Demand		Peak Hour Demand
				(gpd)	(gpm)	(AFY)	(gpd)	(gpm)	(gpm)
Residential	Mid/High	1,057	--	190,260	132.13	213.13	285,390	198.19	297.28
Commercial	--	--	0.71	1,779	1.24	2.00	2,669	1.85	2.78
Irrigation <sup>[2]</sup>	--	-	2.25	5,400	3.75	6.05	13,500	9.38	25.03
<b>Total</b>				<b>197,439</b>	<b>137.12</b>	<b>221.18</b>	<b>301,559</b>	<b>209.4</b>	<b>325.1</b>

[1] Demand and peaking factors based on Table 3-2.

[2] Irrigation peaking factors based on industry standard data. Maximum Day= 2.5xAAD. Peak Hour Demand is MDDx2.67.

Based upon the proposed land use, the total average water demand for the Project is expected to increase the total system demand for this site. The total increase in demand is calculated in Table 3-5.

Table 3-5: Net Increase in Demand

Condition	Average Day Demand			Maximum Day Demand		Peak Hour Demand
	(gpd)	(gpm)	(AFY)	(gpd)	(gpm)	(gpm)
Existing	16,024	11.13	17.95	24,036	16.69	25.04
Proposed	197,439	137.12	221.18	301,559	209.42	325.09
<b>Net Increase</b>	<b>181,416</b>	<b>125.99</b>	<b>203.23</b>	<b>277,523</b>	<b>192.72</b>	<b>300.06</b>

## 4.0 MESA WATER DISTRICT WATER DEMAND

### 4.1 Overview

Since the last UWMP update, southern California’s urban water demand landscape has been largely shaped by the efforts to comply with SB X7-7. This law requires all of California’s retail urban water suppliers serving more than 3,000 acre-feet per year (AFY) or 3,000 service connections to achieve a 20 percent reduction in demands (from a historical baseline) by 2020. Mesa Water® has been actively engaged in efforts to reduce water use in its service area to meet the 2020 final water use target. Meeting this target is critical to ensure that Mesa Water® remains eligible to receive future state water grants and loans.

In April 2015, Governor Jerry Brown issued an Emergency Drought Mandate as a result of one of the most severe droughts in California’s record, requiring a collective reduction in statewide urban water use of 25 percent by February 2016. In response to the Governor’s mandate, Mesa Water® carried out more concentrated conservation efforts. It has also implemented higher (more restrictive) stages of its Water Conservation and Water Supply Emergency Program to achieve its demand reduction target of 20 percent prescribed by the California State Water Resources Control Board (SWRCB).

In addition to local water conservation ordinances, Mesa Water® has engaged in activities that include being a signatory member of the California Urban Water Conservation Council’s (CUWCC) Best Management Practices (BMP) Memorandum of Understanding (MOU) since 1994 and participating in water audit and leak detection programs. Mesa Water® has also partnered with MWDOC on educational programs, retrofits, and trainings.

These efforts have been part of statewide water conservation ordinances that require modifications to watering landscape watering, serving water in restaurants and bars, and reducing the amount of laundry cleaned by hotels.

The purpose of this section is to analyze Mesa Water®’s current water demands by customer type, factors that influence those demands, and projections of future water demands for the next 20 years. In addition, to satisfy SB X7-7 requirements, this section provides details of Mesa Water®’s SB X7-7 compliance method selection, baseline water use calculation, and 2015 and 2020 water use targets.

### 4.2 Factors Affecting Demand

Water demands within the Mesa Water® service area is dependent on many factors such as local climate conditions and the evolving hydrology of the region, demographics, land use characteristics, and economics are key factors of affecting demand for Mesa Water®. In addition to local factors, the watersheds of California’s imported water are experiencing drought conditions and impacting available and future water supplies.

#### 4.2.1 Climate Characteristics

Mesa Water® is located within the South Coast Air Basin (SCAB) that encompasses all of Orange County, and the urban areas of Los Angeles, San Bernardino, and Riverside counties. The SCAB climate is characterized by southern California’s “Mediterranean” climate: a semi-arid environment with mild winters, warm summers and moderate rainfall.

The average temperature ranges from 53.6°F in December to 68.8°F in August. Annual precipitation averages 10.6 inches, occurring mostly between November and March. The average evapotranspiration (ET) is about 45.6 inches per year, which is almost four times the annual average rainfall.

Local rainfall has limited impacts on reducing irrigation demand for Mesa Water®. Water that infiltrates into the soil may enter groundwater supplies depending on the local geography. However, due to the large extent of impervious cover in southern California, rainfall runoff quickly flows to a system of concrete storm drains and channels that lead directly to the ocean. OCWD is one agency that has successfully captured stormwater in the Santa Ana River for years and used it as an additional source of supply for groundwater recharge. There is growing awareness regarding the beneficial use of capturing and using stormwater as a local source and is anticipated to continue developing in the future.

Metropolitan's water supplies come from the State Water Project (SWP) and the Colorado River Aqueduct (CRA), influenced by climate conditions in northern California and the Colorado River Basin, respectively. Both regions have been suffering from multi-year drought conditions with record low precipitation which directly impact water supplies to southern California.

#### 4.2.2 Demographics

Water is delivered to a current population of 110,000 according to the latest population estimate from Mesa Water®. The Mesa Water® service area population is projected to increase by 3 percent by 2040 representing an average growth rate of 0.1 percent per year. A population update will be conducted when the Mesa Water District boundaries are re-evaluated in 2022. In addition to the permanent population, the Mesa Water District service area attracts a significant number of visitors during the summer months and contributes to increased water demands. Furthermore, housing is becoming denser as new residential developments within Mesa Water District’s boundary are more frequently multi-storied. Table 4-1 shows the population projections in five-year increments out to 2040 within the Mesa Water® service area.

Table 4-1: Population - Current and Projected

Retailed: Population-- Current and Projected					
Population Served	2020	2025	2030	2035	2040
	110,000	110,552	111,105	111,662	112,222

#### 4.2.3 Land Use

The Mesa Water® service area can best be described as a predominately residential single and multi-family community located along the coast in central Orange County, close to scenic beaches and natural preserves. The influx of tourists during the summer months creates higher demands within the Mesa Water® service area, especially at the beach facilities, hotels and restaurants.

#### 4.3 Water Use by Customer Type

An agency's water consumption can be projected by understanding the type of use and customer type creating the demand. Developing local water use profiles helps to identify when, where, how, quantity of water used, and by whom within the agency's service area. A comprehensive profile of the agency's service area enables the impacts of water conservation efforts to be assessed and to project the future benefit of water conservation programs.

The following sections of this UWMP provide an overview of Mesa Water® customer water consumption by customer account type as follows:

- Single-family Residential
- Multi-family Residential
- Commercial
- Institutional/ Government

Other water uses including sales to other agencies and non-revenue water are also discussed in this section.

##### 4.3.1 Overview

There are approximately 25,000 current customer active service connections ranging in size from 5/8" to 10" in the Mesa Water® distribution system with all existing connections metered, there are no inactive connections. Approximately 70 percent of Mesa Water®'s water demand is residential, approximately 21 percent for Commercial, Industrial, and Institutional users, approximately 8 percent dedicated landscape irrigation, and the remaining less than one percent for other uses such as construction hydrant meters and fire-line testing.

Table 4-2 contains a summary of the Mesa Water® service area total water demand in fiscal year (FY) 2014-15 and the FY 2018-19 for potable water usage.

Table 4-2: Demands for Potable Water – Actual (AF)

Retail: Demands for Potable- Actual			
Use Type	Level of Treatment When Delivered	2015 Actual	2019 Actual <sup>[1]</sup>
		Volume	Volume
Single Family	Drinking Water	5,158	5,673
Multi-Family	Drinking Water	5,112	5,622
Institutional/Governmental	Drinking Water	1,137	843
Commercial	Drinking Water	3,242	2,362
Industrial	Drinking Water	301	242
Landscape	Drinking Water	1,879	1,309
Other	Drinking Water	15	14
Total		16,844	16,065
Note: [1] 2018 Land use breakdown volumes are approximate and were based on 2015 land use breakdown values and approximate land use percentages discussed in Section 4.3.1.			

Source: Mesa Water District 2015 UWMP Table 2-2

#### 4.3.2 Non-Residential

Non-residential demands include commercial and dedicated landscape use. Mesa Water® has a mix of commercial uses (markets, shopping centers, restaurants, office complexes, etc.) and public entities (schools, airport, fairgrounds, fire stations, and government offices), that account for 21 percent of total demand. Dedicated landscape for public park facilities, businesses, and golf courses accounts for 8 percent of total potable demand.

#### 4.3.3 Sales to Other Agencies

Mesa Water® does not currently sell water to other agencies.

#### 4.3.4 Non-Residential

Non-revenue water is defined by the American Water Works Association (AWWA) to include the sum of specific types of water loss and any authorized, unbilled consumption that occurs within the water distribution system. Non-revenue water consists of three components: unbilled authorized consumption (e.g. hydrant flushing, firefighting, and blow-off water from well start-ups), real losses (e.g. leakage in mains and service lines), and apparent losses (unauthorized consumption and metering inaccuracies).

A water loss audit was conducted per AWWA methodology for Mesa Water® to understand the relation between water loss and revenue losses. This audit was developed by the AWWA Water Loss Task Force as a universal methodology that could be applied to any water distribution system. This audit meets the requirements of SB 1420 that was signed into law in September



2014. Understanding and controlling water loss from a distribution system is an effective way for Mesa Water® to achieve regulatory standards and manage their existing resources.

Table 4-3 below is a result of the AWWA Water Audit completed for Mesa Water®. The water loss summary was calculated over a one-year period from available data and the methodology explained above. The volume of water loss calculated for this period represents 2.2 percent of Mesa Water®’s annual water supplied, this presents an opportunity to identify areas of high water loss and develop strategies to minimize it.

Table 4-3: Water Loss Audit Summary

Retail: 12 Month Water Loss Audit Reporting	
Reporting Period Start Date (mm/yyyy)	Volume of Water Loss
07/2018	343 AF

Source: Mesa Water District FY 2019 Water Audit

#### 4.4 Demand Projections

Demand projections were developed by Mesa Water® within their service area based on available data as well as land use, population and economic growth per the Master Plan that was adopted in November 2014.

##### 4.4.1 Demand Projection Methodology

The water demand projections were an outcome of Mesa Water®’s Master Plan based on land use within the service area. Future land uses and development projects were individually identified by parcel for the Master Plan through two approaches. The first approach was to review all development plans that were received by the City of Costa Mesa Planning Department in 2012 and 2013. Eight developments of at least 14 units were deemed to be of a sufficient size to impact future water use within the service area and were included in the future demand forecast (Mesa Water® Master Plan, Carollo, November 2014). The second approach used aerial imagery of the service area to identify vacant lots and potential infill sites for future developments. Identified parcels included residential and commercial areas and were assumed to follow the zoning designation from the City of Costa Mesa 2004 General Plan Land Use Map.

Together the two approaches identified over 82 acres of parcels for future development within the service area for a corresponding demand projection of 357 AF, see Table 4-4 for a summary of the land use breakdown and projected demand breakdown.

Table 4-4: Projected Future Development Demand

Retail: Projected Future Development Demand			
Land Use Type	Water Demand Factor (gpd/acre)	Area (acres)	Projected Demand (AFY)
Low Density Residential	2,500	11.3	32
Mid/High Density Residential	4,500	53.5	270
Commercial	2,500	5.0	14
Industrial	3,000	12.4	42
<b>Total</b>	<b>N/A</b>	<b>82.3</b>	<b>357</b>

Source: Mesa Water District 2014 Water Master Plan Technical Memoranda 1.2, Table 10

Linear interpolation was used to project demands out to 2040 as shown in Section 4.4.3. The Banning Ranch Development water demand of 614 AFY was evaluated but not included in demand projections as the timing of this development is unknown.

#### 4.4.2 Agency Refinement

Demand projections were developed by Mesa Water® as part of their 2014 Master Plan (Mesa Water® Master Plan, Carollo, November 2014) and used as the basis of the 2015 UWMP.

#### 4.4.3 Projections throughout 2040

A key component of the 2015 UWMP is providing insight into Mesa Water®’s future water demand outlook. Mesa Water®’s 2015 UWMP potable water demand forecast was estimated to be 16,844 AFY, met through locally pumped groundwater. Table 4-5 contains a projection of the potable water demands through the year 2040.

Table 4-5: Demands for Potable Water- Projected (AF)

Retail: Demands for Potable- Projected						
Use Type	Projected Water Use					
	<i>Report to the Extent that Records are Available</i>					
	2019 Actual <sup>[1]</sup>	2020 <sup>[2]</sup>	2025	2030	2035	2040
Single Family	5,673	5,964	5,975	5,995	6,015	6,036
Multi-Family	5,622	5,911	5,922	5,942	5,962	5,982
Institutional/Governmental	843	1,305	1,316	1,321	1,325	1,330
Commercial	2,362	3,744	3,755	3,767	3,780	3,793
Industrial	242	338	349	350	351	353
Landscape	1,309	2,166	2,176	2,184	2,191	2,198
Other	14	16	17	17	17	17
<b>Total</b>	<b>16,065</b>	<b>19,444</b>	<b>19,510</b>	<b>19,576</b>	<b>19,641</b>	<b>19,709</b>

[1] See Table 4-2

[2] Mesa Water District 2019 Water Usage Forecast  
Source: Mesa Water District 2015 UWMP Table 2-4

The above demand values were provided by Mesa Water® to MWDOC as part of the UWMP effort. As the regional wholesale supplier of Orange County, MWDOC works in collaboration with each of its retail agencies as well as Metropolitan, its wholesaler, to develop demand projections for imported water, if any. Mesa Water® has decreased its reliance on imported water by pursuing a variety of local groundwater supplies and water conservation strategies and with population expected to increase minimally, Mesa Water® per capita water use is projected to decrease as detailed in Section 4.5 below. Note future water savings and lower income residential demands are included in projections.

The demand data presented in this section accounts for passive savings in the future. Passive savings are water savings as a result of Codes, Standards, Ordinances, or Transportation and Land Use Plans as well as public outreach on water conservation and higher efficiency fixtures. Passive savings are anticipated to continue for the next 25 years and will result in continued water saving and reduced consumption levels.

#### 4.4.4 Total Water Demand Projections

Based on the information provided above, the total demand for potable water is listed below in Table 4-6. It should be noted that the actual FY 2019 water demands were 16,065 AF, 18 percent lower than the 2020 forecasted water demands from Table 4-5. The actual to-date FY 2020 water demands are approximately 8 percent lower than the planned water budget of 17,748 AF. It is expected that demands will minimally increase over the next several years due to demand hardening as a result of the 2015 mandatory state drought reductions.

Table 4-6: Total Water Demands (AF)

Retail: Total Water Demands						
	2019	2020	2025	2030	2035	2040
Potable Water	16,065	19,444	19,510	19,576	19,642	19,709
Total Water Demand	16,065	19,444	19,510	19,576	19,642	19,709

Source: Mesa Water District 2019 Water Usage Forecast

#### 4.5 SB X7-7 Requirements

SB X7-7, signed into law on February 3, 2010, requires the State of California to reduce urban water use by 20 percent by the year 2020. Mesa Water® must determine baseline water use during their baseline period and water use targets for the years 2015 and 2020 to meet the state’s water reduction goal. Mesa Water® may choose to comply with SB X7-7 individually or as a region in collaboration with other retail water suppliers. Under the regional compliance option, Mesa Water® is still required to report its individual water use targets. Mesa Water® is required to be in compliance with SB X7-7 either individually or as part of the alliance, or demonstrate they have a plan or have secured funding to be in compliance, in order to be eligible for water related state grants and loans on and after July 16, 2016.

4.5.1 2015 and 2020 Targets

Under Compliance Option 1, the simple 20 percent reduction, the Mesa Water® 2015 target is 162 GPCPD and the 2020 target is 144 GPCPD as summarized in Table 4-7. The 2015 target is the midway value between the 10-year baseline and the confirmed 2020 target. In addition, the confirmed 2020 target needs to meet a minimum of 5 percent reduction from the five-year baseline water use.

Table 4-7: Baselines and Targets Summary

Baselines and Targets Summary					
Baseline Period	Start Year	End Year	Average Baseline GPCPD*	2015 Interim Target*	Confirmed 2020 Target*
10-15 Year	1996	2005	180	162	144
5 Year	2004	2008	177		

\*All values are in Gallons per Capita per Day (GPCPD)

Source: Mesa Water District 2015 UWMP Table 2-9

Table 4-8 compares Mesa Water® 2015 water use target to its actual 2015 consumption. Based on this comparison, Mesa Water® is in compliance with its 2015 interim target and has already achieved the 2020 water use target, assuming water usage between 2016 and 2020 does not increase beyond the 2020 target.

Table 4-8: 2015 Compliance

Actual 2015 GPCPD*	2015 Interim Target GPCPD*	Did Supplier Achieve Targeted Reduction for 2015? Y/N
108	162	Yes

\*All values are in Gallons per Capita per Day (GPCPD)

Source: Mesa Water District 2015 UWMP Table 2-10

## 5.0 WATER SOURCES AND SUPPLY RELIABILITY

### 5.1 Overview

Mesa Water® currently relies on a combination of clear and amber-tinted groundwater from the Orange County Groundwater Basin for 100 percent of its demands. Mesa Water® works together with three primary agencies, Metropolitan, MWDOC, and OCWD to ensure a safe and reliable water supply that will continue to serve the community in periods of drought and shortage. Mesa Water®’s projected water supply portfolio is shown on Figure 5-1.

Figure 5-1: Water Supply Sources in Mesa Water® (AF)

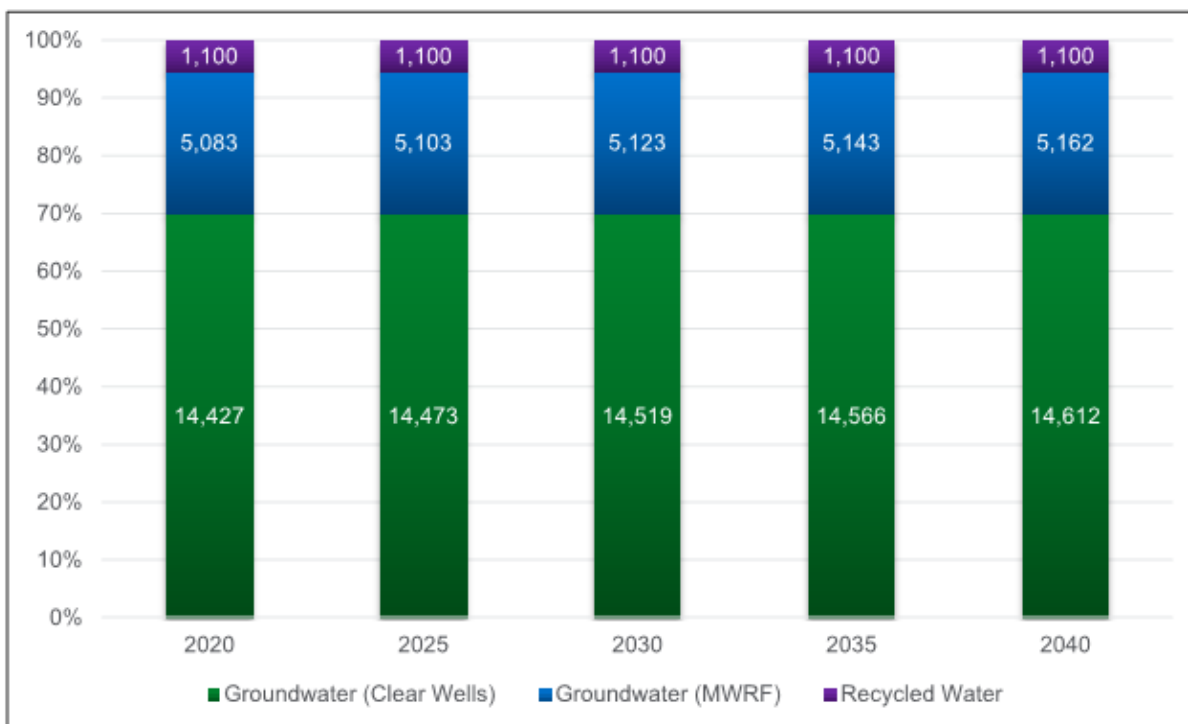

Source: Mesa Water District 2015 UWMP Figure 3-1

The following sections provide a detailed discussion of Mesa Water®’s water sources as well as the future water supply portfolio for the next 25 years. Additionally, Mesa Water®’s projected supply and demand under various hydrological conditions are compared to determine Mesa Water®’s supply reliability for the 25-year planning horizon.

### 5.2 Imported Water

Mesa Water® also has the ability to supplement its local groundwater with imported water purchased from Metropolitan through MWDOC. Metropolitan’s principal sources of water are the Colorado River via the CRA and the Lake Oroville watershed in Northern California through the SWP. The water obtained from these sources is treated at the Robert B. Diemer Filtration Plant located north of Yorba Linda. Typically, the Diemer Filtration Plant receives a blend of

Colorado River water from Lake Mathews through the Metropolitan Lower Feeder and SWP water through the Yorba Linda Feeder. In the past, imported water has represented up to about one third of Mesa Water®’s total annual supply, however, since the MWRf came on-line in January 2013, Mesa Water® has not needed to import water to meet demand. When requested by OCWD, Mesa Water® participates in the Coastal Pumping Transfer Program (CPTP) and receives a pre-determined amount of its groundwater pumping allocation from imported water. While Mesa Water® is currently 100 percent reliant on local sources, Mesa Water® also maintains imported water connections as backup to local supplies. Mesa Water® can obtain imported water from MWDOC through four connections as listed in Table 5-1.

The combined capacity from these connections is rated at approximately 42 mgd. However, the actual capacity that can be obtained is determined by the difference in hydraulic grade line (HGL) between the imported water transmission main and Mesa Water®’s distribution system as well as the conveyance capacity within Mesa Water®’s distribution system.

Mesa Water® has two metered interconnections with the City of Huntington Beach and the Irvine Ranch Water District (IRWD). In addition, there are 16 emergency interconnections with the City of Santa Ana, City of Newport Beach, and IRWD.

Table 5-1: Imported Water Capacity

Imported Water Pipeline/Turnout	Active Number of Turnouts	Turnout Capacity (cfs)	Turnout Capacity (AFY)	Maximum Delivery Capacity (mgd)
OC-44	3	67	48,506	43.3
OC-14	1	10	7,239	6.5
CM-2	1	15	10,859	9.7
CM-6	1	4	2,896	2.6
<b>Subtotal</b>	<b>6</b>	<b>96</b>	<b>69,500</b>	<b>62.1</b>

Although Mesa Water® has historically relied on imported water to supplement its demands, Mesa Water® is projected to meet its future demands using local groundwater through 2040.

### 5.3 Groundwater

Historically, local groundwater has been the cheapest and most reliable source of supply for Mesa Water®. In FY 2019 Mesa Water® relied on approximately 16,065 AFY of groundwater from the OC Basin. This source of supply meets approximately 100 percent of Mesa Water®’s total annual demand.

This section provides a description of the OC Basin and the management measures taken by OCWD to optimize local supply and minimize overdraft. This section also provides information on historical groundwater production as well as a 25-year projection of Mesa Water®’s groundwater supply.

### 5.3.1 Basin Characteristics

The OC Basin underlies the northerly half of Orange County beneath broad lowlands. The OC Basin covers an area of approximately 350 square miles, bordered by the Coyote and Chino Hills to the north, the Santa Ana Mountains to the northeast, and the Pacific Ocean to the southwest. The OC Basin boundary extends to the Orange County-Los Angeles Line to the northwest, where groundwater flows across the county line into the Central Groundwater Basin of Los Angeles County. The total thickness of sedimentary rocks in the OC Basin is over 20,000 feet, with only the upper 2,000 to 4,000 feet containing fresh water. The Pleistocene or younger aquifers comprising this OC Basin are over 2,000 feet deep and form a complex series of interconnected sand and gravel deposits. The OC Basin's full volume is approximately 509,000 AF, for more information on The OC Basin operations, see the OCWD Annual Engineer's Report.

There are three major aquifer systems that have been subdivided by OCWD, the Shallow Aquifer System, the Principal Aquifer System, and the Deep Aquifer System. These three aquifer systems are hydraulically connected as groundwater is able to flow between each other through intervening aquitards or discontinuities in the aquitards. The Shallow Aquifer system occurs from the surface to approximately 250 feet below ground surface. Most of the groundwater from this aquifer system is pumped by small water systems for industrial and agricultural use. The Principal Aquifer system occurs at depths between 200 and 1,300 feet below ground surface. Over 90 percent of groundwater production is from wells that are screened within the Principal Aquifer system. Only a minor amount of groundwater is pumped from the Deep Aquifer system, which underlies the Principal Aquifer system and is up to 2,000 feet deep in the center of the OC Basin. The three major aquifer systems are shown on Figure 5-2.

Figure 5-2: Map of the Orange County Groundwater Basin and Its Major Aquifer Systems

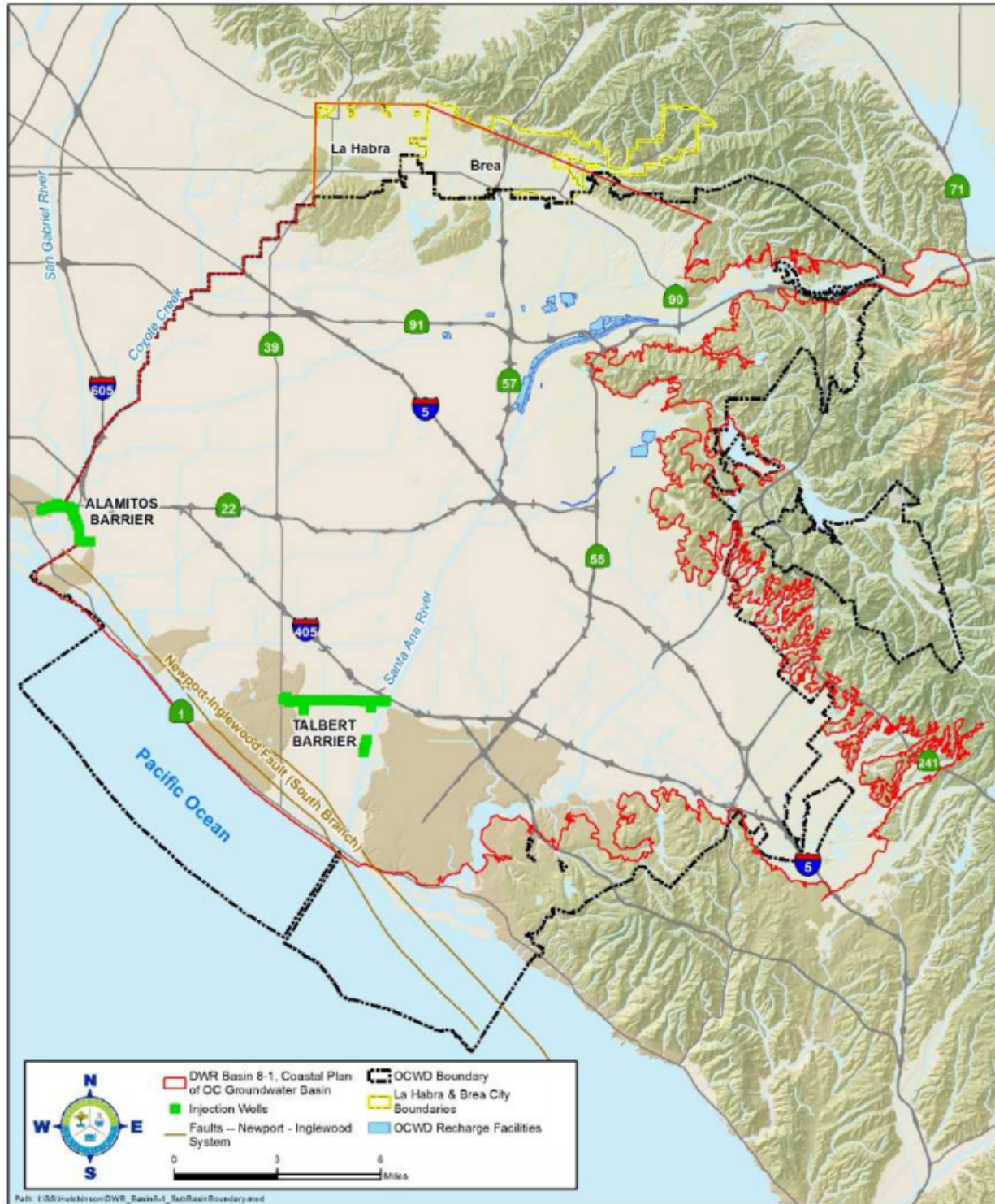



The OCWD was formed in 1933 by a special legislative act of the California State Legislature to protect and manage the County's vast, natural, groundwater supply using the best available technology and defend its water rights to the OC Basin. This legislation is found in the State of California Statutes, Water – Uncodified Acts, Act 5683, as amended. The OC Basin is managed by OCWD under the Act, which functions as a statutorily-imposed physical solution.

Groundwater levels are managed within a safe basin operating range to protect the long-term sustainability of the OC Basin and to protect against land subsidence. OCWD regulates groundwater levels in the OC Basin by regulating the annual amount of pumping (OCWD, Groundwater Management Plan 2015 Update, June 2015).

### 5.3.2 Basin Production Percentage

The OC Basin is not adjudicated and as such, pumping from the OC Basin is managed through a process that uses financial incentives to encourage groundwater producers to pump a sustainable amount of water. The framework for the financial incentives is based on establishing the basin production percentage (BPP), the percentage of each Producer's total water supply that comes from groundwater pumped from the OC Basin. Groundwater production at or below the BPP is assessed a Replenishment Assessment (RA). While there is no legal limit as to how much an agency can pump from the OC Basin, there is a financial disincentive to pump above the BPP. Agencies that pump above the BPP are charged the RA plus the Basin Equity Assessment (BEA), which is calculated so that the cost of groundwater production is approximately equal to MWDOC's full-service rate. The BEA can be increased to discourage production above the BPP. The BPP is set uniformly for all Producers by OCWD on an annual basis.

The BPP is set based on groundwater conditions, availability of imported water supplies, and Basin management objectives. The supplies available for recharge must be estimated for a given year. The supplies of recharge water that are estimated are: 1) Santa Ana River stormflow, 2) Natural incidental recharge, 3) Santa Ana River baseflow, 4) GWRS supplies, and 5) other supplies such as imported water and recycled water purchased for the Alamitos Barrier. The BPP is a major factor in determining the cost of groundwater production from the OC Basin for that year.

In some cases, OCWD encourages treating and pumping groundwater that does not meet drinking water standards in order to protect water quality. This is achieved by using a financial incentive called the BEA Exemption. A BEA Exemption is used to clean up and contain the spread of poor quality water. OCWD uses a partial or total exemption of the BEA to compensate a qualified participating agency or Producer for the costs of treating poor quality groundwater. When OCWD authorizes a BEA exemption for a project, it is obligated to provide the replenishment water for the production above the BPP and forgoes the BEA revenue that OCWD would otherwise receive from the producer (OCWD, Groundwater Management Plan 2015 Update, June 2015).

There are multiple sources of information available that state the pumping capacity of Mesa Water®’s groundwater wells. The status and pump capacities of Mesa Water®’s clear water wells are listed in Table 5-2, while the amber wells are listed in Table 5-3.

Table 5-2: Clear Water Wells Capacity

Source	Status	Well Capacity (gpm)	Well Capacity (mgd)	Well Capacity (AFY)
Well 1	Active	2,400	3.47	3,871
Well 3	Active	2,260	3.25	3,644
Well 5	Active	3,800	5.47	6,128
Well 7	Active	1,500	2.16	2,420
Well 9	Active	1,980	2.85	3,194
<b>Total Active Pumping Capacity</b>		<b>11,940</b>	<b>17.19</b>	<b>19,259</b>
Well 12	Future	3,000	4.32	4,840
Well 14	Future	3,000	4.32	4,840
<b>Total Active and Future Pumping Capacity</b>		<b>17,940</b>	<b>25.83</b>	<b>28,937</b>

Table 5-3: Amber Wells and MWRf Capacity

Source	Current Status	2019 Capacity (gpm)	2019 Capacity (mgd)	2019 Capacity (AFY)
Well 6	Active	3,000	4.32	4,840
Well 11	Active	5,000	7.20	8,065
Well Pumping Capacity		8,000	11.52	12,904
<b>MWRf Treatment Capacity</b>		<b>6,000</b>	<b>8.64</b>	<b>9,678</b>

The clear water wells have a capacity of 17.19 MGD, or 19,259 AFY. The Mesa Water Reliability Facility (MWRf) treats amber colored water from two wells and have a combined capacity of 8.64 MGD, or 9,678 AFY.

*5.3.2.1 2015 OCWD Groundwater Management Plan*

OCWD was formed in 1933 by the California legislature to manage and operate the OC Basin in order to protect and increase the OC Basin’s sustainable yield in a cost-effective manner. As previously mentioned, the BPP is the primary mechanism used by OCWD to manage pumping in the OC Basin. In 2013, OCWD’s Board of Directors adopted a policy to establish a stable BPP with the intention to work toward achieving and maintaining a 75 percent BPP by FY 2015-16. Although BPP is set at 75 percent, based on discussions with OCWD a conservative BPP of 70 percent is assumed through 2040. Principles of this policy include:

- OCWD’s goal is to achieve a stable 75 percent BPP, while maintaining the same process of setting the BPP on an annual basis, with the BPP set in April of each year after a public hearing

has been held and based upon the public hearing testimony, presented data, and reports provided at that time.

- OCWD must manage the OC Basin in a sustainable manner for future generations. The BPP will be reduced if future conditions warrant the change.
- Each project and program to achieve the 75 percent BPP goal will be reviewed individually and assessed for their economic viability.

The OC Basin’s storage levels would be managed in accordance to the 75 percent BPP policy. It is presumed that the BPP will not decrease as long as the storage levels are between 100,000 and 300,000 AF from full capacity. If the OC Basin is less than 100,000 AF below full capacity, the BPP will be raised. If the OC Basin is over 350,000 AF below full capacity, additional supplies will be sought after to refill the OC Basin and the BPP will be lowered.

The OC Basin is managed to maintain water storage levels of not more than 500,000 AF below full condition to avoid permanent and significant negative or adverse impacts. Operating the OC Basin in this manner enables OCWD to encourage reduced pumping during wet years when surface water supplies are plentiful and increase pumping during dry years to provide additional local water supplies during droughts.

OCWD determines the optimum level of storage for the following year when it sets the BPP each year. Factors that affect this determination include the current storage level, regional water availability, and hydrologic conditions. When the OC Basin storage approaches the lower end of the operating range, immediate issues that must be addressed include seawater intrusion, increased risk of land subsidence, and potential for shallow wells to become inoperable due to lower water levels (OCWD, Groundwater Management Plan 2015 Update, June 2015).

*5.3.2.2 OCWD Engineer’s Report*

The OCWD Engineer’s Report reports on the groundwater conditions and investigates information related to water supply and Basin usage within OCWD’s service area. The 2017-2018 Engineer’s Report indicates the total groundwater recharge, the total groundwater production, and the accumulated overdraft (AOD). Table 5-4 contains these values, and more information on the OC Groundwater Basin can be found in the OCWD Engineer’s Report, available on the OCWD website.

Table 5-4: OC Groundwater Basin Summary

<b>Retail: Orange County Groundwater Basin Summary</b>	
Groundwater Recharge	352,637 AF
Groundwater Production	301,637 AF
Accumulated Overdraft (AOD)	(329,730) AF

Source: OCWD Engineer’s Report Appendix 5

### 5.3.3 Groundwater Historical Extraction

Pumping limitations set by the OCWD Basin Production Percentage (BPP) and the pumping capacity of the wells are the only constraints affecting the groundwater supply to Mesa Water®. A summary of the groundwater volume pumped by Mesa Water® is shown in Table 5-5.

Table 5-5: Groundwater Volume Pumped (AF)

Retail: Groundwater Volume Pumped		
Groundwater Type	Location or Basin Name	FY 2019
Alluvial Basin	Orange County Groundwater Basin	16,065
Total		16,065

Source: Mesa Water District 2015 UWMP Table 3-1

### 5.4 Summary of Existing and Planned Sources of Water

The actual and projected sources and volume of water for the year 2015 are displayed in Table 5-6 and Table 5-7 respectively.

Table 5-6: Water Supplies, Actual (AF)

Retail: Water Supplies - Actual				
Water Supply	Additional Detail on Water Supply	Water Quality	FY 2015	FY 2018
			Actual Volume	Actual Volume
Groundwater	Orange County Groundwater Basin	Drinking Water	17,655	17,202
Total			17,655	17,202

Source: Mesa Water District 2015 UWMP Table 3-2

Table 5-7: Water Supplies, Projected (AF)

Retail: Water Supplies - Projected						
Water Supply	Additional Detail on Water Supply	Projected Water Supply				
		2020 <sup>[1]</sup>	2025	2030	2035	2040
		Reasonably Available Volume	Reasonably Available Volume	Reasonably Available Volume	Reasonably Available Volume	Reasonably Available Volume
Groundwater	Clear Wells	19,259	28,937	28,937	28,937	28,937
Groundwater	MWRF	9,678	9,678	9,678	9,678	9,678
Total		28,937	38,615	38,615	38,615	38,615

[1] Mesa Water District’s FY 19 Water Supply Report

### 5.5 Supply Reliability

#### 5.5.1 Overview

Every urban water supplier is required to assess the reliability of their water service to its customers under normal, dry, and multiple dry water years. Mesa Water® depends on 100

percent local groundwater supplies to meet its water demands and has taken numerous steps to ensure it has adequate supplies. While Mesa Water® does not project the delivery of imported water, the development of numerous local projects increases the reliability of the imported water system. There are various factors that may impact reliability of supplies such as legal, environmental, water quality and climatic which are discussed below. The water supplies are projected to meet full-service demands; Metropolitan’s 2015 UWMP finds that Metropolitan is able to meet, full-service demands of its member agencies starting 2020 through 2040 during normal years, single dry year, and multiple dry years, in case Mesa Water® should need to supplement its local supplies with imported water.

Metropolitan’s 2015 Integrated Water Resources Plan (IRP) update describes the core water resources that will be used to meet full-service demands at the retail level under all foreseeable hydrologic conditions from 2020 through 2040. The foundation of Metropolitan’s resource strategy for achieving regional water supply reliability has been to develop and implement water resources programs and activities through its IRP preferred resource mix. This preferred resource mix includes conservation, local resources such as water recycling and groundwater recovery, Colorado River supplies and transfers, SWP supplies and transfers, in-region surface reservoir storage, in-region groundwater storage, out-of-region banking, treatment, conveyance and infrastructure improvements.

### 5.5.2 Factors Impacting Reliability

The Act requires a description of the reliability of the water supply and vulnerability to seasonal or climatic shortage. The following are some of the factors identified by Metropolitan and Mesa Water® that may have an impact on the reliability of Metropolitan supplies and local supplies.

#### 5.5.2.1 Legal

The addition of more species under the Endangered Species Act and new regulatory requirements could impact SWP operations by requiring additional export reductions, releases of additional water from storage or other operational changes impacting water supply operations.

#### 5.5.2.2 Water Quality

##### 5.5.2.2.1 Imported water

Metropolitan is responsible for providing high quality potable water throughout its service area. Over 300,000 water quality tests are performed per year on Metropolitan’s water to test for regulated contaminants and additional contaminants of concern to ensure the safety of its waters. Metropolitan’s supplies originate primarily from the CRA and from the SWP. A blend of these two sources, proportional to each year’s availability of the source, is then delivered throughout Metropolitan’s service area.

Metropolitan’s primary water sources face individual water quality issues of concern. The CRA water source contains higher total dissolved solids (TDS) and the SWP contains higher levels of organic matter, lending to the formation of disinfection byproducts. To remediate the CRA’s high level of salinity and the SWP’s high level of organic matter, Metropolitan blends CRA and SWP supplies and has upgraded all of its treatment facilities to include ozone treatment processes. In addition, Metropolitan has been engaged in efforts to protect its Colorado River supplies from threats of uranium, perchlorate, and chromium VI while also investigating the potential water quality impact of emerging contaminants, N-nitrosodimethylamine (NDMA), and pharmaceuticals and personal care products (PPCP). While unforeseeable water quality issues could alter reliability, Metropolitan’s current strategies ensure the deliverability of high quality water

The presence of Quagga Mussels in water sources is a water quality concern. Quagga Mussels are an invasive species that was first discovered in 2007 at Lake Mead, on the Colorado River. This species of mussels forms massive colonies in short periods of time, disrupting ecosystems and blocking water intakes. They are capable of causing significant disruption and damage to water distribution systems. Controlling the spread and impacts of this invasive species within the CRA requires extensive maintenance and results in reduced operational flexibility. It also resulted in Metropolitan eliminating deliveries of CRA water into Diamond Valley Lake (DVL) to keep the reservoir free from Quagga Mussels.

#### 5.5.2.2.2 Groundwater

OCWD is responsible for managing the OC Basin. To maintain groundwater quality, OCWD conducts an extensive monitoring program that serves to manage the OC Basin’s groundwater production, control groundwater contamination, and comply with all required laws and regulations. A network of nearly 700 wells provides OCWD a source for samples, which are tested for a variety of purposes. OCWD collects 600 to 1,700 samples each month to monitor Basin water quality. These samples are collected and tested according to approved federal and state procedures as well as industry-recognized quality assurance and control protocols.

Salinity is a significant water quality problem in many parts of southern California, including Orange County. Salinity is a measure of the dissolved minerals in water including both TDS and nitrates.

OCWD continuously monitors the levels of TDS in wells throughout the OC Basin. TDS currently has a California Secondary Maximum Contaminant Level (MCL) of 500 mg/L. The portions of the OC Basin with the highest levels are generally located in the Cities of Irvine, Tustin, Yorba Linda, Anaheim, and Fullerton. There is also a broad area in the central portion of the OC Basin where TDS ranges from 500 to 700 mg/L. Sources of TDS include the water supplies used to recharge the OC Basin and from onsite wastewater treatment systems, also known as septic systems. The TDS concentration in the OC Basin is expected to decrease over time as the TDS concentration of GWRS water used to recharge the OC Basin is approximately 50 mg/L.

Nitrates are one of the most common and widespread contaminants in groundwater supplies, originating from fertilizer use, animal feedlots, wastewater disposal systems, and other sources. The MCL for nitrate in drinking water is set at 10 mg/L. OCWD regularly monitors nitrate levels in groundwater and works with producers to treat wells that have exceeded safe levels of nitrate concentrations. OCWD manages the nitrate concentration of water recharged by its facilities to reduce nitrate concentrations in groundwater. This includes the operation of the Prado Wetlands, which was designed to remove nitrogen and other pollutants from the Santa Ana River before the water is diverted to be percolated into OCWD's surface water recharge system.

Although water from the Deep Aquifer System is of very high quality, it is amber-colored and contains a sulfuric odor due to buried natural organic material. These challenging aesthetic qualities require treatment before use as a source of drinking water. The total volume of the amber-colored groundwater is estimated to be approximately 1 MAF.

Other contaminants that OCWD monitors within the OC Basin include:

- Methyl Tertiary Butyl Ether (MTBE) – MTBE is an additive to gasoline that increases octane ratings but became a widespread contaminant in groundwater supplies. The greatest source of MTBE contamination comes from underground fuel tank releases. The primary MCL for MTBE in drinking water is 13 µg/L.
- Volatile Organic Compounds (VOC) – VOCs come from a variety of sources including industrial degreasers, paint thinners, and dry-cleaning solvents. Locations of VOC contamination within the OC Basin include the former El Toro marine Corps Air Station, the Shallow Aquifer System, and portions of the Principal Aquifer System in the Cities of Fullerton and Anaheim.
- NDMA – NDMA is a compound that can occur in wastewater that contains its precursors and is disinfected via chlorination and/or chloramination. It is also found in food products such as cured meat, fish, beer, milk, and tobacco smoke. The California Notification Level for NDMA is 10 ng/L and the Response Level is 300 ng/L. In the past, NDMA has been found in groundwater near the Talbert Barrier, which was traced to industrial wastewater dischargers.
- 1,4-Dioxane – 1,4-Dioxane is a suspected human carcinogen. It is used as a solvent in various industrial processes such as the manufacture of adhesive products and membranes.
- Perchlorate – Perchlorate enters groundwater through application of fertilizer containing perchlorate, water imported from the Colorado River, industrial or military sites that have perchlorate, and natural occurrence. Perchlorate was not detected in 84 percent of the 219 production wells tested between the years 2010 through 2014.
- Selenium – Selenium is a naturally occurring micronutrient found in soils and groundwater in the Newport Bay watershed. The bio-accumulation of selenium in the food chain may

result in deformities, stunted growth, reduced hatching success, and suppression of immune systems in fish and wildlife. Management of selenium is difficult as there is no off-the-shelf treatment technology available.

- Constituents of Emerging Concern (CEC) – CECs are either synthetic or naturally occurring substances that are not currently regulated in water supplies or wastewater discharged but can be detected using very sensitive analytical techniques. The newest group of CECs include PCPPs and endocrine disruptors. OCWD’s laboratory is one of a few in the state of California that continuously develops capabilities to analyze for new compounds (OCWD, Groundwater Management Plan 2015 Update, June 2015).

#### 5.5.2.3 Climate Change

Changing climate patterns are expected to shift precipitation patterns and affect water supply. Unpredictable weather patterns will make water supply planning more challenging. The areas of concern for California include a reduction in Sierra Nevada Mountain snowpack, increased intensity and frequency of extreme weather events, and rising sea levels causing increased risk of Delta levee failure, seawater intrusion of coastal groundwater basins, and potential cutbacks on the SWP and Central Valley Project (CVP). The major impact in California is that without additional surface storage, the earlier and heavier runoff (rather than snowpack retaining water in storage in the mountains), will result in more water being lost to the oceans. A heavy emphasis on storage is needed in the State of California.

In addition, the Colorado River Basin supplies have been inconsistent since about the year 2000, resulting in 13 of the last 16 years of the upper basin runoff being below normal. Climate models are predicting a continuation of this pattern whereby hotter and drier weather conditions will result in continuing lower runoff.

#### 5.5.3 Normal-Year Reliability Comparison

Although not projected to be used, Mesa Water® has entitlements to receive imported water from Metropolitan through MWDOC via connection to Metropolitan's regional distribution system. Pipeline and connection capacity rights do not guarantee the availability of water, per se, but they do guarantee the ability to convey water when it is available to the Metropolitan distribution system. All imported water supplies are assumed available to Mesa Water® from existing water transmission facilities. The demand and supplies listed below also include local groundwater supplies that are available to Mesa Water® through OCWD by a pre-determined pumping percentage. Mesa Water® is 100 percent reliable on groundwater for normal year demands from 2020 through 2040.

For the 2015 UWMP, the normal year was selected using a range from 1990 through 2014. Due to ongoing drought conditions within California and the increased implementation of mitigation measures, this historical range was determined to represent an average water demand for this UWMP. The water demand forecasting model developed for the Orange County Reliability Study (described in Section 4.4.1), to project the 25-year demand for Orange County water agencies,



also isolated the impacts that weather and future climate can have on water demand through the use of a statistical model. The explanatory variables of population, temperature, precipitation, unemployment rate, drought restrictions, and conservation measures were used to create the statistical model. The impacts of hot/dry weather condition are reflected as a percentage increase in water demands from the average condition. The average (normal) demand is represented by the average water demand of 1990 to 2014 (CDM Smith, Final Technical Memorandum #1 of Orange County Reliability Study, April 2016).

#### 5.5.4 Single-Dry Year Reliability Comparison

A single-dry year is defined as a single year of zero to minimal rainfall within a period that average precipitation is expected to occur. The water demand forecasting model developed for the Orange County Reliability Study (described in Section 4.4.1) isolated the impacts that weather and future climate can have on water demand through the use of a statistical model. The impacts of hot/dry weather condition are reflected as a percentage increase in water demands from the average condition (1990-2014). For a single dry year condition (FY2013-14), the model projects a six percent increase in demand for the OC Basin area where the Mesa Water® service area is located (CDM Smith, Final Technical Memorandum #1 of Orange County Reliability Study, April 2016). Detailed information of the model is included in Appendix G of 2015 Mesa Water® Urban Water Management Plan.

Mesa Water®'s metering data indicates that it is 100 percent reliable on groundwater for single dry year demands from 2020 through 2040 with a demand increase of six percent from normal demand with significant reserves held by Metropolitan, local groundwater supplies, and conservation.

#### 5.5.5 Multiple-Dry Year Reliability Comparison

Multiple-dry years are defined as three or more consecutive years with minimal rainfall within a period of average precipitation. The water demand forecasting model developed for the Orange County Reliability Study (described in Section 4.4.1) isolated the impacts that weather and future climate can have on water demand through the use of a statistical model. The impacts of hot/dry weather condition are reflected as a percentage increase in water demands from the average condition (1990-2014). For a single dry year condition (FY2013-14), the model projects a six percent increase in demand for the OC Basin area where the Mesa Water® service area is located (CDM Smith, Final Technical Memorandum #1 of Orange County Reliability Study, April 2016). It is conservatively assumed that a three-year multi dry year scenario is a repeat of the single dry year over three consecutive years (FY 2011-12 through FY 2013-14).

Mesa Water® is capable of meeting all customers' demands with significant reserves held by Metropolitan, local groundwater supplies, and conservation in multiple dry years from 2020 through 2040 with a demand increase of six percent from normal demand with significant reserves held by Metropolitan, local groundwater supplies, and conservation. The basis of the water year is displayed in Table 5-8.

Table 5-8: Basis of Water Year Data

Retail: Basis of Water Year Data			
Year Type	Base Year	Available Supplies if Year Type Repeats	
		<input type="checkbox"/>	Quantification of available supplies is not compatible with this table and is provided elsewhere in the UWMP Location
		<input checked="" type="checkbox"/>	Quantification of available supplies is provided in this table as either volume only, percent only, or both.
		Volume Available	% of Average Supply
Average Year	1990-2014		100%
Single-Dry Year	2014		106%
Multiple-Dry Years 1st Year	2012		106%
Multiple-Dry Years 2nd Year	2013		106%
Multiple-Dry Years 3rd Year	2014		106%
<b>NOTES:</b>			
[1] Developed by MWDOC as 2015 Bump Methodology			

Source: Mesa Water District 2015 UWMP Table 3-4

### 5.6 Supply and Demand Assessment

A comparison between the supply and the demand for projected years between 2010 and 2040 is shown in Tables 5-9 and 5-10. As stated above, the available supply will meet projected demand due to diversified supply and conservation measures

Table 5-9: Normal Year Supply and Demand Comparison (AF)

Retail: Normal Year Supply and Demand Comparison					
	2020	2025	2030	2035	2040
Supply totals	28,937	38,615	38,615	38,615	38,615
Demand totals	16,248	20,610	20,676	20,742	20,809
Excess Supply	12,689	18,005	17,939	17,873	17,806

A comparison between the supply and the demand in a single dry year is shown in Table 5-10. As stated above, the available supply will meet projected demand due to diversified supply and conservation measures.

Table 5-10: Dry Year Supply and Demand Comparison (AF)

Retail: Dry Year Supply and Demand Comparison					
	2020	2025	2030	2035	2040
Supply totals	28,937	38,615	38,615	38,615	38,615
Demand totals	21,847	21,917	21,987	22,058	22,126
Excess Supply	12,689	18,005	17,939	17,873	17,806

Source: Mesa Water District 2015 UWMP Table 3-6

A comparison between the supply and the demand in multiple dry years is shown in Table 5-11.

Table 5-11: Multiple Dry Years Supply and Demand Comparison (AF)

Retail: Multiple Dry Years Supply and Demand Comparison						
		2020	2025	2030	2035	2040
First Year	Supply Totals	28,937	38,615	38,615	38,615	38,615
	Demand Totals	21,847	21,917	21,987	22,058	22,126
	Excess Supply	12,689	18,005	17,939	17,873	17,806
Second Year	Supply Totals	28,937	38,615	38,615	38,615	38,615
	Excess Supply	21,847	21,917	21,987	22,058	22,126
	Difference	12,689	18,005	17,939	17,873	17,806
Third Year	Excess Supply	28,937	38,615	38,615	38,615	38,615
	Demand Totals	21,847	21,917	21,987	22,058	22,126
	Excess Supply	12,689	18,005	17,939	17,873	17,806

### 5.7 Water Shortage Contingency Plan

In connection to recent water supply challenges, the State Water Board found that California has been subject to multi-year droughts in the past, and the American Southwest is becoming drier, increasing the probability of prolonged droughts in the future. Due to current and potential future water supply shortages, Governor Brown issued a drought emergency proclamation in January 2014 and signed the 2014 Executive Order which directs urban water suppliers to implement drought response plans to limit outdoor irrigation and wasteful water practices if they are not already in place. Pursuant to California Water Code Section 106, it is the declared policy of the State that the use of water for domestic use is the highest use of water and that the next highest use is for irrigation. In southern California, the development of such policies has occurred at both the wholesale and retail level. This section describes the water supply shortage policies Metropolitan, MWDOC, and Mesa Water® have in place to respond to events including catastrophic interruption and up to a 50 percent reduction in water supply.

#### 5.7.1 Shortage Actions

##### 5.7.1.1 MWDOC Water Supply Allocation Plan

The Board of Directors adopted the Water Conservation and Water Supply Emergency Program, Ordinance No. 26, on May 14, 2015. Ordinance No. 26 establishes a comprehensive staged water conservation program that will encourage reduced water consumption within the Mesa Water® service area through conservation, enable effective water supply planning, assure reasonable and beneficial use of water, prevent waste of water, and maximize the efficient use of water within Mesa Water®. Along with permanent water conservation requirements, the Mesa Water® Comprehensive Water Conservation Program consists of the following three (3) stages found in Table 5-12 to respond to a reduction in potable water available to Mesa Water® for distribution to its customers with year round requirements in effect at all times unless a mandatory

conservation stage has been implemented by the Board of Directors (Mesa Water District, Ordinance No. 26, May 2015).

Table 5-12: Stages of Water Shortage Contingency Plan

Retail Stages of Water Shortage Contingency Plan		
Stage	Complete Both	
	Percent Supply Reduction <sup>[1]</sup>	Water Supply Condition
1	Up to 20%	A Level 1 Water Supply Shortage exists when Mesa Water® determines, in its sole discretion, a water supply shortage or threatened shortage exists, and a consumer demand reduction is necessary to make more efficient use of water and appropriately respond to existing water conditions.
2	Up to 30%	A Level 1 Water Supply Shortage exists when Mesa Water® determines, in its sole discretion, a water supply shortage or threatened shortage exists, and a consumer demand reduction is necessary to make more efficient use of water and appropriately respond to existing water conditions.
3	Up to 50%	A Level 3 Water Supply Shortage condition is also referred to as an "Emergency" condition. A Level 3 condition exists when Mesa Water® declares a water shortage emergency and notifies its residents and businesses that a significant reduction in consumer demand is necessary to maintain sufficient water supplies for public health and safety.
[1] One stage in the Water Shortage Contingency Plan must address a water shortage of 50%.		

Source: Mesa Water District 2015 UWMP Table 5-1

### 5.7.2 Three-Year Minimum Water Supply

As a matter of practice, Metropolitan does not provide annual estimates of the minimum supplies available to its member agencies. As such, Metropolitan member agencies must develop their own estimates for the purposes of meeting the requirements of the Act.

Section 135 of the Metropolitan Water District Act declares that a member agency has the right to invoke its “preferential right” to water, which grants each member agency a preferential right to purchase a percentage of Metropolitan’s available supplies based on specified, cumulative financial contributions to Metropolitan. Each year, Metropolitan calculates and distributes each member agency’s percentage of preferential rights. However, since Metropolitan’s creation in 1927, no member agency has ever invoked these rights as a means of acquiring limited supplies from Metropolitan.

As an alternative to invoking preferential rights, Metropolitan and its member agencies accepted the terms and conditions of Metropolitan’s shortage allocation plan, which allocated imported water under limited supply conditions. In fact, in FY 2015-2016, Metropolitan implemented its WSAP at a stage level 3 (seeking no greater than a 22.25 percent regional reduction of water use), which is the largest reduction Metropolitan has ever imposed on its member agencies. This WSAP level 3 reduction was determined when Metropolitan water supplies from the SWP was at its lowest levels ever delivered and water storage declined greater than 1 MAF in one year.

MWDOC has adopted a shortage allocation plan and accompanying allocation model that estimates firm demands on MWDOC. Assuming MWDOC would not be imposing mandatory restrictions if Metropolitan is not, the estimate of firm demands in MWDOC’s latest allocation model has been used to estimate the minimum imported supplies available to each of MWDOC’s retail agencies for 2015-2018. Thus, the estimate of the minimum imported supplies available to Mesa Water® is 18,526 AF, as a backup to its groundwater supplies as shown in Table 5-13 (MWDOC, Water Shortage Allocation Model, November 2015).

Table 5-13: Minimum Supply 2016-2018 (AF)

Retail: Minimum Supply 2016-2018			
	2016	2017	2018
Available Water Supply	18,526	18,526	18,526

Source: Mesa Water District 2015 UWMP Table 5-2

### 5.7.3 Catastrophic Supply Interruption

#### 5.7.3.1 Metropolitan

Metropolitan has comprehensive plans for stages of actions it would undertake to address a catastrophic interruption in water supplies through its WSDM Plan and WSAP. Metropolitan also developed an Emergency Storage Requirement to mitigate against potential interruption in water supplies resulting from catastrophic occurrences within the southern California region, including seismic events along the San Andreas Fault. In addition, Metropolitan is working with the state to implement a comprehensive improvement plan to address catastrophic occurrences outside of the southern California region, such as a maximum probable seismic event in the Delta that would cause levee failure and disruption of SWP deliveries. For greater detail on Metropolitan’s planned responses to catastrophic interruption, please refer to Metropolitan’s 2015 UWMP.

#### 5.7.3.2 Mesa Water District Water Shortage Emergency Response

In 1991, in accordance with the requirements of Assembly Bill IIX, Mesa Water® developed a comprehensive water shortage contingency plan as an amendment to the 1990 UWMP. The plan included all of the information necessary to meet the requirements of subdivision (e) of California Water Code Section 10631.

Public meetings and the availability of copies of the draft Water Shortage Contingency Plan were properly noticed in the local newspaper and were available for public review.

In addition to droughts, earthquakes, hazardous material spills or leaks, severe storms or floods, and widespread power outages can cause water supply shortages. Mesa Water® keeps abreast of water supply situations and has always taken a proactive approach in responding to water shortages. It is Mesa Water®'s policy to inform customers of current and projected water supply situations long before Mesa Water®, or its suppliers, declare water shortages.

5.7.4 Prohibitions, Penalties and Consumption Reduction Method

5.7.4.1 Mesa Water District Water Shortage Emergency Response

The Water Conservation Ordinance No. 26 lists water conservation requirements which shall take effect upon implementation by the Board of Directors. These prohibitions shall promote the efficient use of water, reduce or eliminate water waste, complement the Mesa Water® Water Quality regulations and urban runoff reduction efforts, and enable implementation of the Mesa Water® Water Shortage Contingency Measures. A list of Mesa Water®'s prohibitions can be found in Table 5-14.

Table 5-14: Restrictions and Prohibitions on End Uses

Retail Only: Restrictions and Prohibitions on End Uses			
Stage	Restrictions and Prohibitions on End Users	Additional Explanation or Reference	Penalty, Charge, or Other Enforcement?
Permanent Year-Round	Landscape - Limit landscape irrigation to specific times	Watering or irrigating of lawn, landscape, or other vegetated area with potable water is prohibited between the hours of 8:00 a.m. and 5:00 p.m. Pacific Standard Time on any day. Hand-held watering cans, buckets, or similar containers reasonably used to convey water for irrigation purposes are not subject to these time restrictions. Similarly, a hand-held hose equipped with a fully functioning, positive self-closing water shut-off nozzle or device may be used during the otherwise restricted period. If necessary, and for very short periods of time for the express purpose of adjusting or repairing it, one may operate an irrigation system during the otherwise restricted period.	No
Permanent Year-Round	Landscape - Restrict or prohibit runoff from landscape irrigation	-	No

Retail Only: Restrictions and Prohibitions on End Uses			
Stage	Restrictions and Prohibitions on End Users	Additional Explanation or Reference	Penalty, Charge, or Other Enforcement?
Permanent Year-Round	Other - Prohibit use of potable water for washing hard surfaces	This restriction does not apply in situations necessary to alleviate safety or sanitary hazards, and then only by use of a hand-held bucket or similar container, a handheld hose equipped with a fully functioning, positive self-closing water shut-off device, a low-volume, high-pressure cleaning machine equipped to recycle any water used, or a low-volume high pressure water broom.	No
Permanent Year-Round	Other - Customers must repair leaks, breaks, and malfunctions in a timely manner	All leaks, breaks, and other malfunctions must be corrected in no more than seven (7) days of receiving notice from Water Mesa®.	No
Permanent Year-Round	Water Features - Restrict water use for decorative water features, such as fountains	Operating a water fountain or other decorative water feature that does not use recirculated water is prohibited.	No
Permanent Year-Round	Other - Prohibit vehicle washing except at facilities using recycled or recirculating water	-	No
Permanent Year-Round	CII - Restaurants may only serve water upon request	-	No
Permanent Year-Round	CII - Lodging establishment must offer opt out of linen service	-	No
Permanent Year-Round	Other	Installation of single pass cooling systems is prohibited in buildings requesting new water service from Mesa Water®.	No
Permanent Year-Round	Other	Installation of non-recirculating water systems is prohibited in new commercial conveyor car wash and new commercial laundry systems.	No
Permanent Year-Round	CII - Commercial kitchens required to use pre-rinse spray valves	-	No

<b>Retail Only: Restrictions and Prohibitions on End Uses</b>			
<b>Stage</b>	<b>Restrictions and Prohibitions on End Users</b>	<b>Additional Explanation or Reference</b>	<b>Penalty, Charge, or Other Enforcement?</b>
Permanent Year-Round	Other	All commercial conveyor car wash systems must use re-circulating water systems or must secure a waiver of this requirement from Mesa Water®.	No
1	Landscape - Limit landscape irrigation to specific days	Watering or irrigating of lawn, landscape, or other vegetated area is limited up to a maximum of three (3) days per week on a schedule established and posted by Mesa Water®. This provision does not apply to watering or irrigating by use of a handheld bucket or similar container, a hand-held hose equipped with a positive self-closing water shut-off nozzle or device, or for very short periods of time for the express purpose of adjusting or repairing an irrigation system, and then only while under the supervision of a competent person.	Yes
1	Other - Customers must repair leaks, breaks, and malfunctions in a timely manner	All leaks, breaks, and other malfunctions must be corrected in no more than seventy-two (72) hours of receiving notice from Water Mesa®.	Yes
1	Landscape - Other landscape restriction or prohibition	Irrigation is prohibited during rain events	Yes
2	Landscape - Limit landscape irrigation to specific days	Watering or irrigating of lawn, landscape, or other vegetated area is limited up to a maximum of two (2) days per week on a schedule established and posted by Mesa Water®. This provision does not apply to watering or irrigating by use of a handheld bucket or similar container, a hand-held hose equipped with a positive self-closing water shut-off nozzle or device, or for very short periods of time for the express purpose of adjusting or repairing an irrigation system, and then only while under the supervision of a competent person.	Yes
2	Other - Customers must repair leaks, breaks, and malfunctions in a timely manner	All leaks, breaks, and other malfunctions must be corrected in no more than forty-eight (48) hours of receiving notice from Water Mesa®.	Yes



Retail Only: Restrictions and Prohibitions on End Uses			
Stage	Restrictions and Prohibitions on End Users	Additional Explanation or Reference	Penalty, Charge, or Other Enforcement?
2	Other water feature or swimming pool restriction	Filling or refilling ornamental fountains, lakes, and ponds is prohibited, except to the extent needed to sustain aquatic life, provided that such animals have been actively managed within the water feature prior to declaration of a supply shortage level.	Yes
3	Other - Customers must repair leaks, breaks, and malfunctions in a timely manner	All leaks, breaks, and other malfunctions must be corrected in no more than twenty-four (24) hours of receiving notice from Water Mesa®.	Yes
3	Other - Prohibit vehicle washing except at facilities using recycled or recirculating water	-	Yes
3	Other water feature or swimming pool restriction	Filling and refilling of residential swimming pools or outdoor spas with water is prohibited.	Yes
3	Other	No new potable water service, new temporary meters, and statement of immediate ability to serve or provide water service will be issued except under the following circumstances: 1) a valid, unexpired building permit has been issued for the project, 2) the project is necessary to protect the public health, safety, and welfare, or the applicant provides substantial evidence of an enforceable commitment that water demand for the project will be offset prior to the provision of a new water meter(s) to the satisfaction of Mesa Water®.	Yes

Source: Mesa Water District 2015 UWMP Table 5-3

5.7.4.2 Penalties

Any customer who violates provisions of the Water Conservation Program by either excess use of water or by specific violation of one or more of the applicable water use restrictions for a particular mandatory conservation stage may be cited by Mesa Water® and subject to written notices, surcharges, fines, flow restrictions, and/or service termination.

The first and second violations will result in a written warning issued by Mesa Water®. During effective periods of Level 1, Level 2, and Level 3-Water Supply Shortages, the third violation will result in a written violation along with a conservation fee of one hundred dollars (\$100). A fourth and any subsequent violation will receive in a written warning along with a conservation fee of

(\$200). In addition to any fines, Mesa Water® may install a flow restricting device and/or disconnect a customer's water service for a willful violation of mandatory restrictions (Mesa Water District, Ordinance No. 26, May 2015).

5.7.4.3 Consumption Reduction Methods

Table 5-14 lists the consumption reduction methods that will be used to reduce water use in restrictive stages.

Table 5-15: Stages of Water Shortage Contingency Plan - Consumption Reduction Methods

Retail Only: Stages of Water Shortage Contingency Plan - Consumption Reduction Methods		
Stage	Consumption Reduction Methods by Water Supplier	Additional Explanation or Reference
1	Other	Stage 1 Water Conservation Measures
2	Other	Stage 2 Water Conservation Measures
3	Other	Stage 3 Water Conservation Measures

Source: Mesa Water District 2015 UWMP Table 5-4

5.7.5 Reduction Measuring Mechanism

Mesa Water®’s system is monitored by a modern computer-based Supervisory Control and Data Acquisition (SCADA) system. This system allows Mesa Water® staff to monitor the status and control all elements of the Mesa Water® system from one central and various remote locations. The SCADA system continuously records data and printed reports of system conditions can be generated on demand.

All customer-billing records are maintained on a SQL database system using Cogsdale Customer Information Software. Mesa Water®’s customer information and billing software has the capability to generate usage reports in formats necessary to monitor customer usage.

MWDOC will provide each member agency with monthly water use reports that will compare each member agency’s current cumulative retail usage to their allocation baseline from Metropolitan. MWDOC will also provide quarterly reports on its cumulative retail usage versus its allocation baseline.

## 6.0 CONCLUSION

Mesa Water District optimizes its water resource supply through an integrated resource approach, utilizing available water programs and projects. Mesa Water® receives its water from groundwater, imported water.

The WSA includes a discussion of the Senate Bill 610 legislation, an overview of the One Metro West, and analysis of water demands for Mesa Water®'s existing service the proposed changes to Mesa Water® development projects over the UWMP planning horizon. The WSA also includes an analysis of reliability of Mesa Water®'s water supplies and water quality and concludes with a sufficiency analysis of water supply during normal, single-dry, and multiple dry years for the next 20 years and build out.

**The WSA does not evaluate the adequacy of the Mesa Water®'s infrastructure to handle the available water supplies nor does it make any recommendations with respect to capital improvements that may be necessary in order to provide an adequate level of service to the proposed development projects.**

This WSA identifies a program of options to provide sufficient water supply for One Metro West over a 20-year planning period as well as build out.

The proposed One Metro West includes changes to the land use of the existing 16.2 acre site from industrial to a mixed use development which includes residential, commercial, and office land use. The change in land use results in a net increase of the maximum day demands by 277,523 gpd, or 310.88 AFY.

Mesa Water® obtains water from the local groundwater sources produced by District wells, and if needed, imported water via Metropolitan Water District. Mesa Water® currently relies and will continue to rely solely on own groundwater wells.

The information included in this Water Supply Assessment identifies programs and activities that collectively represent reasonable opportunities to ensure an adequate supply of water for Mesa Water®, inclusive of the subject Project, now and into the future.

Mesa Water® can provide an adequate supply of water and has opportunities to increase water resources by the following methods. First, Mesa Water® has the capability of utilizing additional groundwater capacity from the existing wells. Second, water conservation efforts and regulations can provide additional water resources.



*Dedicated to  
Satisfying our Community's  
Water Needs*

## MEMORANDUM

TO: Engineering and Operations Committee  
FROM: Paul E. Shoenberger, P.E., General Manager  
DATE: October 15, 2019  
SUBJECT: City of Costa Mesa Application for the California Emergency Solutions and Housing Program

---

### RECOMMENDATION

Direct staff to sign a letter of support for the City of Costa Mesa's Application for the California Emergency Solutions and Housing Program.

### STRATEGIC PLAN

Goal #4: Increase public awareness about Mesa Water and about water.  
Goal #6: Provide outstanding customer service.  
Goal #7: Actively participate in regional water issues.

### PRIOR BOARD ACTION/DISCUSSION

None.

### DISCUSSION

On Wednesday, October 9, 2019, the City of Costa Mesa (City) reached out to Mesa Water District (Mesa Water®) requesting support for the City's California Emergency Solutions and Housing (CESH) Program Round One Funding Application.

CESH funds may be used for five primary activities: housing relocation and stabilization services (including rental assistance), operating subsidies for permanent housing, flexible housing subsidy funds, operating support for emergency housing interventions, and systems support for homelessness services and housing delivery systems.

City Manager Lori Ann Farrell Harrison writes via email, "By signing and sending the attached letter to Supervisor Steel, your support will help Costa Mesa's application for its homeless shelter and homeless services operation, bringing vital resources to the Central Service Planning Area (SPA)".

The Orange County Board of Supervisors are scheduled to hear this topic at their meeting on October 22, 2019 at 9 a.m.; the City will pick up any approved support letters on October 16, 2019 and hand deliver them to Michelle Steel, Vice Chair of the OC Board of Supervisors for consideration.

Staff recommends that the Board direct staff to sign a letter of support for the City of Costa Mesa's Application for the California Emergency Solutions and Housing Program.

### FINANCIAL IMPACT

None.

### ATTACHMENTS

Attachment A: Draft Letter



*Dedicated to  
Satisfying our Community's  
Water Needs*

---

#### BOARD OF DIRECTORS

**Shawn Dewane**  
*President  
Division V*

**Marice H. DePasquale**  
*Vice President  
Division III*

**Jim Atkinson**  
*Director  
Division IV*

**Fred R. Bockmiller, P.E.**  
*Director  
Division I*

**James R. Fisler**  
*Director  
Division II*

**Paul E. Shoenberger, P.E.**  
*General Manager*

**Denise Garcia**  
*District Secretary*

**Marwan Khalifa, CPA, MBA**  
*District Treasurer*

**Atkinson, Andelson,  
Loya, Ruud & Romo**  
*Legal Counsel*

---

1965 Placentia Avenue  
Costa Mesa, CA 92627  
tel 949.631.1200  
fax 949.574.1036  
info@MesaWater.org  
**MesaWater.org**

October 15, 2019

Michelle Steel, Vice Chair  
Orange County Board of Supervisors  
333 W. Santa Ana Boulevard  
Santa Ana, CA 92701

**Subject: City of Costa Mesa Application for the California Emergency Solutions and Housing (CESH) Program**

Dear Supervisor Steel,

On behalf of Mesa Water District, I am writing to express my support for the City of Costa Mesa's application for the California Emergency Solutions and Housing (CESH) Program round one funding. As a regional and community partner with the City, I believe Orange County's vulnerable homeless population in the Central Service Planning Area (SPA) would benefit from the City's CESH proposal.

As you know, CESH is a statewide program that was created to provide funding for cities and non-profits that assist individuals experiencing or at risk of homelessness. The Continuum of Care (CoC), the entity responsible for CESH in Orange County, was awarded approximately \$1.9 million in funds to be granted out to eligible applicants. However, neither the City, nor any applicant in the Central SPA, was recommended for funding at the June 26 CoC Board of Directors Meeting. The Board of Supervisors are now responsible for considering the funding recommendations of the CoC.

Mesa Water District partners with and supports the City of Costa Mesa's ongoing efforts to combat homelessness. In April 2019, the City began operating its 50-bed bridge shelter in collaboration with Mercy House. This temporary shelter provides wrap-around services, housing referrals, comprehensive case management, and transportation for both homeless Costa Mesa residents and non-residents. The City also recently purchased property to provide a permanent homeless shelter, formed a local task force to refer homeless individuals to social services, and developed an information center to help street outreach staff more efficiently identify homeless individuals. CESH funding would complement these efforts and further address the regional homeless crisis at the city level.

In conclusion, Mesa Water District respectfully requests your support for Costa Mesa's CESH application, which would allow the City to better serve Orange County's homeless individuals and continue its work towards a regional long-term solution to homelessness.

Sincerely,

Paul E. Shoenberger, P.E.  
General Manager  
Mesa Water District

c: Orange County Board of Supervisors

**REPORTS:**

8. REPORT OF THE GENERAL MANAGER

**REPORTS:**

9. DIRECTORS' REPORTS AND COMMENTS



*Dedicated to  
Satisfying our Community's  
Water Needs*

## MEMORANDUM

TO: Engineering and Operations Committee  
FROM: Phil Lauri, P.E., Assistant General Manager  
DATE: October 15, 2019  
SUBJECT: Reservoirs 1 & 2 Chemical Management System

---

### RECOMMENDATION

This item is provided for information.

### STRATEGIC PLAN

Goal #1: Provide a safe, abundant, and reliable water supply.  
Goal #2: Practice perpetual infrastructure renewal and improvement.  
Goal #6: Provide outstanding customer service.

### PRIOR BOARD ACTIONS

At its January 20, 2015 meeting, the Engineering and Operations (E&O) Committee received an information item that staff was developing Request for Proposals for Reservoir Pump Inspection and Efficiency Testing.

At its September 10, 2015 meeting, the Board of Directors (Board) awarded a contract to Hazen and Sawyer for a not to exceed amount of \$418,018 to provide Professional Engineering Services for the Reservoirs 1 & 2 Pumps, Controls, and Chemical System Assessment Project.

At its February 18, 2018 meeting, the Board awarded a contract to Hazen and Sawyer for \$262,835 plus a contingency for a total not to exceed amount of \$289,119 for Professional Engineering Design Services for the completion of the Reservoirs 1 & 2 Chemical Management System Design Project.

### BACKGROUND

Mesa Water District (Mesa Water®) has two storage reservoirs that pump water into the distribution system. Reservoir No. 1, constructed in 1990, has a capacity of 10 million gallons. Reservoir No. 2, constructed in 1996, has a capacity of 18 million gallons. Both reservoirs have two operation modes - fill or empty. Surplus water enters and exits the reservoirs in a common inlet and outlet pipeline. Water quality samples are collected during filling and emptying of the reservoirs. Since entering into service over twenty years ago, the operating conditions have changed. When the reservoirs went into service, water entering the reservoirs from groundwater production wells or imported from Metropolitan Water District of Southern California used free chlorine as a disinfectant.

Currently, water entering the reservoirs from all sources of supply uses a combination of chlorine and ammonia for chloramination disinfection. The ammonia is a precursor to nitrification in the reservoirs. A thorough Nitrification Study was performed in 2016 by Carollo Engineers, Inc., to evaluate the causes of nitrification and to recommend capital and operational improvements. The high-priority recommendations from the Nitrification Study included adding a real-time chemical management system to the reservoirs.





DISCUSSION

As part of the Reservoir Nos. 1 & 2 Pumps, Controls, and Chemical System Assessment Project performed in 2016, Hazen and Sawyer evaluated the reservoir chemical injection and mixing system. The assessment included a recommendation to real-time chemical management systems to replace the Solar Bees with more turbulent mixers in both reservoirs to achieve ubiquitous mixing, real-time water quality feedback, and automatic control. The Preliminary Design Report (PDR) for the Chemical Dosing System and Water Quality Monitoring was developed to provide a roadmap for implementation of this recommendation. The PDR noted that a well-mixed reservoir should have minimal dead space and uniform water quality, and should not have stratification. The Solar Bee mixers currently installed in Reservoir Nos. 1 and 2 provide challenges to obtain adequate mixing to manage and control nitrification events or prevent stratification under a chloramine disinfection regiment. Uniform reservoir mixing can be achieved if reservoirs are equipped with mixers that have the ability to uniformly disperse chlorine and ammonia to achieve a stable chlorine residual, minimize dead space, and prevent stratification.

Per the Board’s request, the original PDR is provided in Attachment A and includes the background and need for a more robust chemical management system.

FINANCIAL IMPACT

In Fiscal Year 2020, no funds are budgeted for Reservoir Chemical Management Design.

	<b>Reservoir Chemical Management Design</b>	
	Project Estimate <u>Amounts</u>	Project Cost <u>Amounts</u>
Initial Project Estimate (FY 2018)	\$ 200,000	
Original Contracts		\$ 262,835
Change Orders		<u>0</u>
Requested Funding		0
Revised Contracts		<u>\$262,835</u>
Actual spent to date (10/2/2019)		\$210,914
Revised Project Estimate	\$ 262,835	

ATTACHMENTS

Attachment A: Preliminary Design Report: Chemical Dosing System and Water Quality Monitoring



**Reservoir 1 & 2 Pumps, Controls, and Chemical System Assessment Project**

# **Preliminary Design Report**

## **Chemical Dosing System and Water Quality Monitoring**

December, 2017



**MesaWater**  
DISTRICT®





Hazen and Sawyer  
7700 Irvine Center Drive, Suite 200  
Irvine, CA 92618 • 949.557.8549

## Reservoirs 1 & 2 Pumps, Controls, and Chemical System Assessment Project

# Preliminary Design Report Chemical Dosing System and Water Quality Monitoring

Prepared for



December 2017

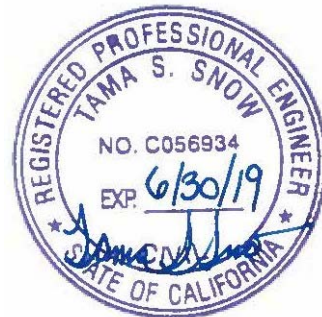

[This page is intentionally left blank.]



## **Table of Contents**

Executive Summary .....	1
1. Introduction .....	4
1.1 Project Background .....	4
1.2 Purpose .....	6
2. Existing Reservoir Operation and Water Quality .....	6
2.1 Existing Reservoir Operation .....	6
2.2 Nitrification Chemistry .....	7
2.3 Reservoir Water Quality .....	9
2.3.1 Reservoir Effluent .....	9
2.3.2 Reservoirs Response plan .....	15
2.4 Nitrification Mitigation and Reservoir Operational Improvements .....	16
2.4.1 Chemical Feed and Water Quality Monitoring .....	16
2.4.2 Reservoir Mixer System Improvements .....	16
2.4.3 Ammonia Feed Installation at the Reservoirs .....	17
2.4.4 Full Reservoir Cleaning and Breakpoint Chlorination .....	17
3. Chemical Injection System .....	17
3.1 Existing Chemical Injection System and Chemical Storage .....	17
3.2 Proposed Chemical Storage and Feed System .....	19
3.2.1 Design Criteria .....	19
3.2.1.1 Sodium Hypochlorite Storage Concerns .....	22
3.2.1.2 Chemical Storage Design Summary .....	23
3.2.1.3 Reservoir 1 .....	24
3.2.1.4 Reservoir 2 .....	24
3.2.2 Feed Pumps .....	25
3.2.3 Chemical Feed Recommendations .....	25
3.2.3.1 Integrated Sodium Hypochlorite Feed System and Tank .....	25
3.2.3.2 Integrated Ammonia Feed System and Tank .....	26

[This page is intentionally left blank.]

3.3	Reservoir Management Systems .....	27
3.3.1	Vortex RMS by Superior Water .....	28
3.3.2	PAX .....	28
3.3.3	Tank Shark by UGSI Solutions .....	29
<b>4.</b>	<b>Site Development .....</b>	<b>34</b>
4.1	Existing Site Layouts .....	34
4.1.1	Reservoir 1 .....	34
4.1.2	Reservoir 2 .....	35
4.2	Proposed Improvements .....	35
4.2.1	Reservoir 1 .....	36
4.2.2	Reservoir 2 .....	38
<b>5.</b>	<b>Electrical, Instrumentation and Controls.....</b>	<b>39</b>
5.1	Electrical .....	39
5.1.1	Reservoir 1 .....	39
5.1.2	Reservoir 2 .....	40
5.2	SCADA .....	40
<b>6.</b>	<b>Construction Issues, Permits, Schedules and Construction Documentation.....</b>	<b>40</b>
6.1	List of Permits and Requirements .....	40
6.2	Recommendations for Construction Phasing and Schedule .....	41
6.3	Drawing List.....	41
6.4	Specifications List.....	43
6.5	Opinion of Probable Construction Costs .....	47
<b>7.</b>	<b>Recommendations.....</b>	<b>48</b>



[This page is intentionally left blank.]

## **List of Tables**

Table ES 1-1. Summary Recommended Improvements to Chemical Storage and Feed Systems .	3
Table 2-1. Reservoir Water Quality from November 2014 to November 2015 .....	10
Table 3-1. Summary Reservoir Characteristics and Existing Chemical Feed Systems.....	18
Table 3-2. Chemical Feed Design Criteria .....	20
Table 3-3. Chemical Storage Requirements with Incoming Residual .....	20
Table 3-4. Chemical Storage Requirements with Zero Incoming Residual .....	21
Table 3-5. Reservoir 1 Storage Design Summary .....	24
Table 3-6. Reservoir 2 Storage Design Summary .....	24
Table 3-7. Chemical Feed Pump Type Comparison.....	25
Table 3-8. Summary Reservoir Mixing Systems Evaluated.....	30
Table 3-9. Reservoir Mixing Systems Comparison.....	31
Table 6-1. Permit Requirements Summary.....	41
Table 6-2. Construction Drawing List .....	42
Table 6-3. Construction Specification List .....	43
Table 6-4. Engineer's Estimate of Probable Construction Costs – Reservoir 1 .....	47
Table 6-5. Engineer's Estimate of Probable Construction Costs – Reservoir 2.....	48
Table 7-1. Recommended Chemical Storage and Feed Equipment Improvements .....	49

## **List of Figures**

Figure ES 1-1. Reservoir 1 Site Layout.....	1
Figure ES 1-2. Reservoir 2 Site Layout .....	2
Figure 1-1. Reservoir 1 Site Location Map .....	5
Figure 1-2. Reservoir 2 Site Location Map .....	5
Figure 2-1. Reservoir 2 Common Inlet and Outlet Pipe .....	7
Figure 2-2. Breakpoint Chlorination Chart.....	8
Figure 2-3. Reservoir 1 Water Quality Analyzer.....	9
Figure 2-4. Reservoir 2 Water Quality Sampling Location.....	9
Figure 2-5. Nitrite Concentration in Reservoirs 1 and 2 from November 2014 to November 2015 .....	11
Figure 2-6. Water Temperature in Reservoir 1 November 2014 to November 2015 .....	12
Figure 2-7. Water Temperature in Reservoir 2 November 2014 to November 2015 .....	12
Figure 2-8. Water pH in Reservoir 1 November 2014 to November 2015.....	13
Figure 2-9. Water pH in Reservoir 2 November 2014 to November 2015.....	13
Figure 2-10. Total Chlorine Residual in Reservoir 1 November 2014 to November 2015.....	14
Figure 2-11. Total Chlorine in Reservoir 2 November 2014 to November 2015.....	15
Figure 2-12. Decision Tree for Nitrification Action Levels .....	15
Figure 3-1. Reservoir 1 Layout and Flow Direction.....	18
Figure 3-2. Reservoir 2 Layout.....	19
Figure 3-3. Sodium Hypochlorite Decay Curves (AWWA Hypochlorite Assessment Model) ...	22
Figure 3-4. Chlorate Concentration as a Function of Chemical Storage, Dosing at 2.5 mg/L Cl <sub>2</sub> .....	23

[This page is intentionally left blank.]

Figure 3-5. Chlorate Concentration as a Function of Chemical Storage, Dosing at 1 mg/L Cl <sub>2</sub> .	23
Figure 3-6. Sample Sodium Hypochlorite Skid.....	26
Figure 3-7. Sample High-Density Crosslinked Polyethylene (XLPE) Tank .....	27
Figure 3-8. Vortex Mixer Reservoir Installation .....	28
Figure 3-9. PAX Mixer Installation.....	29
Figure 3-10. Tank Shark Installation .....	30
Figure 3-11. Reservoir 1 Proposed PAX Mixing System Layout .....	32
Figure 3-12. Reservoir 1 Proposed Tank Shark Mixing System Layout.....	33
Figure 3-13. Reservoir 2 Proposed PAX Mixing System Layout .....	33
Figure 3-14. Reservoir 2 Proposed Tank Shark Mixing System Layout.....	34
Figure 4-1. Reservoir 1 Site Layout of Proposed Chemical Feed Facility .....	37

## **List of Appendices**

Appendix A - Reservoir Mixing Systems
Appendix B - Chemical Feed System and Mixing System P&ID
Appendix C - 30 % Construction Drawings
Appendix D - Engineers Estimates of Probable Costs
Appendix E - AWWA Journal Article

[This page is intentionally left blank.]

## List of Acronyms

<b>Abbreviation</b>	<b>Definition</b>
AACE	American Association of Cost Engineering
AOB	Ammonia Oxidizing Bacteria
CFS	Cubic Feet per Second
CFU	Colony Forming Units
ft	Feet
gpm	Gallons per Minute
HMI	Human-Machine Interface
HPC	Heterotrophic Plate Counts
MCL	Maximum Contaminant Level
MG	Million Gallons
MGD	Million Gallons per Day
MWRF	Mesa Water Reliability Facility
NaOCL	Sodium Hypochlorite
NH <sub>4</sub> OH	Ammonia
NO <sub>2</sub> -N	Nitrite
PDR	Preliminary Design Report
RMS	Reservoir Management System
SCADA	Supervisory Control and Data Acquisition
SOP	Standard Operating Procedure
TDS	Total Dissolved Solids
WTP	Water Treatment Plant

[This page is intentionally left blank.]

## Executive Summary

Mesa Water® District (Mesa Water®) supplies potable water to over 110,000 residents in an 18-square mile area, serving Costa Mesa, parts of Newport Beach and unincorporated areas of Orange County. Mesa Water® currently meets its potable water demand from five active clear wells and the Mesa Water Reliability Facility (MWRF) that treats the deep aquifer amber colored water. Water from the clear wells and the MWRF Facility is pumped directly into the potable water distribution system. Surplus water is delivered to the storage reservoirs, Mesa Water Reservoirs 1 and 2. Reservoir storage augments potable water supplies when water demands exceed the production of the five (5) clear wells and the MWRF.

Mesa Water® uses chloramine as the primary disinfectant at the well sites and the MWRF facility. On average, the surplus water carries a chloramine residual of 1.5 mg/L when it enters the reservoirs. Each reservoir is currently equipped with a chlorine, 12.5% (by weight) sodium hypochlorite chemical feed system to boost the residual by converting free ammonia to chloramine. However, despite the addition of sodium hypochlorite, water quality in the existing Reservoirs 1 and 2 has experienced degradation due to nitrification. The nitrification is primarily due to a loss of chlorine residual, excess free ammonia and water age within the existing reservoirs and distribution system.

To address nitrification issues being experienced within the existing reservoirs and distribution system, Mesa Water® retained Hazen and Sawyer and Richard Brady and Associates to complete an evaluation of the existing reservoir mixing system, reservoir chemical feed system and controls at Mesa Water®'s Reservoirs 1 and 2, shown in Figure ES 1-1 and Figure ES 1-2, respectively and make recommendations for improvements.



Figure ES 1-1. Reservoir 1 Site Layout





**Figure ES 1-2. Reservoir 2 Site Layout**

Reservoir 1 has a capacity of 10 MG and Reservoir 2 has a capacity of 18 MG. They both operate in two modes, fill or empty. Surplus water enters and exits the reservoir in a common inlet and outlet pipeline. Water quality samples are collected during filling and emptying of the reservoir as well as when the water is idle in the reservoir via the common inlet and outlet pipelines. Sodium hypochlorite 12.5% (by weight) is manually dosed through two existing SolarBee mixers at Reservoir 1 and one SolarBee mixer at Reservoir 2 until sampling shows the target residual concentration has been reached. Water quality data from 2015 for Reservoirs 1 and 2 provided by Mesa Water, indicates that nitrification is occurring and there are large fluctuations in the residual concentrations at both reservoirs (0.22 to 2.8 mg/L and 0.44 to 2.6 mg/L) in Reservoirs 1 and 2 respectively. In addition, the water quality information showed that the total ammonia concentration in the reservoirs were linearly proportional to total chlorine and the low total ammonia concentration corresponded to the low chlorine residual.

To minimize the large swings in the residuals and maintain a consistent total chlorine residual of 2.5 mg/L in the reservoirs, it is recommended that the two existing reservoirs, Reservoirs 1 and 2 be retrofitted with chemical feed and monitoring equipment that have the capabilities to ensure that the potable water quality standards are being met at each of the reservoir sites. Equipment shall include chemical storage tanks that will provide approximately one-month supply of 19% (by weight) aqueous ammonia (ammonia) and 12.5% (by weight) sodium hypochlorite, metering pumps, chemical injection equipment, in-tank mixing systems and residual disinfection analyzers that provide direct and consistent monitoring capabilities.

To be consistent with Mesa Water's Well Automation Project and for the ease of maintenance and operations, the following modifications are recommended to the Reservoirs 1 and 2 existing chemical storage, feed and mixing systems as summarized in Table ES 1-1.

**Table ES 1-1. Summary Recommended Improvements to Chemical Storage and Feed Systems**

Equipment	Reservoir 1	Reservoir 2
<b>Chemical Feed System – Sodium Hypochlorite</b>		
- Tank Size <sup>1</sup>	500 gallon fiberglass tank	900 gallon fiberglass tank
- Metering Pump	Diaphragm Metering Pump <sup>2</sup> (2 duty + 2 standby)	Diaphragm Metering Pump <sup>3</sup> (1 duty + 1 standby)
- Feed Rate	8 gph with 100:1 turndown	15 gph with 100:1 turndown
<b>Chemical Feed System – Ammonia</b>		
- Tank Size	100 gallons XLPE or HDLPE Tank	200 gallons XLPE or HDLPE Tank
- Metering Pump	Diaphragm Metering Pump (1 duty + 1 standby)	Diaphragm Metering Pump (1 duty + 1 standby)
- Feed Rate	3 gph with 10:1 turndown	3 gph with 10:1 turndown
<b>Mixers</b>		
- Model/ Number of Mixers	Tank Shark RMS / 2	Tank Shark RMS / 4
<b>Electrical</b>	Power from Distribution Panel “DF”	Power from Distribution Panel “PE”
<b>SCADA</b>	New equipment is integrated into existing RTU-30	New equipment is integrated into existing RTU-32

<sup>1</sup> Tank sizes for consistency with Well Automation Project at Mesa Water’s request. Final sizes will be reevaluated based on analysis of perchlorate formation at Well no. 7.

<sup>2</sup> Based on Maximum in flow of 7000 gpm. Increase residual from 1.5 mg/L to 2.5 mg/L with ability to dose at 2.5 mg/L

<sup>3</sup> Based on Maximum in flow of 11,600 gpm. Increase residual from 1.5 mg/L to 2.5 mg/L with ability to dose at 2.5 mg/L

The chemical storage tanks have been sized to be consistent with Mesa Water’s Well Automation Project. It is suggested that testing for perchlorate formation in the sodium hypochlorite storage tank at Mesa Water’s Well No. 7 site be conducted and the chemical storage tanks at the Reservoirs 1 and 2 sites be sized accordingly during final design to minimize chemical storage longer than 30 days or make provisions not to fill the sodium hypochlorite tanks during the winter months. The recommended site improvements and location of the proposed facilities are shown in the 30% construction drawings included in Appendix C. Drawings in Appendix C reflect the smaller chemical storage tanks and these will be reevaluated following the perchlorate analysis during final design. Three reservoir chemical feed and mixing systems were evaluated and the Tank Shark is recommended. The engineer’s estimate of probable construction costs for Reservoirs 1 and 2 is approximately \$1.3M and \$1.2M respectively. Note that prior to final design, conducting a CFD model on the selected mixer is recommended to confirm the number of mixers, placement of mixers and the placement of sampling locations within the reservoirs. This will ensure that the reservoirs are getting thoroughly mixed and the sample that is being taken is representative of the entire reservoir.

# 1. Introduction

## 1.1 Project Background

Mesa Water® District (Mesa Water®) supplies potable water to over 110,000 residents in an 18-square mile area, serving Costa Mesa, Parts of Newport Beach and unincorporated areas of Orange County. Mesa Water® currently meets its potable water demand from five active clear wells and the Mesa Water Reliability Facility (MWRF) that treats the deep aquifer amber colored water. Water from the clear wells and the MWRF Facility is pumped directly into the potable water distribution system. Surplus water is delivered to the storage reservoirs, Mesa Water Reservoirs 1 and 2. Reservoir storage augments potable water supplies when water demands exceed the production of the five (5) clear wells and the MWRF.

Mesa Water® uses chloramine as the primary disinfectant at the well sites and the MWRF facility. The surplus water can carry a chloramine residual when it enters the reservoirs. Each reservoir is currently equipped with a chlorine, 12.5% (by weight) sodium hypochlorite chemical feed system to boost the residual by converting free ammonia to chloramine. However, despite the addition of sodium hypochlorite, Mesa Water® has experienced degraded water quality in its existing potable water reservoirs and portions of the potable water distribution system as a result of nitrification. The nitrification is primarily due to a loss of chlorine residual, excess free ammonia and water age within the existing reservoirs and distribution system.

To address nitrification issues being experienced within the existing reservoirs and distribution system, Mesa Water® prepared a Nitrification Control Study (Carollo, October 2016). One of the high priority recommendations in the Nitrification Control Study recommended Mesa Water® implement a complete chloramine booster station including ammonia addition and installation of a control system to adjust chlorine and ammonia dosing based on residuals measured at the reservoir outlet at each reservoir. Mesa Water® retained Hazen and Sawyer and Richard Brady and Associates to complete an evaluation of the existing reservoir mixing system, reservoir chemical feed system and controls at Mesa Water®'s Reservoirs 1 and 2, shown in Figure 1-1 and Figure 1-2, respectively and make recommendations for improvements.



Figure 1-1. Reservoir 1 Site Location Map



Figure 1-2. Reservoir 2 Site Location Map

## 1.2 Purpose

The purpose of this Preliminary Design Report (PDR) is to provide a detailed description of the project, provide a detailed evaluation of the existing reservoir water quality, reservoir mixing system, chemical dosing system, and instrumentation and control systems and provide recommendations for improvements at Mesa Water®'s Reservoirs 1 and 2. The scope of this report includes the following:

- **Chemical Dosing System and Water Quality Monitoring** – Provide a comprehensive evaluation, including recommendations for improvements of the existing water quality issues at each reservoir and the water quality monitoring and chemical dosing systems to provide a 30 day supply of chemical storage.
- **Preliminary Site Design** – Develop a conceptual design for the proposed improvements including relocation of the chemical injection points.
- **Process and Mechanical Design** – Utilizing operational data provided by Mesa Water, confirm the overall design of the process and include major design parameters for the chemical storage and dosing systems.
- **Instrumentation and Controls Design** – Review the existing power, chemical controls and SCADA systems at each reservoir site and provide recommendations for improvements to accompany the proposed improvements to the chemical dosing systems.
- **Estimate of Probable Construction Costs** – Develop an AACE level 4 cost estimate based on the proposed improvements.
- **Construction Schedule** – Prepare a proposed schedule for the construction of all project elements.
- **Technical Specifications/Construction Drawings** – Prepare a complete list of proposed technical specifications and construction drawings for the proposed improvements.

Information from this report has been be utilized to develop process and instrumentation diagrams (P&ID's) and 30% construction drawings that are discussed herein and provided in Appendix B and Appendix C.

## 2. Existing Reservoir Operation and Water Quality

### 2.1 Existing Reservoir Operation

Reservoir 1 has a capacity of 10 MG and it has two operation modes, fill or empty. Surplus water enters and exits the reservoir in a common inlet and outlet pipeline. Water quality samples are collected during filling and emptying of the reservoir as well as when the water is idle in the reservoir via the common inlet and outlet pipeline. Sodium hypochlorite is manually dosed through two existing SolarBee mixers until sampling shows the target residual concentration has been reached. Reservoir 1 has two online analyzers, a prominent chlorine analyzer and a Hach APA 6000 ammonia/monochloramine analyzer.

Reservoir 2 has a capacity of 18 MG and operates in two modes, fill or empty. Surplus water enters and exits the reservoir in a common inlet and outlet pipeline. Water quality samples are collected during filling and emptying of the reservoir as well as when the water is idle in the reservoir. Water quality samples are collected via the common inlet and outlet pipeline. Sodium hypochlorite is manually dosed through one existing SolarBee mixer until sampling shows the target residual concentration has been reached. Reservoir 2 is equipped with two online analyzers, a prominent chlorine analyzer and a Hach APA 6000 ammonia/monochloramine analyzer. The analyzer reads the residual in the common inlet and outlet pipeline. The common inlet and outlet pipeline at Reservoir 2, which is also representative of Reservoir 1, is shown in Figure 2-1.



**Figure 2-1. Reservoir 2 Common Inlet and Outlet Pipe**

To control nitrification, Mesa Water® operators perform breakpoint chlorination procedures in the following order:

- The reservoir is drained to approximately 5 ft or below,
- Chlorine is added either by manually spreading granular or powdered calcium hypochlorite (Reservoir 1) or metering in liquid hypochlorite (Reservoir 2) with a target free chlorine residual of 0.5 mg/L, and
- The water with free chlorine is left to sit for 3, 6 or 24 hours and then the reservoir is gradually filled as surplus water is available.

Mesa Water® operators indicated that they perform the nitrification control process at both reservoirs approximately every 12 weeks and that the frequency increases during the warmer months.

## **2.2 Nitrification Chemistry**

Mesa Water® utilizes chloramine as the primary disinfectant, and chloramines are formed using liquid ammonia hydroxide and 12.5% (by weight) sodium hypochlorite. The benefit of chloramination instead of chlorination is the reduction of trihalomethanes and other disinfection byproduct formation.

However, chloramine can decay to ammonia which can be oxidized by ammonia oxidizing bacteria (AOB) which causes nitrification problems. AOBs are chemolithotrophic nitrifying bacteria that oxidizes ammonia to nitrite and nitrate by using oxygen as an electron acceptor. The first step is the oxidation of ammonia to nitrite via the following mechanism:

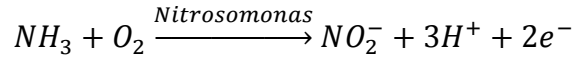

The second step is to convert nitrite to nitrate as shown in the following equation:

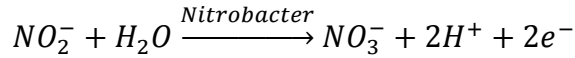

Chloramine is formed when ammonia is added to chlorine (Figure 2-2). For chlorine to ammonia nitrogen mass ratio ( $\text{Cl}_2:\text{NH}_3\text{-N}$ ) up to 5:1, monochloramine is the dominant form for the chloramine. For  $\text{Cl}_2:\text{NH}_3\text{-N}$  mass ratio between 5:1 and 10:1, monochloramine concentration decreases and dichloramine concentration increases. At  $\text{Cl}_2:\text{NH}_3\text{-N}$  mass ratio greater than 10:1, free chlorine can be present and lead to breakpoint chlorination. Free ammonia can lead to nitrification, therefore, the  $\text{Cl}_2:\text{NH}_3\text{-N}$  mass ratio of 5:1 is optimal to minimize free ammonia and to maintain the chlorine residual.

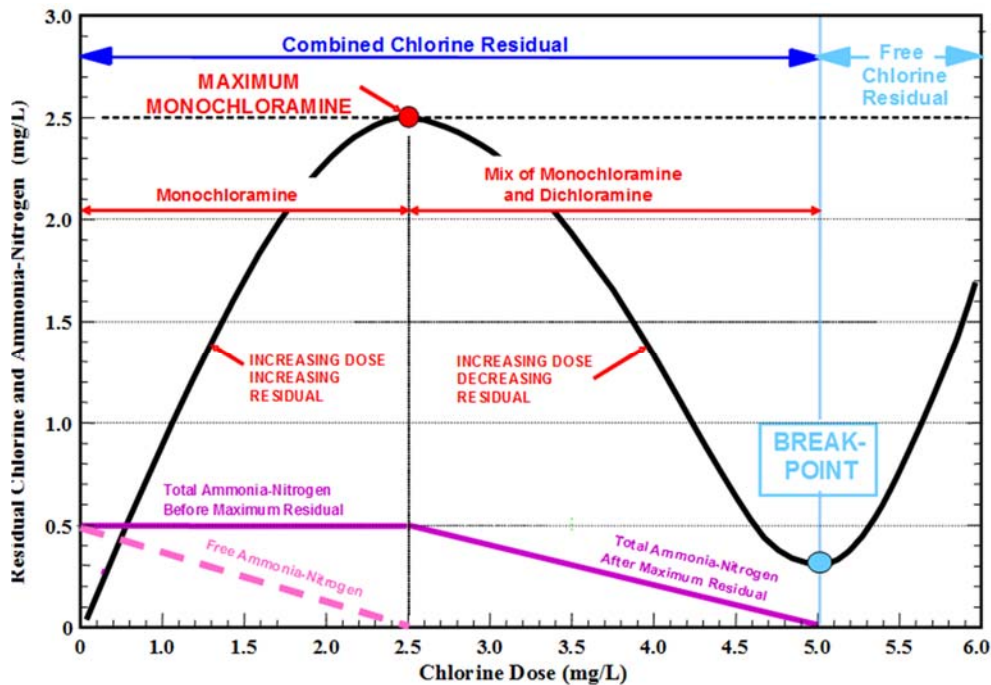

Figure 2-2. Breakpoint Chlorination Chart

Factors that can affect AOB growth are as follows:

- Temperature (optimal growth occurs between 25 to 30 °C (77 to 86°F))
- Chlorine residual (2.0 mg/L total chlorine may inhibit AOB growth)
- Chlorine to ammonia ratio (minimizing free ammonia can minimize electron source for AOB).

## 2.3 Reservoir Water Quality

### 2.3.1 Reservoir Effluent

This section reviews the reservoir water quality, including nitrite, total chlorine, monochloramine, total ammonia, temperature, and pH. Water quality samples for both reservoirs are typically collected on Monday, Wednesday and Friday. At Reservoir 1 samples are collected at the same port as the online analyzer.



Figure 2-3. Reservoir 1 Water Quality Analyzer



Figure 2-4. Reservoir 2 Water Quality Sampling Location



At Reservoir 2, the online analyzer is located on the common inlet and outlet pipeline and the water sampling station is located at the curb on Orange Avenue. A summary of the water quality for Reservoirs 1 and 2 is presented in Table 2-1. This summary is based on SCADA data from November 2014 through November 2015 that was provided by Mesa Water®. Examination of the data provided indicates that the free ammonia data from 2015 may not have always been converted accurately. This is evidenced by the presence of total chlorine while all total ammonia is in free form for some of the data points. Therefore, for purposes of the water quality analyses herein, free ammonia concentrations were calculated (utilizing the original SCADA data provided by Mesa Water®) by subtracting ammonia bound to chlorine from the total ammonia.

**Table 2-1. Reservoir Water Quality from November 2014 to November 2015**

Parameter (Unit)	Reservoir 1		Reservoir 2	
	Average	Range	Average	Range
Nitrite (mg/L as N)	0.0087	0-0.045	0.017	0.001-0.076
pH (s.u.)	8.1	7.0-8.8	8.3	7.2-8.8
Temperature (°F)	75	66-81	77	67-85
Total Ammonia (mg/L as N)	0.34	0.06-0.58	0.39	0.02-0.62
Total Chlorine Residual (mg/L)	1.4	0.22-2.8	1.6	0.44-2.6
Chlorine to Ammonia-N Mass Ratio	4.2	2.6-6.1	4.1	0-8.5

Nitrite concentrations in Reservoirs 1 and 2 are shown in Figure 2-5. Prior to August 2015, the nitrite concentration in Reservoir 1 remained primarily below 0.010 mg/L as N. Between August and October 2015, the nitrite concentrations were primarily between 0.010 and 0.025 mg/L as N. From October to November 2015, the nitrite concentrations are primarily between 0.015 to 0.045 mg/L as N. In general, nitrite concentrations escalated in Reservoir 1 over the course of the year. Prior to July 2015, Reservoir 2 contained less than 0.010 mg/L nitrite as N. After July 2015, nitrite concentrations spiked, and it varied from 0.003 to 0.076 mg/L. Based on one year of water quality data provided by Mesa Water®, frequent higher levels of nitrite (greater than the alarm level of 0.025 mg/L as N) in the reservoirs suggested nitrification occurred frequently within the reservoirs.

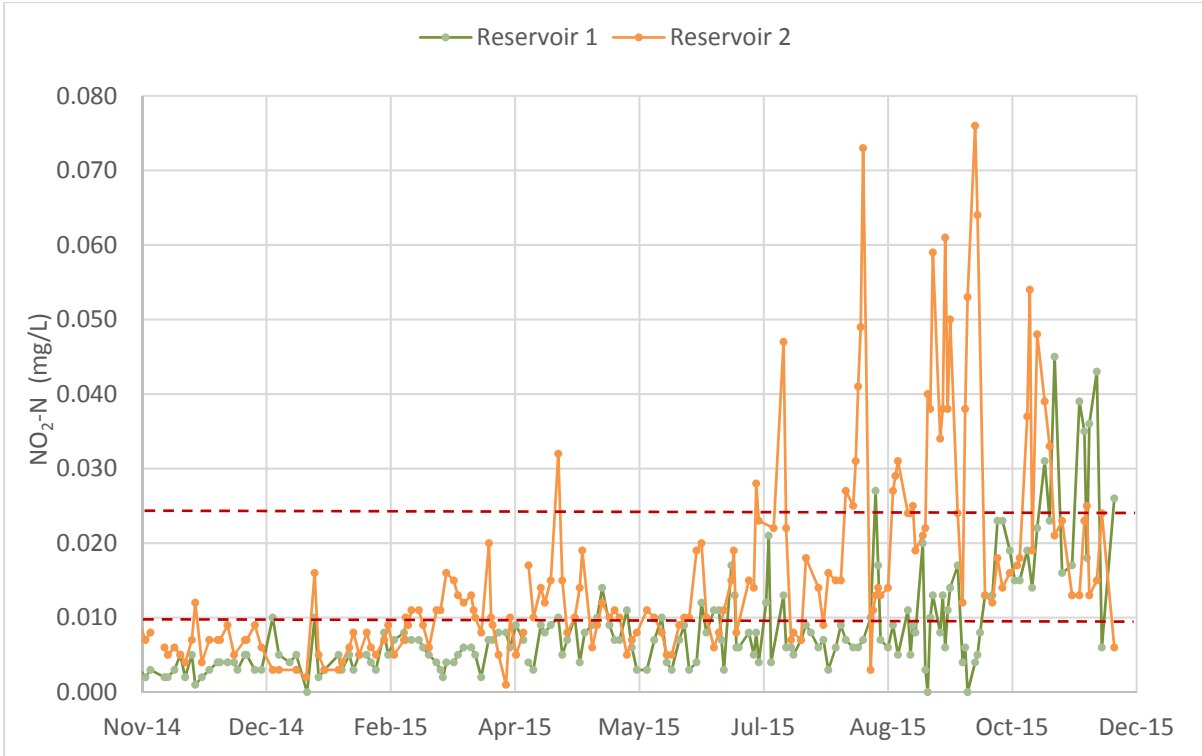

**Figure 2-5. Nitrite Concentration in Reservoirs 1 and 2 from November 2014 to November 2015**

Water temperature in Reservoir 1 is shown in Figure 2-6, and it ranged from 66 to 81 °F from November 2014 to November 2015. Water temperature in Reservoir 2 is shown in Figure 2-7 which ranged from 67 to 85 °F. Prior to July 2015, nitrite concentrations were primarily below 0.010 mg/L as N, and the concentrations escalated after July. This suggests that relatively constant water temperature did not attribute to nitrification problems in either of the reservoirs.

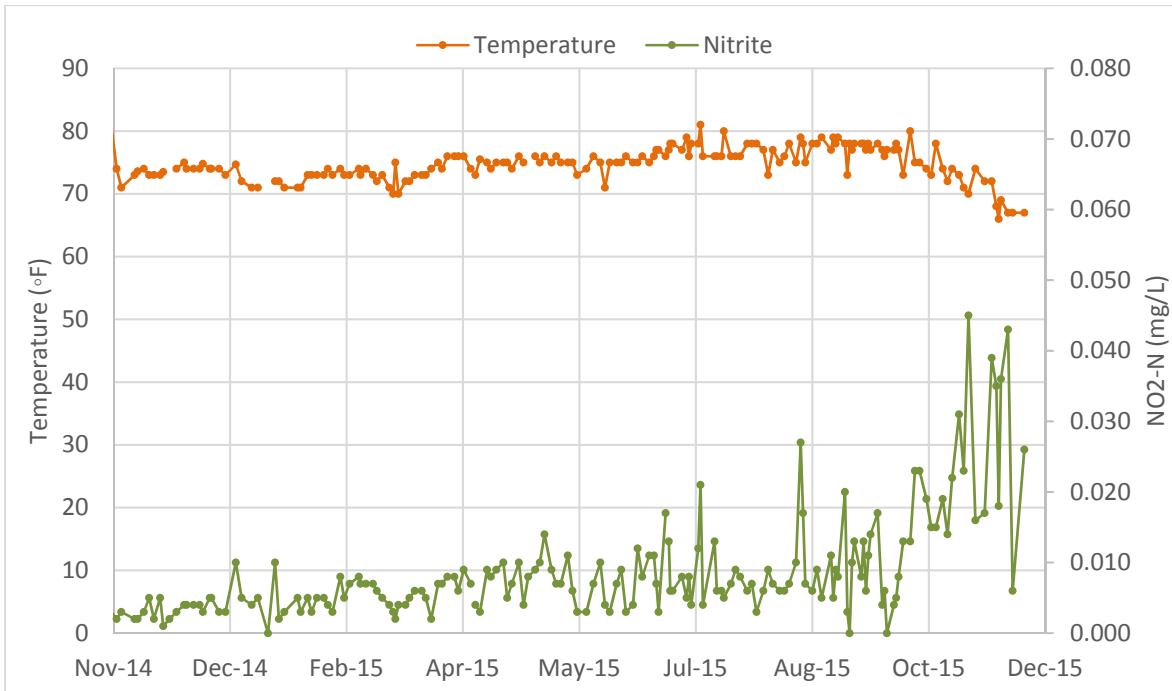

Figure 2-6. Water Temperature in Reservoir 1 November 2014 to November 2015

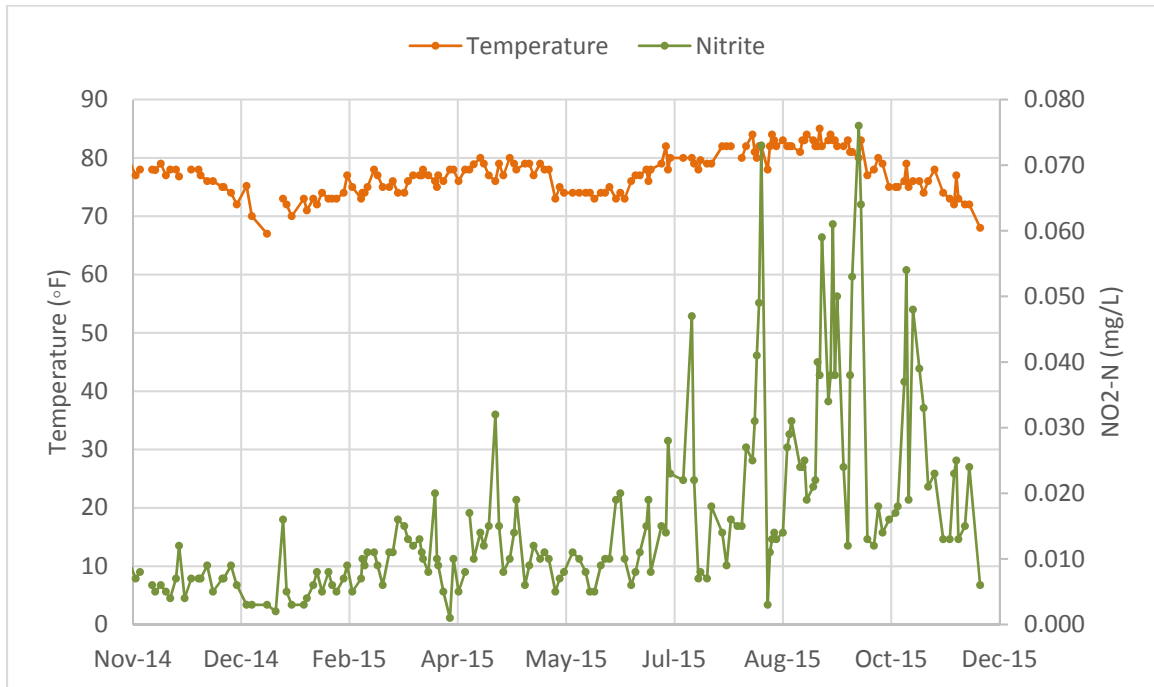
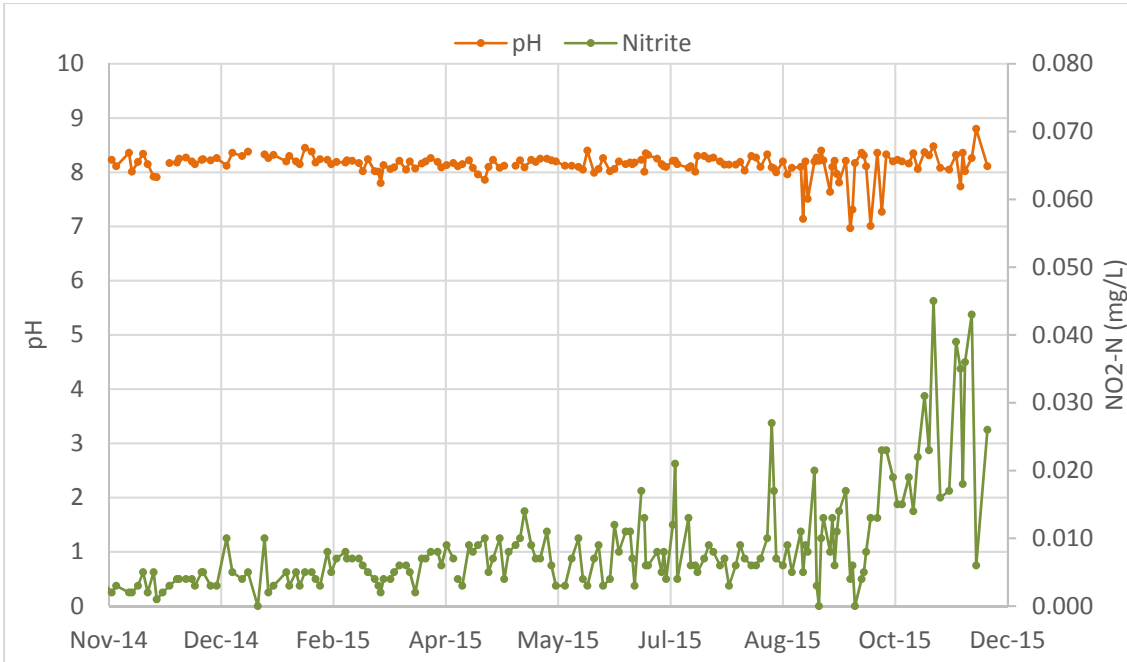

Figure 2-7. Water Temperature in Reservoir 2 November 2014 to November 2015

The pH of the water in Reservoir 1 is shown in Figure 2-8, and it ranged from 7.0-8.8 from November 2014 to November 2015. The pH of the water in Reservoir 2 is shown in Figure 2-9, and it varied

from 7.2-8.8. The pH fluctuations between August and October in both reservoirs may be a result of nitrification as this biological process can lower the pH of the water.



**Figure 2-8. Water pH in Reservoir 1 November 2014 to November 2015**

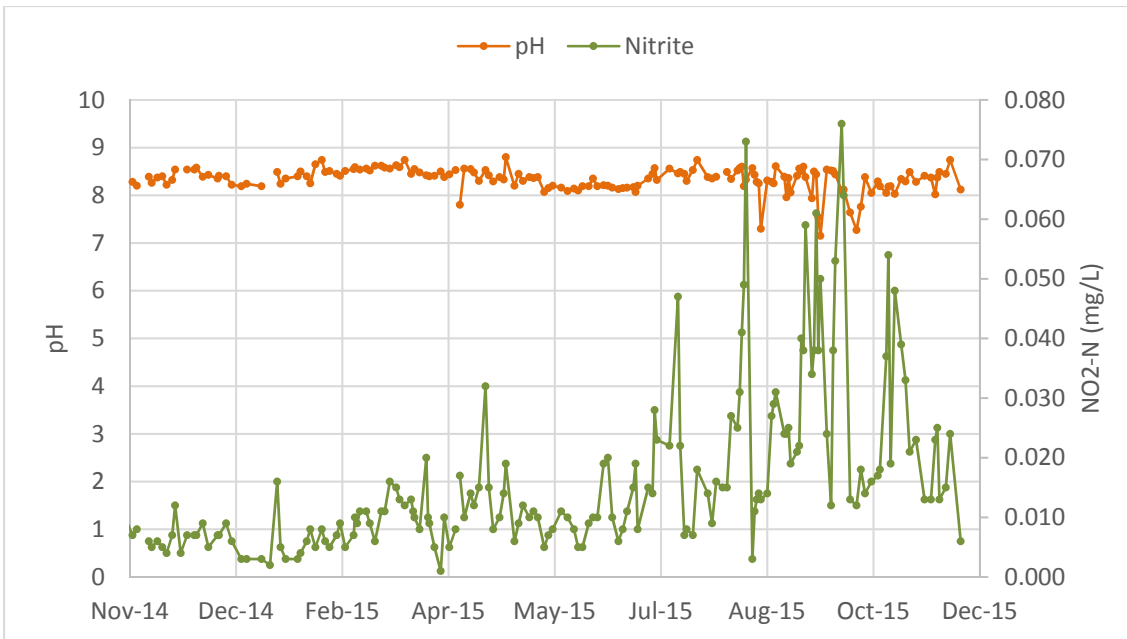

**Figure 2-9. Water pH in Reservoir 2 November 2014 to November 2015**

The total chlorine residual in Reservoir 1 ranged from 0.22 to 2.8 mg/L as shown in Figure 2-10. The total chlorine residual primarily remained above 1.5 mg/L prior to July 2015. The total chlorine

residual fluctuated between 0.22 to 2.8 mg/L after July 2015, and the residual was mostly below 1.5 mg/L. The total chlorine in Reservoir 2 is depicted in Figure 2-11. The total chlorine residual was primarily above 1.5 mg/L prior to July 2015 and was mostly below 1.5 mg/L after July 2015. Nitrite concentrations rose above background levels after July 2015 which suggests that nitrification in the reservoirs is likely due to problems with maintaining adequate chlorine residuals.

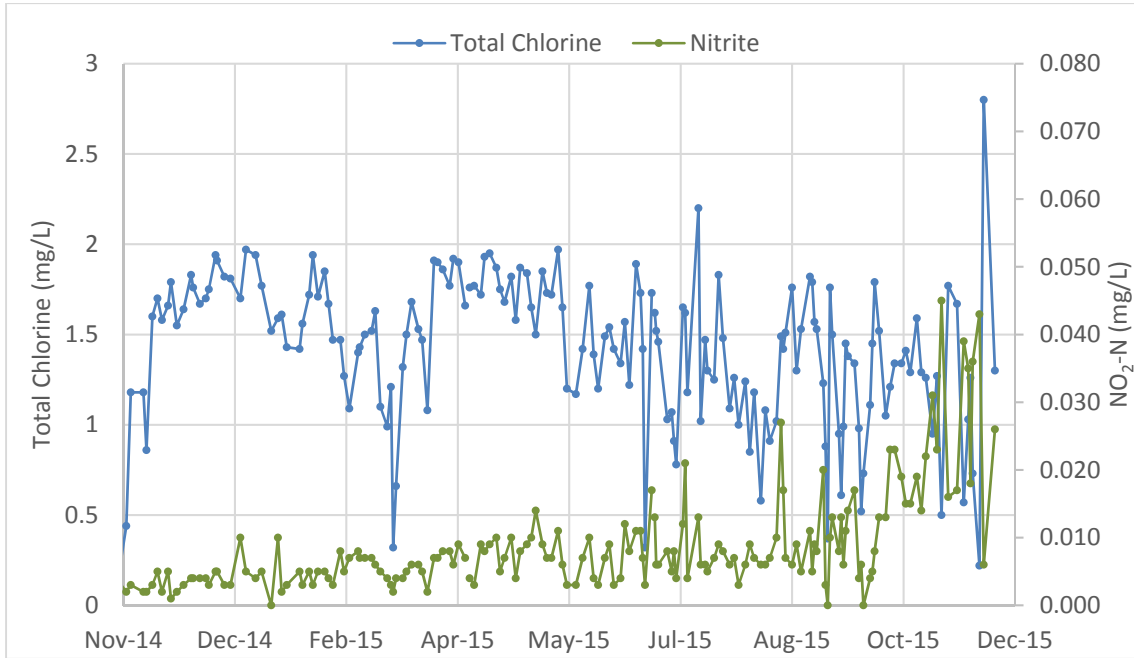

**Figure 2-10. Total Chlorine Residual in Reservoir 1 November 2014 to November 2015**

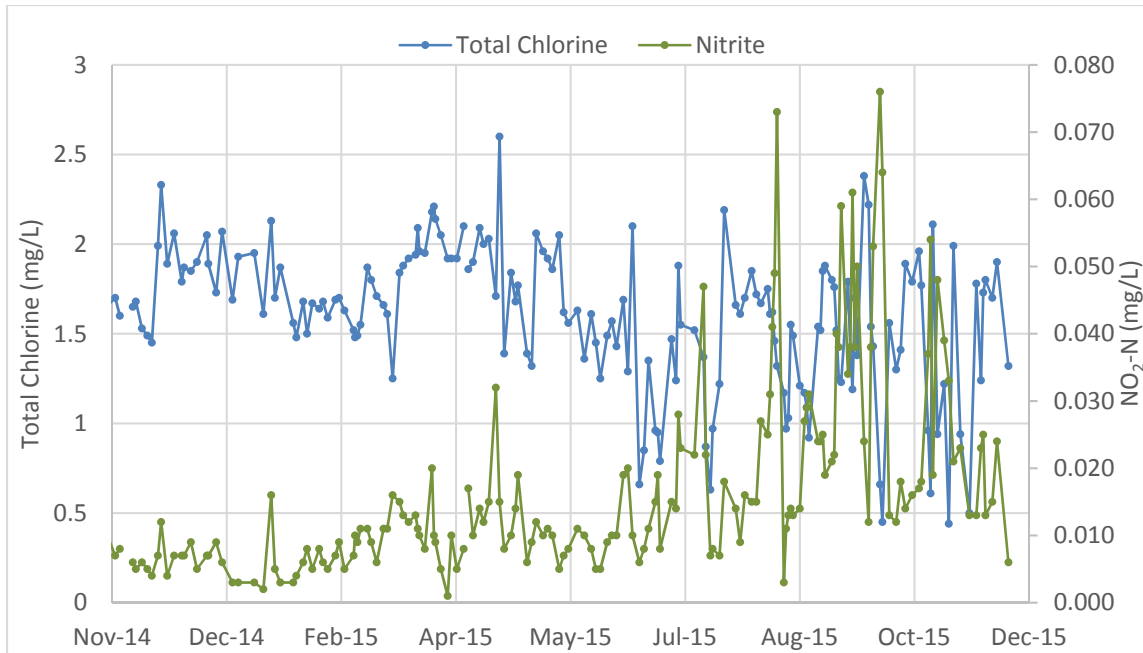

Figure 2-11. Total Chlorine in Reservoir 2 November 2014 to November 2015

### 2.3.2 Reservoirs Response plan

Nitrification events can be identified based on the nitrite concentrations present. These three action levels are provided by the Division of Drinking water and are also depicted in Figure 2-12.

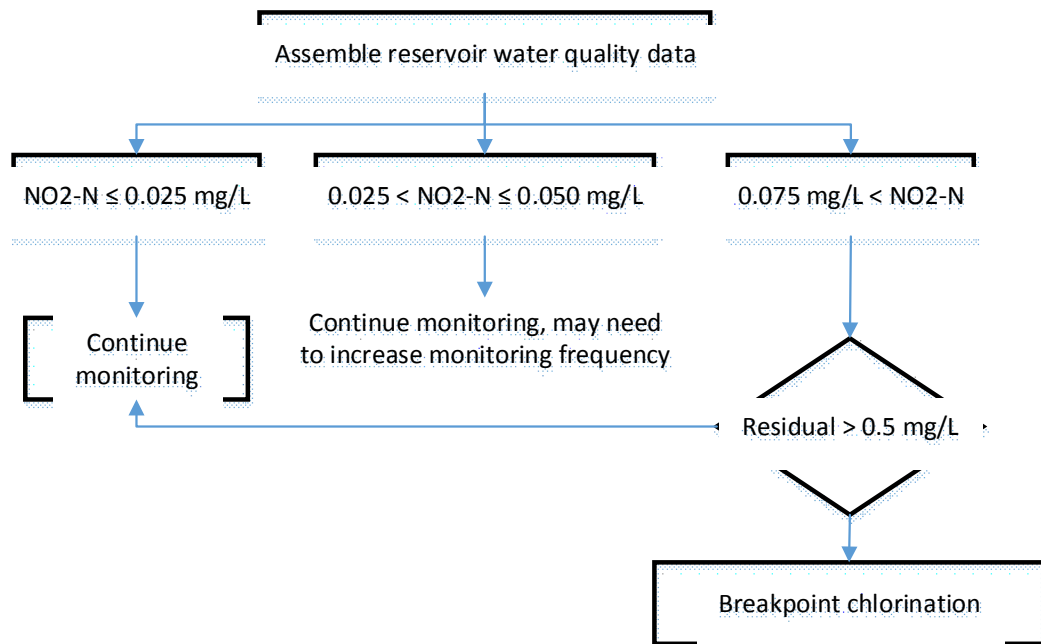

Figure 2-12. Decision Tree for Nitrification Action Levels

## **2.4 Nitrification Mitigation and Reservoir Operational Improvements**

Water quality data from 2015 for Reservoirs 1 and 2 that was provided by Mesa Water® indicates that nitrification is occurring. Factors that contribute to nitrification in the reservoirs include inadequate residual concentrations in the reservoirs, prolonged water age, incomplete breakpoint chlorination, and inadequate mixing. Even though total chlorine averaged 1.4 mg/L in Reservoir 1 and 1.6 mg/L in Reservoir 2, the large fluctuations in the residual concentrations for both reservoirs (0.22 to 2.8 mg/L) and (0.44 to 2.6 mg/L) in Reservoirs 1 and 2 respectively, may allow AOB growth when the residual is low. The Nitrification Control Study (Carollo, October 2016) also documented inter reservoir water transferring, leading to long retention times. Inadequate mixing also leads to dead space, non-uniform water quality, and unequal exposure of the biofilm to the chlorine. Incomplete breakpoint chlorination may not kill AOB and the surviving AOB can regrow. During breakpoint chlorination, only the bottom section of the reservoir with standing water is treated with free chlorine (operators indicated 5 feet), and AOB may still exist in the interior surface above the water line. To improve reservoir water quality, reservoir management improvements are described below.

### **2.4.1 Chemical Feed and Water Quality Monitoring**

The current strategy for water quality monitoring at Reservoirs 1 and 2 is to sample at the common reservoir inlet and outlet and operators respond to low chlorine residual readings by manually dosing 12.5% (by weight) sodium hypochlorite which is delivered through the laminar flow of SolarBees. At Reservoir 1, 7.5 mL/min of sodium hypochlorite is dosed through each of two SolarBees. At Reservoir 2, 15 mL/min of 12.5% (by weight) sodium hypochlorite is manually dosed through one SolarBee. By the time the water quality results are available, the water has already been released into the distribution system and water quality in the reservoir may no longer be representative of the water quality results.

To minimize the large swings in the residuals and maintain a consistent total chlorine residual of 2.5 mg/L in the reservoirs, water quality monitoring from locations within the reservoirs and an automatic chemical feed system capable of adjusting the chemical dosing based on real time water quality readings in the reservoirs is recommended.

### **2.4.2 Reservoir Mixer System Improvements**

A well-mixed reservoir should have minimal dead space, should not be subject to stratification and have uniform water quality. Uniform reservoir mixing can be achieved if the reservoirs are equipped with an adequate number of mixers that have the ability to uniformly disperse chemicals to achieve a stable chlorine residual, minimize dead space and prevent stratification. The SolarBees currently installed in Reservoirs 1 and 2 do not provide adequate mixing to uniformly disperse chemicals or prevent stratification. An additional challenge is the configuration of Reservoir 1. As shown in Figure 3-1 in the subsequent section, Reservoir 1 is a rectangular reservoir with concrete baffle walls that divides the reservoir into two sections. There are two 6 ft by 7ft openings in the baffle wall making turnover and circulation of the reservoir a challenge. The challenge at Reservoir 2 is the size of the reservoir. One SolarBee mixer is not adequate to fully mix the 18 MG reservoir. Therefore, it is recommended that the mixing systems at each reservoir be updated. An evaluation and recommendation

for mixing systems and placement of the mixers are discussed in subsequent Sections and detailed information for the mixers evaluated for purposes of this PDR are included in Appendix A..

### **2.4.3 Ammonia Feed Installation at the Reservoirs**

Based on the 2014-2015 water quality information, the total ammonia concentrations in the reservoirs were linearly proportional to total chlorine, and the average total chlorine to total ammonia ratios were 4.2 for Reservoir 1 and 4.1 for Reservoir 2. The total ammonia concentration in Reservoir 1 ranged from 0.06 to 0.58 mg/L as N and total chlorine varied from 0.22 to 2.8 mg/L. The total ammonia concentration in Reservoir 2 ranged between 0.2 to 0.67 mg/L as N and total chlorine ranged from 0.44 to 2.6 mg/L. The low total ammonia concentration corresponded to the low chlorine residual. It is recommended that the chemical feed systems at both Reservoirs 1 and 2 be sized to deliver 2.5 mg/L total chlorine to compensate for the low residuals and to achieve a target chlorine residual of 2.5 mg/L. This would require an ammonia feed system be integrated into the current chemical feed system at each of the reservoirs.

### **2.4.4 Full Reservoir Cleaning and Breakpoint Chlorination**

The frequency of breakpoint chlorination events necessary at the reservoirs indicates that complete breakpoint chlorination may not be occurring. Particle and organic matter can deposit on the bottom and walls of the reservoir, which can shield the microbe and decrease the disinfectant effectiveness. If the reservoirs are due for cleaning, it is recommended that cleaning be performed during low demand periods when the reservoir may be temporarily taken offline. As the reservoir is filled, it is recommended that free chlorine levels above 0.5 mg/L be maintained.

## **3. Chemical Injection System**

This section summarizes the existing sodium hypochlorite injection and storage systems at Reservoirs 1 and 2 and provides an evaluation of recommended chemical feed and reservoir mixing systems to improve water quality based on maintaining a total chlorine residual of 2.5 mg/L in each reservoir.

### **3.1 Existing Chemical Injection System and Chemical Storage**

Figure 3-1 and Figure 3-2 depict the layouts of Reservoirs 1 and 2 respectively. Reservoir 1 is a rectangular 10 MG reservoir and has baffles that divide it into two compartments. Each compartment receives 12.5% (by weight) sodium hypochlorite at 7.5 mL/min via a skid mounted peristaltic metering pump. The sodium hypochlorite metering rate is manually controlled and does not vary with the flow rates nor the chlorine residual in the reservoir. Sodium hypochlorite is delivered through existing SolarBee mixers, one in each compartment of the reservoir. The existing sodium hypochlorite storage tank is approximately 360 gallons and is filled to approximately 350 gallons to prevent chemical overflow. Sodium hypochlorite is delivered to the site approximately once a month.

Reservoir 2 is a circular tank with a capacity of 18 MG. It is equipped with one SolarBee mixer and one peristaltic sodium hypochlorite feed pump that delivers 12.5% (by weight) sodium hypochlorite at 15 mL/min through the SolarBee mixer. The sodium hypochlorite metering rate is manually controlled



and does not vary with the flow rates into the reservoir nor the chlorine residual. The reservoir characteristics and existing chemical feed systems are summarized in Table 3-1.

**Table 3-1. Summary Reservoir Characteristics and Existing Chemical Feed Systems**

	Parameter	Reservoir 1	Reservoir 2
	Volume (MG)	10	18
	Geometric Shape	Rectangular, divided by baffles	Circular
	Dimension	265 ft (L) x 135 ft (W)	
<b>Chemical Feed</b>	Chemical Storage Tank	360 Gallon fill to 350 Gallon	350 Gallons
	Hypo Feed Pump	Blue & White Model A3 (Norprene A3 Tube) and Model M3 (Norprene M3 Tube)	Blue & White Model A3 (Norprene A3 Tube) and Model M3 (Norprene M3 Tube)
	Chemical Feed Rate	15 mL/min – total (7.5 mL/min each side of reservoir)	15 mL/min
<b>Mixing System</b>	Number of Mixers	2	1
	Mixer	SolarBee	SolarBee
<b>Hydraulic</b>	Minimum in Flow (gpm)	90	20
	Maximum in Flow (gpm)	6,960	11,600

As shown in Table 3-1 above, the flow rates into the reservoirs ranged from 90 to 6,960 gpm for Reservoir 1, and 20 to 11,600 gpm for Reservoir 2. Based on a 12.5% (by weight) sodium hypochlorite feed rate preset at 15 mL/min, the two pumps delivered 0.08 to 6 mg/L chlorine to Reservoir 1, and one pump delivered 0.05 to 29 mg/L to Reservoir 2. This is assuming the chlorine feed was in service when water was entering the reservoirs.

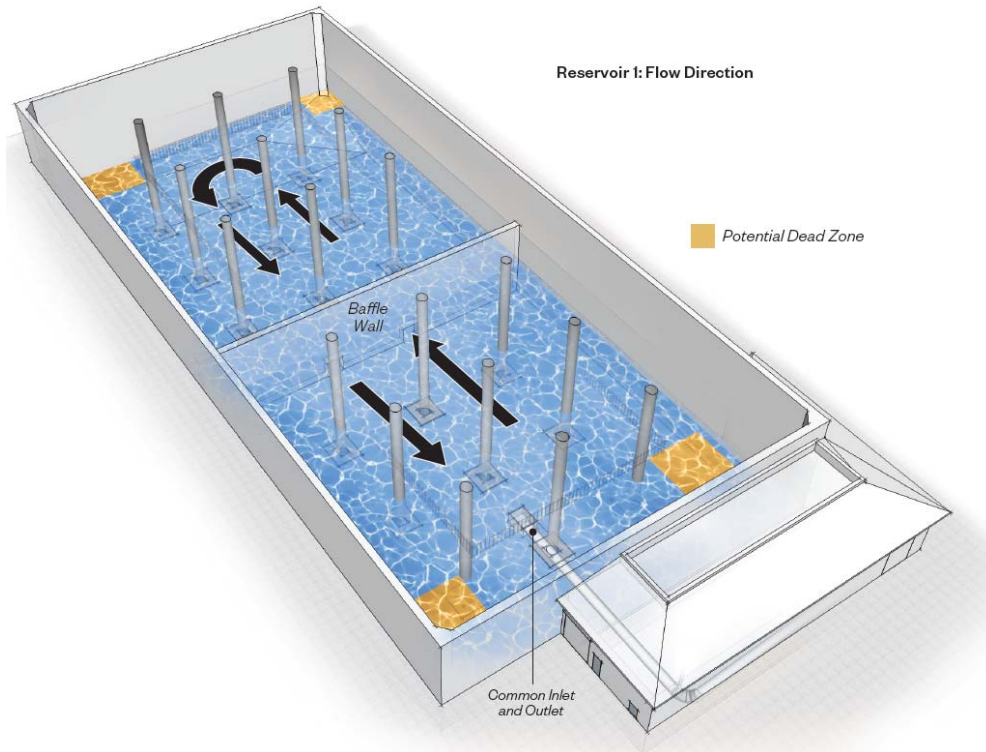

**Figure 3-1. Reservoir 1 Layout and Flow Direction**

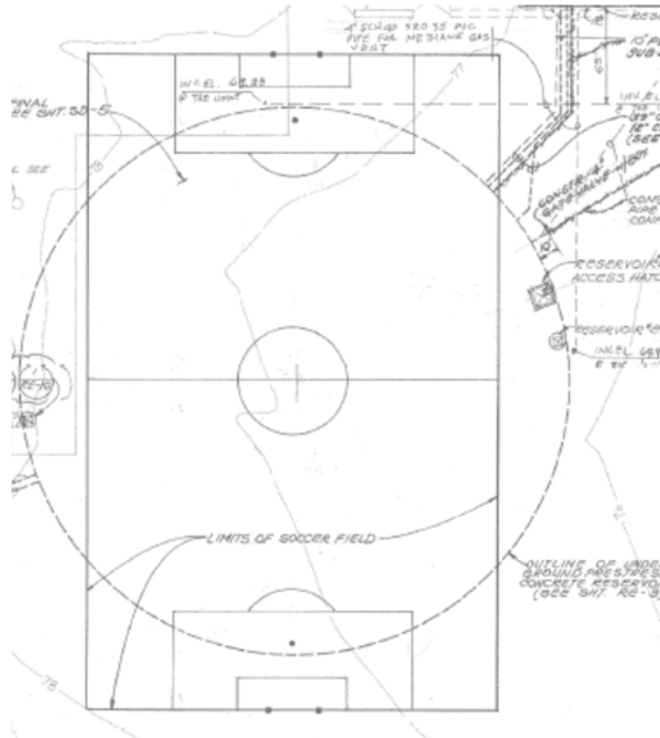

Figure 3-2. Reservoir 2 Layout

## 3.2 Proposed Chemical Storage and Feed System

Presented below is a summary of the proposed sodium hypochlorite and ammonia storage and chemical feed systems.

### 3.2.1 Design Criteria

As previously discussed in Section 2, to control nitrification occurrences in the storage reservoirs, a 5:1 chlorine to ammonia-nitrogen ratio is recommended. The existing sodium hypochlorite feed systems at each reservoir site will be upgraded and new ammonia feed systems will be installed to help maintain a total combined chlorine residual of 2.5 mg/L in the storage reservoirs. Hazen reviewed the historical reservoir effluent water quality SCADA data provided by Mesa Water®, and the reservoirs have typically maintained a chlorine residual of 1.5 mg/L. It is recommended that the chemical feed system be sized to deliver 2.5 mg/L total chlorine to compensate for the low residuals and to achieve a target chlorine residual of 2.5 mg/L. This requires an upgrade to the existing sodium hypochlorite feed system and the addition of an ammonia feed system into the current chemical feed systems at each of the reservoirs.

Based on the 2014-2015 historical flowrates and maintaining a target chlorine residual of 2.5 mg/L, the design parameters for the chemical feed systems is presented in Table 3-2 and are as follows:

**Table 3-2. Chemical Feed Design Criteria**

	Reservoir 1	Reservoir 2
Liquid Ammonia Dose (mg/L as N)	0.5	0.5
Sodium Hypochlorite Dose (mg/L)	2.5	2.5

To size the chemical storage tanks and metering pumps based on existing demand conditions and seasonal dosing rates, historical flowrates and tank turnover were reviewed. Presented in Table 3-3 are the chemical storage recommendations for sodium hypochlorite and liquid ammonia based on the water entering the reservoir having an existing chlorine residual of 1.5 mg/L. These calculations assume that all of the ammonia is bound in the total chlorine.

**Table 3-3. Chemical Storage Requirements with Incoming Residual**

Chemical Storage Component	Reservoir 1		Reservoir 2	
	Avg Inflow	Max Inflow	Avg Inflow	Max Inflow
<b>Sodium Hypochlorite (NaOCl)</b>				
Wt%	12.5%	125%	12.5%	12.5%
SG	1.2	1.2	1.2	1.2
Concentration (lb/gal)	1.2	1.2	1.2	1.2
Target Chlorine Residual (mg/L)	2.5	2.5	2.5	2.5
Average Chlorine Residual (mg/L)	1.5	1.5	1.5	1.5
Additional Chlorine Residual Needed (mg/L)	1	1	1	1
Average monthly Influent Water Volume (MG/mo)	17	24	33	50
Additional Chlorine mass (lb/mo)	145	204	277	417
Additional Chlorine Volume (gal/mo)	121	169	231	347
Existing Chlorine Usage (gal/mo)	151	151	196	196
NaOCl Volume Required (gal/mo)	272	320	426	543
<b>NaOCl Storage Tank Size (gallons)</b>	<b>350</b>	<b>350</b>	<b>500</b>	<b>500</b>
Days of Storage Available	35	30	32	25
<b>Ammonia (NH4OH)</b>				
Wt% (as NH3)	19%	19%	19%	19%
SG	0.93	0.93	0.93	0.93
Concentration (lb/gal as N)	1.25	1.25	1.25	1.25
Ammonia Dose Required (mg/L as N)	0.20	0.20	0.20	0.20
Ammonia mass (lb/mo as N)	29	41	55	83
NH4OH Volume Required (gal/mo)	23	33	44	67
<b>NH4OH Storage Tank Size (gallons)</b>	<b>50</b>	<b>50</b>	<b>100</b>	<b>100</b>
Days of Storage Available	58	41	61	40

As shown in Table 3-3, if the chemical storage system is sized to provide approximately thirty days of storage based on the average and maximum water entering the reservoir having an existing chlorine residual of 1.5 mg/L, a 350 gallon sodium hypochlorite and 50 gallon ammonia tank will be needed at Reservoir 1. This will provide approximately 30 days of storage during the maximum peak flow and 35 days during an average month. At Reservoir 2, a 500 gallon sodium hypochlorite and 100 gallon ammonia tank is needed. This provides approximately 25 and 32 days of storage during the peak and average season at Reservoir 2 respectively.

As requested by Mesa Water, the chemical storage requirements based on the water entering the reservoir having a zero chlorine residual has been calculated and are presented in Table 3-4.

**Table 3-4. Chemical Storage Requirements with Zero Incoming Residual**

Chemical Storage Component	Reservoir 1		Reservoir 2	
	Avg Inflow	Max Inflow	Avg Inflow	Max Inflow
<b>Sodium Hypochlorite (NaOCl)</b>				
Wt%	12.5%	125%	12.5%	12.5%
SG	1.2	1.2	1.2	1.2
Concentration (lb/gal)	1.2	1.2	1.2	1.2
Target Chlorine Residual (mg/L)	2.5	2.5	2.5	2.5
Average Chlorine Residual (mg/L)	0	0	0	0
Additional Chlorine Residual Needed (mg/L)	2.5	2.5	2.5	2.5
Average monthly Influent Water Volume (MG/mo)	17	24	33	50
Existing Chlorine Usage (gal/mo)	363	509	692	1043
NaOCl Volume Required (gal/mo)	302	424	577	869
<b>NaOCl Storage Tank Size (gallons)</b>	<b>500</b>	<b>500</b>	<b>900</b>	<b>900</b>
Days of Storage Available	45	32	42	28
<b>Ammonia (NH4OH)</b>				
Wt% (as NH3)	19%	19%	19%	19%
SG	0.93	0.93	0.93	0.93
Concentration (lb/gal as N)	1.25	1.25	1.25	1.25
Ammonia Dose Required (mg/L as N)	0.50	0.50	0.50	0.50
Ammonia mass (lb/mo as N)	73	102	138	209
NH4OH Volume Required (gal/mo)	58	81	111	167
<b>NH4OH Storage Tank Size (gallons)</b>	<b>100</b>	<b>100</b>	<b>200</b>	<b>200</b>
Days of Storage Available	47	33	49	32

If water entering the reservoir does not have a chlorine residual, a 500 gallon sodium hypochlorite storage tank and 100 gallon ammonia tank is necessary at Reservoir 1. A 900 gallon sodium hypochlorite storage tank and 200 gallon ammonia tank would be required at Reservoir 2.

As discussed in the following Section 3.2.1.1. and based on an American Water Works Association Journal Article (June 2011, Volume 103, No. 6) entitled: Perchlorate, Bromate, And Chlorate in Hypochlorite Solutions: Guidelines for Utilities, if sodium hypochlorite is stored for extended periods of time, there is a risk that perchlorate will form. Perchlorate has been identified as a constituent of concern in hypochlorite solutions which can affect the human thyroid system. A copy of the referenced article has been included in Appendix E for Mesa Water’s reference. To be consistent with Mesa Water’s Well Automation Project and to minimize the frequency of chemical deliveries during peak demand, the larger storage reservoirs have been included in this analysis. Should Mesa Water® opt for the larger storage tanks and implements the recommendations from Technical Memorandum 3 (TM-3) in which storage levels be lowered during the winter season, Hazen recommends that the chemical storage tanks not be fully filled during the low use periods so that perchlorate formation is minimized or consider a less concentrated sodium hypochlorite solution. It is suggested that Mesa Water consider testing the existing sodium hypochlorite tank for perchlorate formation at the existing Well No. 7 site over a two month period during the winter months when water demand is low and turnover of the sodium hypochlorite storage reservoir is low. The purpose of conducting this test is to determine if perchlorates have formed and to what extent. The seasonal levels for filling the sodium hypochlorite

storage tank could then be set such that there is not too much or too little chemicals being used and stored.

### 3.2.1.1 Sodium Hypochlorite Storage Concerns

Sodium hypochlorite can decay because of exposure to sunlight and elevated temperatures. At 20 °C, 12.5% (by weight) fresh hypo can decay to 11.3%. Decay is accelerated at higher temperature, where the concentration can decrease to 10.2% at 25 °C and to 8.6% at 30 °C during the course of 30 days. The hypo degradation was estimated based on AWWA Hypochlorite Assessment Model, and the decay curves are shown in Figure 3-3 for 20, 25 and 30 °C storage temperature. In order to have the optimal Cl:NH<sub>4</sub>-N ratio of 5:1, the hypochlorite concentration shall be verified and updated in the HMI if decay is excessive (>10%) during the entire storage time.

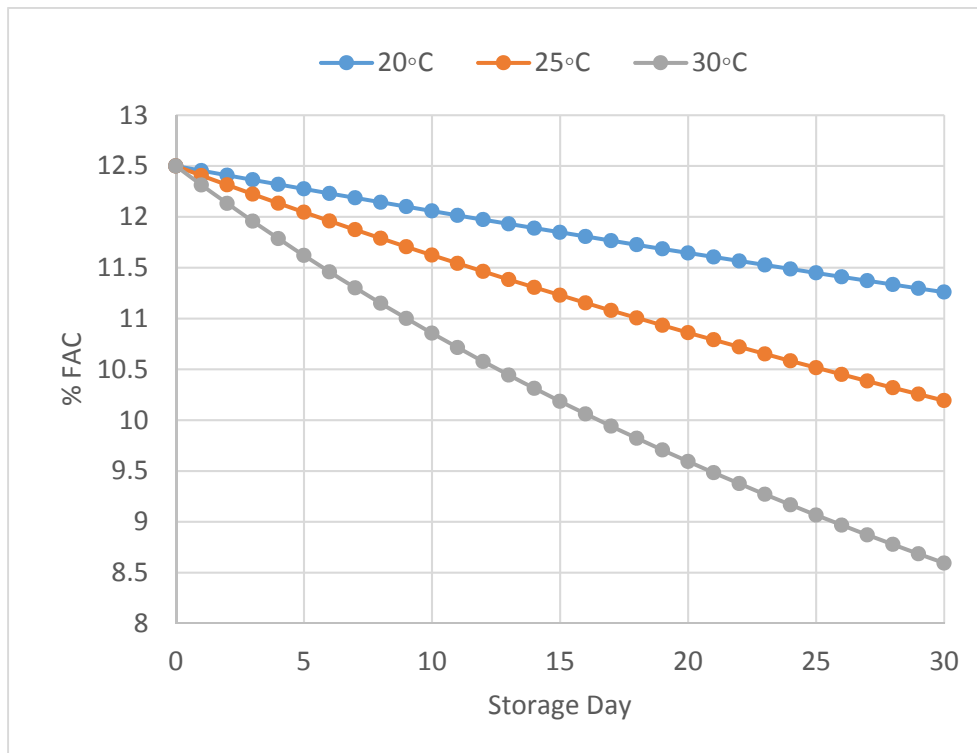

Figure 3-3. Sodium Hypochlorite Decay Curves (AWWA Hypochlorite Assessment Model)

In addition, hypochlorite decay will result in chlorate formation, and minimizing chlorine decay can minimize chlorate formation. California Division of Drinking Water currently has a chlorate notification limit set at 0.8 mg/L, which, based on current discussions, is likely to be regulated in the near future. Chlorate concentrations in finished water are summarized in Figure 3-4 and Figure 3-5 for chlorine doses of 2.5 mg/L and 1 mg/L with hypo stored at different temperatures. Chlorate concentration increases with longer storage times and higher storage temperatures. Therefore, a 30-day supply of sodium hypochlorite stored at ambient temperature at or below 25 °C is recommended. This approach will offer more flexibility in the event that regulation of chlorate is established.

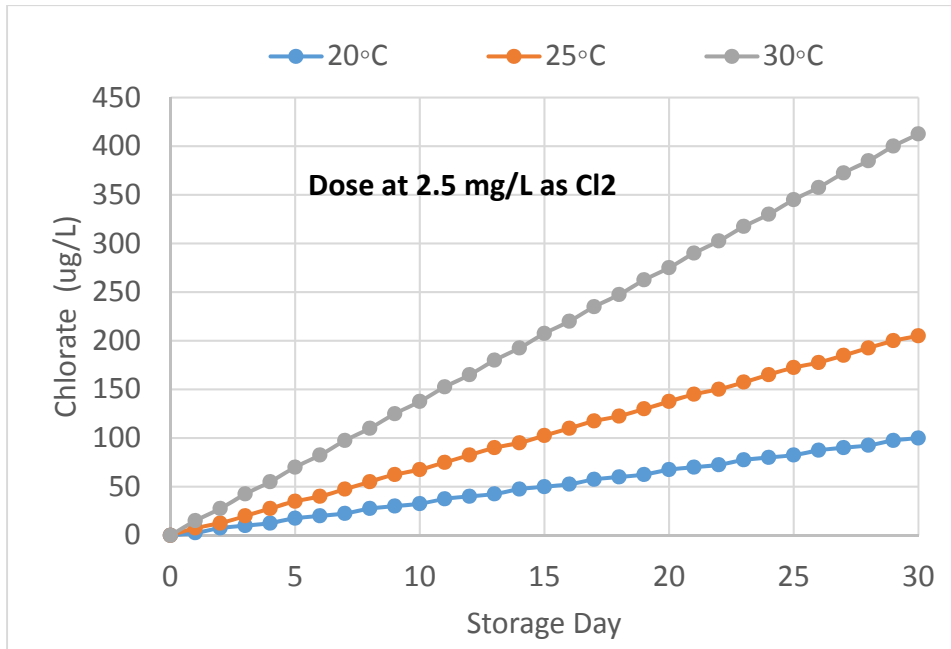

Figure 3-4. Chlorate Concentration as a Function of Chemical Storage, Dosing at 2.5 mg/L Cl<sub>2</sub>

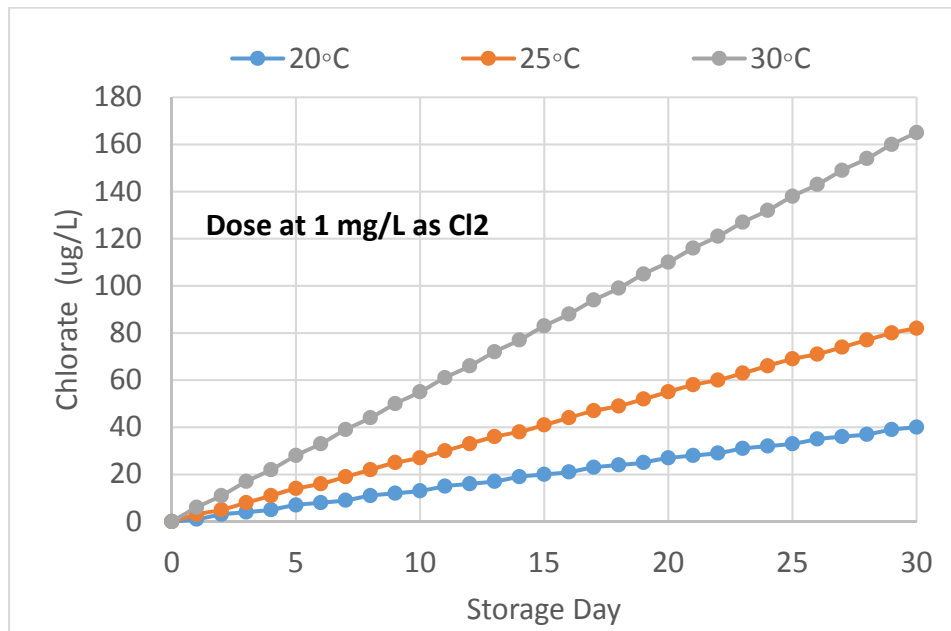

Figure 3-5. Chlorate Concentration as a Function of Chemical Storage, Dosing at 1 mg/L Cl<sub>2</sub>

### 3.2.1.2 Chemical Storage Design Summary

To be consistent with Mesa Water’s Well Automation Project, the sodium hypochlorite storage tanks and ammonia storage tanks are to be fiberglass single-walled, flat bottomed, domed top tanks

manufactured and certified for chemical storage per ASTM D 3299 and ASTM D 4097. The sodium hypochlorite tanks will be equipped with a drain line, fill line, anti-siphon vent, tank vent, level sensor, and overflow line. All fittings and accessories will be located at the top of the storage tank to prevent sidewall tank leaks. The aqueous ammonia storage tanks shall be equipped with proper connections for fill, vapor return, pump suction, temperature probe, level sensor, scrubber vent and drain. The summary details for both the ammonia feed system and sodium hypochlorite feed system for each reservoir site are presented below.

### 3.2.1.3 Reservoir 1

For consistency with Mesa Water’s Well Automation Project, sodium hypochlorite shall be stored in a 500 gallon storage tank and ammonia be stored in a 100 gallon storage tank. The tank details are summarized in Table 3-5. As previously discussed, should testing of the sodium hypochlorite tank at Mesa Water’s Well No 7 indicate degradation and perchlorate formation, Hazen recommends that Mesa Water consider the smaller sodium hypochlorite tank or seasonally adjust the level in which the tank is filled to minimize perchlorate formation.

**Table 3-5. Reservoir 1 Storage Design Summary**

Description	Sodium Hypochlorite	Aqueous Ammonia
Tank Size (inches) <sup>1</sup>	Diameter – 48, Height 76	Diameter – 30, Height 40
Tank Capacity (Gallons)	500	100
Approximate Storage Pad Size (inches)	72 x 72	66 x 49

<sup>1</sup> Tank Size will be modified during final design to accommodate site constraints and perchlorate formation analysis as necessary

### 3.2.1.4 Reservoir 2

Hazen recommends that sodium hypochlorite be stored in a 900 gallon storage tank and ammonia be stored in a 200 gallon storage tank. The tank details are summarized in **Table 3-6** below. As previously discussed, should testing of the sodium hypochlorite tank at Mesa Water’s Well No 7 indicate degradation and perchlorate formation, Hazen recommends that Mesa Water consider the smaller sodium hypochlorite tank or seasonally adjust the level in which the tank is filled to minimize degradation during the winter months.

**Table 3-6. Reservoir 2 Storage Design Summary**

Description	Sodium Hypochlorite	Aqueous Ammonia
Tank Size (inches) <sup>1</sup>	Diameter – 72, Height 48	Diameter – 46, Height 50
Tank Capacity (Gallons)	900	200
Approximate Storage Pad Size (inches)	96 x 96	66 x 66

<sup>1</sup> Tank Size will be modified during final design to accommodate site constraints and perchlorate formation analysis as necessary

### 3.2.2 Feed Pumps

Part of Hazen’s scope of work was to evaluate various chemical feed pumps. Three types of pumps, diaphragm, peristaltic and progressive cavity were evaluated and a description of each are described below. Each type of pump and its applications are summarized in Table 3-7.

Diaphragm Pumps - Can meter most chemicals except for polymer or slurries. Provides lower suction lift, and chemical storage tanks may need to be installed at a higher elevation than the pump to accommodate the low suction lift. Diaphragm pumps have a high turn down ratio that allows metering for a wide range of chemical flow rates. However, the flow rates may not be accurate at low turndown rates.

Peristaltic Pumps – The peristaltic pump is a positive displacement pump that can meter slurries, polymers, sodium hypochlorite, and high viscosity liquids. They can provide high suction lift. The discharge pressure varies with the size of the tubing that is used.

Progressive Cavity Pump - Is suitable for metering polymers and chemicals with high viscosity while providing high suction lift. The turndown ratio is low and the discharge pressure is high.

For chemical metering as discussed herein, both diaphragm and peristaltic pumps can be used to meter ammonia and sodium hypochlorite.

**Table 3-7. Chemical Feed Pump Type Comparison**

Parameter	Diaphragm	Peristaltic	Progressive Cavity
Applications	Most Chemicals, not recommended for polymer or slurries	Chemical slurries, polymers, sodium hypochlorite, high viscosity applications	Polymers, I viscosity chemicals
Typical Manufacturers	Pulsafeeder, Prominent, Wallace and Tiernan, LMI	Watson Marlow, Blue-White	Moyno; Seepex
Suction lift	Low (< 5')	High	High (20'+)
Turndown Ratio	High published ratios	Varies depending on selected pump	Low (Typically 20:1)
Discharge Pressures	Can be very high (20 psi+)	Varies with hose specified	High

To be consistent for the ease of maintenance and stocking parts, it is recommended that Mesa Water® utilize the same metering pumps that are utilized for Mesa Water®’s Well Automation Project. The pumps shall be skid mounted diaphragm metering pumps as manufactured by Pulsafeeder, Inc., Pulsar Series, Milton Roy, MILROYAL Series or equal.

### 3.2.3 Chemical Feed Recommendations

#### 3.2.3.1 Integrated Sodium Hypochlorite Feed System and Tank

The sodium hypochlorite feed system and tankage will consist of fully integrated chemical metering pump skids and chemical storage tanks. Utilizing the same equipment that is utilized for Mesa Water’s



Well Automation Project. The sodium hypochlorite chemical feed equipment at Reservoirs 1 and 2 shall be as follows:

Reservoir 1:

Due to the configuration of Reservoir 1, it is recommended that each 5 MG compartment of the reservoir have a dedicated chemical feed system. Each pump skid shall be configured with one duty pump and one stand by pump to accommodate each injection point.

- One (1) 500 gallon fiberglass tank
- One (1) Coriolis Flowmeter
- Two (2) Dosing Control Panels
- One (1) Gems Suresite Level Indicator
- Four (4) Diaphragm Metering Pumps (2 duty + 2 standby) to deliver up 8 gph each
- Two (2) Dual Chemical Feed Pump Skids with chemical appropriate construction materials
- One (1) Leak Detection System
- Power, Control and Signal Panel
- One (1) Calibration Column
- Two (2) Output Pressure Gauge

Reservoir 2:

- One (1) 900 gallon fiberglass tank
- One (1) Coriolis Flowmeter
- One (1) Dosing Control Panel
- One (1) Gems Suresite Level Indicator
- Two (2) Diaphragm Metering Pumps (1 duty + 1 standby) to deliver up to 15 gph
- One (1) Dual Chemical Feed Pump Skid with chemical appropriate construction materials
- One (1) Leak Detection System
- Power, Control and Signal Panel
- One (1) Calibration Column
- One (1) Output Pressure Gauge



**Figure 3-6. Sample Sodium Hypochlorite Skid**

### **3.2.3.2 Integrated Ammonia Feed System and Tank**

The aqueous ammonia feed system and tankage will consist of fully integrated chemical metering pump skids and chemical storage tanks. Utilizing the same equipment that is utilized for Mesa Water's Well Automation Project, the aqueous ammonia chemical feed equipment at Reservoirs 1 and 2 shall be as follows:

### Reservoir 1:

- One 100 gallon high-density crosslinked polyethylene (XLPE) or Type 2 high-density linear polyethylene (HDLPE) tank.
- One (1) Ammonia tank Vacuum relief vent
- One (1) Vapor Scrubber for Emergency use
- Four (4) Aqueous Ammonia single diaphragm metering pumps with variable speed drive (2 Duty + 2 Standby) to deliver 3 gph
- Vendor Control Panel
- One (1) Coriolis flowmeter
- One (1) Basket Strainer
- Ammonia Tank instrumentation include one (1) level, one (1) high pressure switch, and one (1) fill valve position switch
- Truck Fill Panel
- One (1) tank containment area and one (1) sump area level switch



**Figure 3-7. Sample High-Density Crosslinked Polyethylene (XLPE) Tank**

### Reservoir 2:

- One 200 gallon high-density crosslinked polyethylene (XLPE) or Type 2 high-density linear polyethylene (HDLPE) tank
- One (1) Ammonia tank Vacuum relief vent
- One (1) Vapor Scrubber for Emergency use
- Two (2) Aqueous Ammonia single diaphragm metering pumps with variable speed drive (1 Duty + 1 Standby) to deliver 3 gph
- Vendor Control Panel
- One (1) Coriolis flowmeter
- One (1) Basket Strainer
- Ammonia Tank instrumentation include one (1) level, one (1) high pressure switch, and one (1) fill valve position switch
- Truck Fill Panel
- One (1) tank containment area and one (1) sump area level switch

## **3.3 Reservoir Management Systems**

Reservoirs 1 and 2 are currently equipped with SolarBee mixers, two mixers at Reservoir 1 and one at Reservoir 2. Based on experience at other similar installations, it is doubtful that the SolarBee has the capacity to provide adequate mixing which has likely contributed to water quality degradation and nitrification issues within the reservoirs. Improving the reservoir management system (RMS) can improve the reservoir circulation, maintain stable chlorine residuals and uniform water quality and, therefore, lower the maintenance requirements by mitigating nitrification. The management systems evaluated for improving Mesa Water®'s reservoir mixing included Vortex™ mixers by Superior Water Technologies, PAX Water Mixers by PAX Water Technologies, and Tank Shark™'s Mixing System by UGSI Solutions Company. It should be noted that PAX is now part of UGSI and utilizing combinations of equipment from each system are an option.

Each reservoir mixing system is described in detail below and Table 3-8 summarizes the characteristics of each RMS. Detailed product drawings and budgetary cost estimates for each mixing system are provided in Appendix A. The process and instrumentation diagrams for each mixing system are provided below and included with the 30 % construction drawings in Appendix B.

### 3.3.1 Vortex RMS by Superior Water

Superior Water Technologies Vortex™ RMS is constructed out of SS316 or anodized aluminum and cased in a tamper-proof enclosure. The mixer lowers into the reservoir from the top through a 6 to 8-inch diameter hole with the mixer being installed a few feet above the reservoir bottom. Hatch is not required for the installation. The mixer housing also contains two chemical injection ports for introducing chlorine and ammonia that eliminates chemical feed line installation. The mixing pump and electrical conduit are encased in a stainless steel box on top of the reservoir. The mixer has the suction nozzle on the bottom where the pump draws the water from the reservoir. The pump pressurizes the water and injects it back to the reservoir through a vortex nozzle assembly. The expelled water from the nozzles forms a water jet stream that creates both horizontal and vertical mixing. The jet stream also mixes chlorine and ammonia since the chemical feed outlet is next to the nozzle. A water sampling line is installed on the suction side of the pump, which allows for collection of the sample near the mixer. Superior RMS works more efficiently when the reservoir has a higher water level. An example of a Vortex mixer installed is shown in Figure 3-8 and more information specific to the chemical feed and Vortex Reservoir Mixing System is included in Appendix A. The P&ID is included in Appendix B.

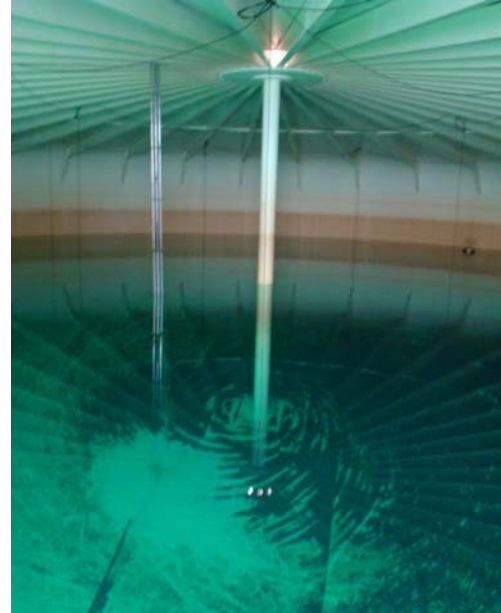

**Figure 3-8. Vortex Mixer Reservoir Installation**

During maintenance, operators can lift the Vortex RMS from the top of the reservoir, and a diver or boat is necessary. Estimated time for extraction is less than 2 hours. This allows standard maintenance to be performed without the need for confined space certification and avoidance of other safety hazards created by tank entry. This configuration will not work at the Reservoir 2 site due to the need to install the equipment above the buried reservoir and the site being utilized as a recreational area. For ease of maintenance, Mesa Water is standardizing its equipment and, therefore, the Vortex RMS was not further developed as an alternative.

### 3.3.2 PAX

PAX Water Technologies RMS sits on the bottom of the reservoir, and the RMS lowers into the reservoir through an existing hatch. Divers must perform installations that are not directly under the hatch. The PAX RMS has a tripod support and a tornado shaped rotator that spins and creates tornado pattern mixing. The electrical conduit is in contact with water, which may need additional installation precaution. The mixer is not equipped with chemical feed ports, and chemical feed lines must be

installed above the mixer to inject sodium hypochlorite and ammonia, and the mixer disperses the added chemicals. This chemical feed configuration may result in premature chemical feed line clogging. Off hatch location of the mixers require a diver for extraction during maintenance. An example of the PAX mixer is shown in Figure 3-9 and more detailed information on the reservoir mixing system and the P&ID are included in Appendix A and Appendix B, respectively.



**Figure 3-9. PAX Mixer Installation**

### **3.3.3 Tank Shark by UGSI Solutions**

Installation of UGSI Solutions' Tank Shark RMS is similar to the PAX RMS where it lowers into the reservoir through a hatch. Off hatch installations must be performed by a diver. The mixer consists of water jet ports, two chemical injection ports, and a water sampling port. An external reservoir circulation pump primes the water and the pressurized water returns to reservoir through the mixer jet ports to form jet mixing. There are two injection ports for ammonia and sodium hypochlorite, and the jet streams disperse the chemicals. The sampling port can connect to an online analyzer. No electrical conduits are in contact with the water. Extraction of the Tank Shark RMS for maintenance is similar to PAX RMS. The detailed cut sheets and P&ID for the Tank Shark reservoir mixing system is included in Appendix A and Appendix B, respectively.



Figure 3-10. Tank Shark Installation

Table 3-8. Summary Reservoir Mixing Systems Evaluated

Parameters	Vortex	PAX	Tank Shark
Installation	Mixer lowers into the reservoir via a 6-8 inch diameter hole in the top of the reservoir	Mixer lowers into the reservoir through a hatch, and off center installation requires diver	Mixer lowers into the reservoir through a hatch, and off center installation requires diver
Material of Construction	316 SS or Anodized Aluminum	316 SS	316 SS
Mixing	Jet Mixing	Mechanical Mixing	Jet Mixing
Maintenance	Mixers extraction from the top of the reservoir, no diver required	Mixer installed under the hatch is extracted by pulling, off center mixer requires extraction by diver	Mixer installed under the hatch is extracted by pulling, off center mixer requires extraction by diver
Chemical Feed	Two chemical feed ports in the mixer housing. Chemicals are introduced through the ports and dispersed by the jet mixing	Chemical feed lines are suspended on top of the mixer, and mechanical mixing will disperse the chemicals; chemical feed attachments are available	Two chemical feed ports in in the mixer stand. Chemicals are introduced through the ports and dispersed by the jet mixing
Sample port	One external sample location available in the external housing that encapsulates the pump, it draws water near the mixer	No sample port on the mixer.	Two external sample locations, one location draws water near the mixer, the other location draws water next to the circulation pump
Electrical Conduits	Electrical conduits is part of metal case that sit on top of the reservoir	Electrical conduit is in contact with water	Electrical conduits are external to the reservoir
Warranty	10 years	3 years	3 years

Hazen’s observed advantages and disadvantages of each mixing system are summarized in Table 3-9 below.

**Table 3-9. Reservoir Mixing Systems Comparison**

Mixing System	Advantages	Disadvantages
Vortex	<ul style="list-style-type: none"> <li>• Easy installation</li> <li>• No additional chemical feed lines</li> <li>• Maintenance does not require a diver</li> <li>• No electrical parts in contact with water</li> <li>• 10 year warranty</li> <li>• No chemical wiring inside of the tank</li> <li>• No confined space entry needed</li> </ul>	<ul style="list-style-type: none"> <li>• Requires a minimum water level for mixer to work</li> <li>• Above ground installation will not work at the Reservoir 2 site</li> <li>• Location of pump on top of tank makes priming of pump an operational challenge</li> </ul>
PAX	<ul style="list-style-type: none"> <li>• Easy installation in the presence of hatch</li> </ul>	<ul style="list-style-type: none"> <li>• Electrical parts in contact with water</li> <li>• Diver needed to install mixers in reservoirs without hatch or if mixer is not placed under hatch</li> <li>• Mixer can weigh up to 90 pounds</li> <li>• Requires additional chemical feed line above the mixer, which is prone to clogging</li> <li>• 3 year warranty</li> <li>• Confined space entry for off hatch mixer installation and extraction</li> </ul>
Tank Shark	<ul style="list-style-type: none"> <li>• Easy installation in the presence of hatch</li> <li>• No electrical parts in contact with water</li> <li>• High velocity in nozzles prevents clogging</li> </ul>	<ul style="list-style-type: none"> <li>• Requires a minimum water level of approx. 60-inches for mixer to work and to prevent air entrapment in the external circulation pump (confirm during final design)</li> <li>• Weight 50 lbs per mixer</li> <li>• Mixer extraction cable is thin and hard to pull, need two people to service it</li> <li>• 3 year warranty</li> <li>• Confined space entry for off hatch mixer installation and extraction</li> </ul>

The above grade configuration of the Vortex RMS will not work at the Reservoir 2 site since the reservoir site is utilized as a recreational playground. Furthermore, Mesa Water is wanting standardization in equipment to simplify maintenance and therefore, the Vortex RMS will not be recommended for either reservoir. It should be noted that each of the reservoir mixing vendors have recommended the placement and number of mixers and chemical dosing locations in different configurations based on their own experiences and their own CFD models for similar sized reservoirs. During final design, a CFD model should be performed to confirm the optimum number of mixers, locations of mixers, chemical dosing locations, and water quality sampling locations. This is especially important for the Reservoir 1 configuration to ensure that water is circulated between the two chambers of the reservoir and to prevent dead zones in the corners of the rectangular reservoir. The recommended locations for the mixer placement in Reservoir 1 for both the PAX and Tank Shark mixing systems are shown in Figure 3-11 and Figure 3-12, respectively. For Reservoir 2, the PAX vendor recommended three mixers spread evenly along the perimeter of the tank while UGSI, the Tank Shark vendor recommended four mixers spread evenly around the perimeter of the tank. For both systems, chemical

dosing would only be on one mixer. The recommended locations for the mixer placement for both the PAX and Tank Shark mixing systems are shown in Figure 3-13 and Figure 3-14, respectively.

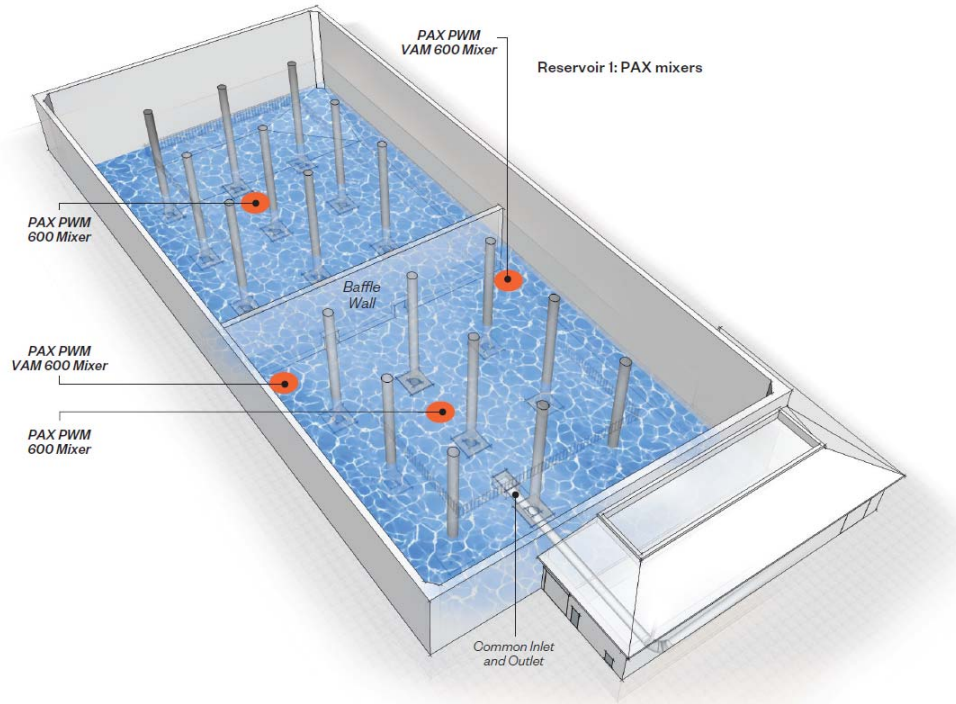

**Figure 3-11. Reservoir 1 Proposed PAX Mixing System Layout**

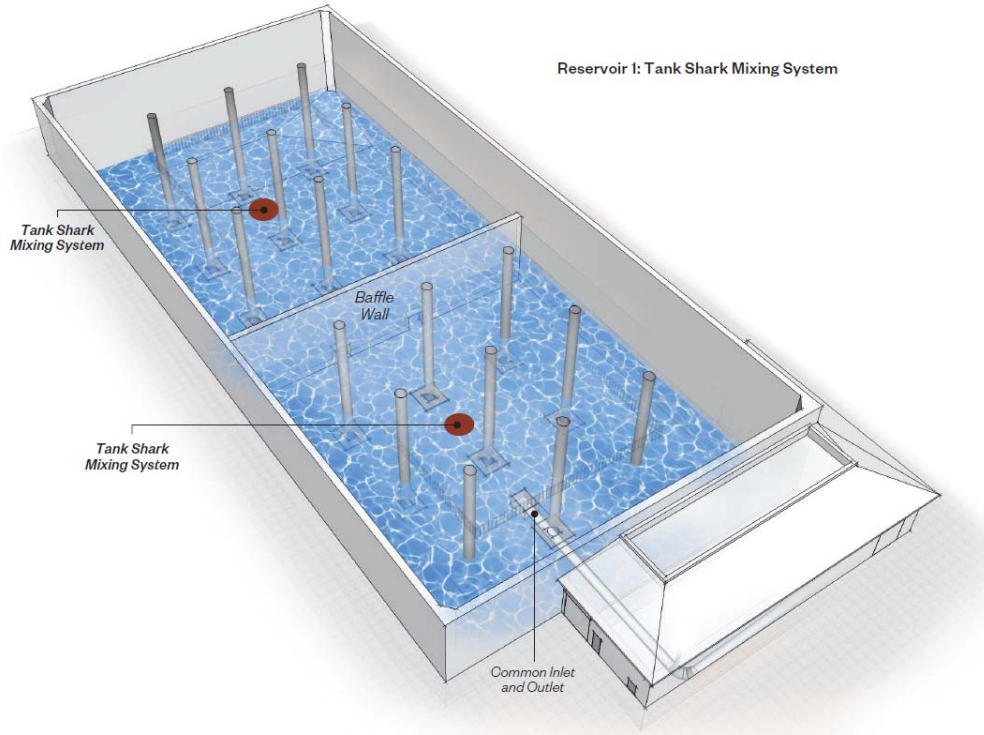

Figure 3-12. Reservoir 1 Proposed Tank Shark Mixing System Layout

Reservoir 2: Underground tank

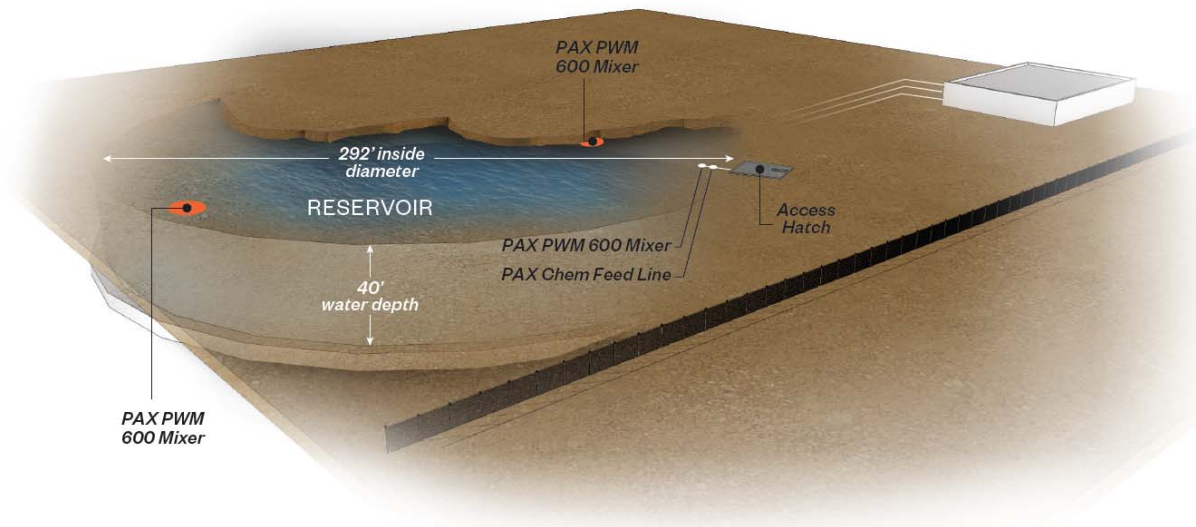

Figure 3-13. Reservoir 2 Proposed PAX Mixing System Layout



Reservoir 2: Underground tank

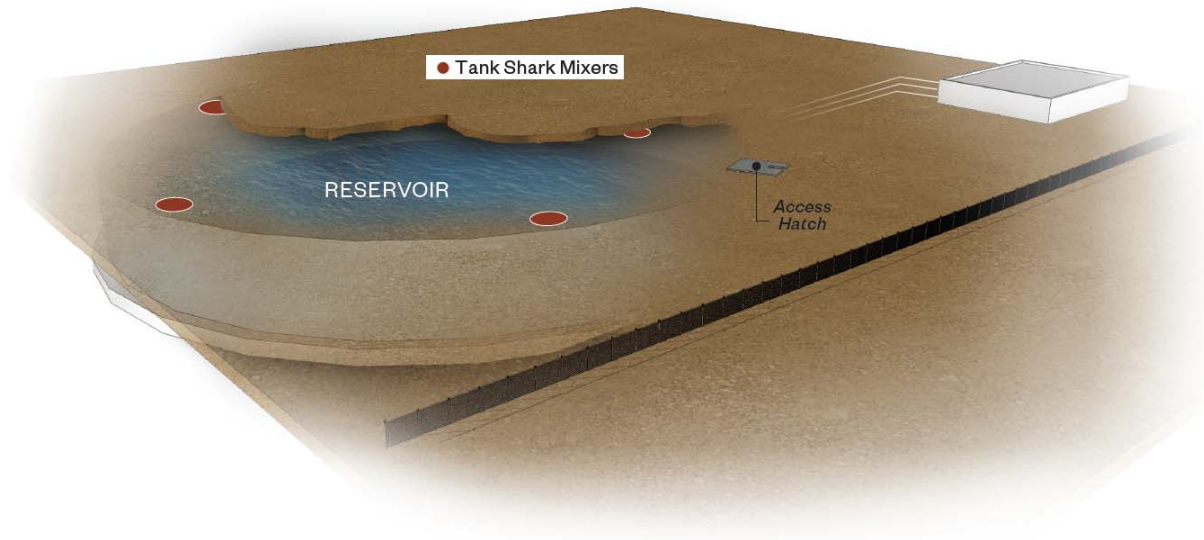

Figure 3-14. Reservoir 2 Proposed Tank Shark Mixing System Layout

## 4. Site Development

### 4.1 Existing Site Layouts

#### 4.1.1 Reservoir 1

As shown in the Civil Site Plan C-100 for Reservoir 1, included in the 30% construction drawings in Appendix B, the project site for Reservoir 1 is a large parcel on the west side of Placentia Avenue, approximately 600 feet north of W 19th Street, bounded to the east by Placentia Avenue, to the north and south by commercial business parks and to the west by residential property. The property parcel is rectangular in shape and measures approximately 450 feet in the east-west direction and 350 feet in the north-south direction. The property is protected on all sides but the east by concrete masonry unit (CMU) security walls, and on the east by Placentia Avenue. The property can be accessed by one of two security gates on Placentia Avenue at either the north or south corners of the site, or through an alley off W 19th Street running parallel to Placentia Avenue at the south-west corner of the site.

Reservoir 1 is a 10 MG rectangular reservoir, oriented in the east-west direction, sitting on the north-east corner of the project site and measuring approximately 263 feet in length by 132 feet in width. The reservoir is situated on a crowded site, also housing a pump house that contains a booster pump station, two operations buildings, a parking structure, and several operations vehicle and equipment storage and maintenance buildings. Both operations buildings and the parking structure are located directly south of the reservoir. The pump house is attached to the reservoir on its west side, and the vehicle and equipment buildings and areas occupy the west side of the site.

The small equipment port building is situated directly to the west of the pump house, and adjacent to the small equipment port on the south are two storage areas for soil. Bounding the north-west side of the site is the large equipment port building. The available space between the pump house and small equipment port, and the reservoir and the large equipment port, are used by the District for parking of operations vehicles. To the north of the reservoir there is a 14 foot wide access road which provides access to the north side of the reservoir and the small access gate on Placentia Avenue.

#### **4.1.2 Reservoir 2**

As shown in the Civil Site Plan C-200 for Reservoir 2 included in the 30% construction drawings in Appendix C the project site for Reservoir 2 consists of two parcels in the square block bounded by Orange Avenue and Westminster Avenue on the north and south, and 23<sup>rd</sup> Street and E Wilson Street on the east and west. Reservoir 2 is located on the larger of the two parcels, situated in the center of the block, surrounded by residential housing on the south and east sides, and by the Lindbergh School on the north and west sides. The booster pump station for Reservoir 2 is located on the smaller of the two parcels, just west of the corner of Orange Avenue and E Wilson Street, and measuring approximately 120 feet in width by 185 feet in length.

Reservoir 2 is an 18 MG buried, circular reservoir. The reservoir is situated in the center of the block and is located beneath the Lindbergh Park. Due to the site's use as a park, minimal elements typical of a reservoir site are present, with only two vents and a small boat access hatch being present above grade.

The booster pump station site consists primarily of the booster pump station building, centered on the west side of the site, as well as a large fuel storage tank and radio tower to the north, and several vaults located throughout the site. The property is protected on the north and west sides by CMU security walls and on the south, east and west by CMU retaining walls. The CMU walls are topped with wrought iron security fencing. The property can be accessed by either a security gate located on Orange Avenue or by a security gate on the south side of the booster pump station site which connects the booster pump station site to the park site.

## **4.2 Proposed Improvements**

As discussed in Sections 2 and 3, Hazen is recommending implementation of chemical storage and metering facilities, as well as improved mixing equipment and residuals monitoring and controls at both reservoirs. The addition of this equipment will allow Mesa Water the ability to more closely monitor and control water chemistry within the reservoirs. The following subsections outline specific site and facility improvements required at each reservoir site to implement the recommended systems.

A list of the major equipment that the chemical storage and metering facilities will be comprised of includes:

- Sodium Hypochlorite Storage Tank
- Sodium Hypochlorite Metering Pump Skid

- Ammonia Storage Tank
- Ammonia Metering Pump Skid
- Water Quality Monitoring and Control Equipment
- Reservoir Mixing System

Alternative site configurations were evaluated at both Reservoir 1 and Reservoir 2 sites taking into consideration space constraints, conflicts with existing utilities, minimizing site improvements, chemical deliveries and ease of operation. The optimal configuration(s) for both reservoir sites are presented in the sections that follow.

#### **4.2.1 Reservoir 1**

At Reservoir 1, it is recommended that the chemical storage and metering facility be located adjacent to the small equipment port, which is directly west of the pump house as shown in Figure 4-1. The corridor available between the pump house building and the small equipment port is approximately 46 feet. The corridor between these two buildings currently serves as a parking location and an access point to the pump house for operations vehicles and service trucks. This corridor also allows operations vehicles to pass the pump house building and access the north side of the reservoir. The new equipment pad will leave adequate space available within the corridor to continue to serve as an access point for both the pump house and the reservoir. However, the District currently uses the space adjacent to the small equipment port for parking of operations vehicles. The chemical storage and metering facility will occupy this space and approximately two parking spaces will no longer be available. Drawing C-100 in Appendix C illustrates the reservoir, pump house, small equipment port and proposed location of the chemical storage and metering facility.



**Figure 4-1. Reservoir 1 Site Layout of Proposed Chemical Feed Facility**

The space between the small equipment building and the pump house, in addition to acting as an access corridor, is also a drainage channel. The grade adjacent to both buildings slopes downward into a swale between the two buildings. Placement of the new chemical storage and metering facility will interfere with the location of the existing swale. The swale will be realigned around the new equipment pad, at the same elevations as the existing swale, in order to maintain stormwater routing through the site. This realignment will require additional asphalt demolition, grading and paving around the new equipment pad. Drawing C-101 illustrates the proposed asphalt demolition boundaries, grading and paving requirements.

Reservoir 1 will employ two separate chemical feed points, one for each chamber of the reservoir. Both sodium hypochlorite and ammonia will be delivered via 1/4-inch tube contained in 1-inch pipe, therefore requiring four separate 1-inch chemical containment pipes to be run from the chemical storage and metering facility through the site to the reservoir. Drawing C-102 illustrates the proposed double-contained chemical feed piping.

The sodium hypochlorite and ammonia storage areas will have sumps within their containment that will drain to a storm drain catch basin north of the facility. This is the same configuration as the Well Automation Project Sites. The drains will be used for disposing of nuisance water that builds up inside of the containment areas. The drains will be equipped with valves that will normally remain closed, allowing any chemical spills to be contained and pumped out, rather than draining to the storm drain. When combined, sodium hypochlorite and ammonia generate potentially noxious gases. Separate drains from the sodium hypochlorite and ammonia storage areas will be run to the storm drain catch

basin to ensure that in the unlikely event of coinciding spills, which inadvertently drain from the containment areas, there is no potential for chemical reactions. Drawing C-102 in Appendix C illustrates the containment area drain piping. Drawing M-100 and M-101 in Appendix C illustrate the layout of the chemical storage and metering facility.

#### 4.2.2 Reservoir 2

At Reservoir 2, the south side of the booster station site is recommended for siting of the chemical facility as shown in Figure 4-2. The new facility will sit adjacent to the retaining wall that serves as the booster station site boundary. The site selection leaves adequate space between the facility and the retaining wall to avoid interfering with operation of the access gate located in the southeast corner of the site, and is far enough from the retaining wall to avoid interference with its foundation during construction of the new facility.



Figure 4-2. Reservoir 2 Site Layout of Proposed Chemical Feed Facility

The recommended location avoids site improvements beyond those required for the new facility because there are no impacts to drainage or access to the booster station or other equipment located on site. A vehicle access corridor of approximately 22 feet will be available to allow operations and service

vehicles access to the new equipment for deliveries and maintenance. Drawing C-200 in Appendix C illustrates the reservoir, pump station, retaining wall that bounds the site and proposed location of the chemical storage and metering facility. Drawing C-201 in Appendix C illustrates the proposed asphalt demolition boundaries to accommodate the new chemical storage and metering facility.

Reservoir 2 will employ one chemical feed point, circulated by three mixers. Both sodium hypochlorite and ammonia will be delivered via ¼-inch tube contained in 1-inch pipe, requiring two separate 1-inch chemical containment pipes to be run from the chemical storage and metering facility through the park to the reservoir. Drawing C-202 in Appendix C illustrates the double-contained chemical feed piping.

The sodium hypochlorite and ammonia storage areas will have sumps within their containment that will drain to a storm drain catch basin north of the facility. The drains will be used for disposing of nuisance water that builds up inside of the containment areas. The drains will be equipped with valves that will be normally closed, allowing any chemical spill to be contained and pumped out, rather than draining to the storm drain. When combined, sodium hypochlorite and ammonia generate gases. Separate drains from the sodium hypochlorite and ammonia storage areas will be run to the storm drain catch basin to ensure that in the unlikely event of coinciding spills, which inadvertently drain from the containment areas, there is no potential for chemical reactions. Drawing C-202 in Appendix C illustrates the containment area drain piping. Drawing M-200 and M-201 included in Appendix C illustrate the layout of the chemical storage and metering facility.

## **5. Electrical, Instrumentation and Controls**

### **5.1 Electrical**

#### **5.1.1 Reservoir 1**

Reservoir 1 is supplied by two (2) 480V, 3-Phase, 4-Wire, electric utility services. One service enters the property from the north and powers the Pump House via a 400A “Service Switchboard” located outside of the Heavy Equipment Port. The “Service Switchboard” supplies Motor Control Center “PH-A” which serves as the main distribution for the Pump House.

The second electric utility service, the main service, enters the property from the south and powers the remainder of the facility. The main service supplies a 600A Main Switchboard “MS” located in the Operations Building Electrical Room. Main Switchboard “MS” then supplies Distribution Panel “DG” via an automatic transfer switch. Panel “DG” serves as the main distribution for the Operations Building and supplies Distribution Panel “DF” via an automatic transfer switch. Panel “DF” is located in the Field Service Center Electrical Room and serves as the main distribution for the Field Service Center.

There are two (2) 150kW standby power generators located in the Pump House. One generator is connected to the automatic transfer switch supplying Distribution Panel “DG” and the second generator is connected to the automatic transfer switch supplying Distribution Panel “DF”. If standby power is required to supply the proposed chemical feed equipment and tank mixers, then it is recommended to power the equipment from Distribution Panel “DF”, one of its sub-panels, or from a new subpanel powered by “DF”. However, further information is required to determine if Distribution Panel “DF” and its associated generator have adequate capacity to supply the new loads.

### **5.1.2 Reservoir 2**

Reservoir 2 is supplied by two (2) 480V, 3-Phase, 4-Wire, electric utility services which both enter the property from the north. One service powers the two (2) 100 HP pumps via a 300A main breaker in a service entrance switchboard. These pumps are no longer in operation and this electric utility service is not currently utilized.

The second electric utility service powers the remainder of the facility. This service supplies a 600A main breaker in a service entrance switchboard, which then supplies a 600A motor control center. The motor control center serves as the main distribution for the site. The motor control center supplies Panel “PE” via a 100A automatic transfer switch and 75kVA stepdown transformer which steps the voltage down to 120/208V.

There is one (1) 45kW standby power generator located in the pump station. The generator is connected to the automatic transfer switch supplying Panel “PE” via the stepdown transformer. If standby power is required to supply the proposed chemical feed equipment and tank mixers, then it is recommended to power the equipment from Panel “PE”. However, further information is required to determine if Panel “PE” and its associated generator have adequate capacity to supply the new loads. If 480V power is required for the new equipment, then the standby power system will need to be reconfigured.

## **5.2 SCADA**

The new mixers and chemical feed system equipment will be integrated into Mesa Water®’s existing SCADA system. At Reservoir 1, the new equipment will be integrated into existing RTU-30. At Reservoir 2, the new equipment will be integrated into existing RTU-32. Further evaluation is required to determine the modifications necessary to integrate the new equipment into the existing RTUs.

## **6. Construction Issues, Permits, Schedules and Construction Documentation**

### **6.1 List of Permits and Requirements**

Table 6-1 presents a summary of the agency and municipal permit requirements and approvals required for the improvements to the chemical systems at Reservoirs 1 and 2.

**Table 6-1. Permit Requirements Summary**

Issuing Agency Information	Permit/Approval
<p><b>Costa Mesa Fire Department</b> Michelle Rudaitis -Hazardous Materials Specialist michelle.rudaitis@costamesaca.gov Phone: (714) 327-7402 Fax: (714) 327-7408</p>	<p>Disclosure Packet and Chemical Classification Review</p>
<p><b>California Department of Public Health (CDPH)</b> Field Operations Branch Santa Ana District 605 W. Santa Ana Blvd Bldg 28, Rm. 325 Santa Ana, CA 92701 (714) 558-4410</p>	<p>Review of plans, approval letter if plans deviate from California water standards</p>
<p><b>State Water Resources Control Board Division of Water Quality</b> Storm Water Section 1001 I Street Sacramento, CA 95814 (916) 341-5537</p>	<ul style="list-style-type: none"> <li>• NPDES General Construction Activities Storm Water Permit – Submit of Notice of Intent (NOI) form for construction activities that disturb one acre or more of soil. <i>Estimate of disturbed area is less than one-acre, so permit will not be required.</i></li> </ul>

## 6.2 Recommendations for Construction Phasing and Schedule

Based on similar projects, it is estimated that it will take approximately 11 months for final design, bidding, shop drawing review, equipment procurement, and installation and start-up of the Chemical Storage and Dosing Facilities. Upon completion of the final design based on Mesa Water’s schedule, a detailed construction schedule will be prepared as part of the final design submittal.

## 6.3 Drawing List

Hazen and our subconsultant Brady and Associates have prepared a list of the drawings for the proposed improvements. These include general plans, civil, mechanical, structural, electrical, instrumentation/control plans and the associated details. Table 6-2 presents our list of proposed construction drawings.



**Table 6-2. Construction Drawing List**

Sheet No.	Drawing No.	Sheet Title
1	G-1	Title Sheet
2	G-2	Location Map, Vicinity Map, and Sheet Index
3	G-3	General Notes, Abbreviations, and Symbols
4	C-1	Site Plan Reservoir 1
5	C-2	Yard Piping Plan - Reservoir 1
6	C-3	Site Plan Reservoir 2
7	C-4	Yard Piping Plan - Reservoir 2
8	C-5	Civil Details - 1
9	C-6	Civil Details - 2
10	C-7	Civil Details - 3
11	DS-1	Structural Notes
12	DS-3	Structural Details 1
13	DS-4	Structural Details 2
14	S-1	Floorplan Reservoir 1
15	S-2	Sections – Reservoir 1
16	S-3	Architectural Details –Reservoir 1
17	S-4	Floorplan –Reservoir 2
18	S-5	Sections – Reservoir 2
19	S-6	Architectural Details – – Reservoir 2
20	M-1	Mechanical Standard Symbols
21	M-2	Reservoir 1 Chemical Facilities Plan
22	M-3	Reservoir 1 Chemical Facilities Section-1
23	M-4	Reservoir 1 Chemical Facilities Section-2
24	M-5	Reservoir 2 Chemical Facilities Plan
25	M-6	Reservoir 2 Chemical Facilities Section-1
26	M-7	Reservoir 2 Chemical Facilities Section-2
27	M-8	Mechanical Details - 1
28	M-9	Mechanical Details - 2
29	M-10	Mechanical Details - 3
30	E-1	Standard Electrical Symbols and Abbreviations
31	E-2	Electrical Site Plan - Reservoir 1
32	E-3	Single Line Diagram and Elevations – Reservoir 1
33	E-4	Electrical Site Plan - Reservoir 2
34	E-5	Single Line Diagram and Elevations – Reservoir 2
35	E-6	Chemical Facilities Power and Signal Plan
36	E-7	Chemical Facilities Lighting and Receptacle Plan
37	E-8	Schedules 1

Sheet No.	Drawing No.	Sheet Title
38	E-9	RTU Diagram 1
39	E-10	RTU Diagram 2
40	E-11	RTU Diagram 3
41	E-12	RTU Diagram 4
42	E-13	RTU Diagram 5
43	E-14	RTU Layout
44	E-15	Details
45	I-1	Process and Instrumentation Symbols and Abbreviations
46	I-2	Sodium Hypochlorite Feed System
47	I-3	Aqueous Ammonia Feed System
48	I-4	Process Flow Diagram

## 6.4 Specifications List

Hazen has prepared a list of the anticipated technical specifications that will be developed during final design. The necessary specification sections are in Table 6-3:

**Table 6-3. Construction Specification List**

Specification No	Title
<b>Division 0</b>	
Provided by Mesa Water® District	
<b>Division 1</b>	
01010	Summary of Work
01015	Owner Furnished Equipment and Services
01040	Coordination
01140	Work Restrictions
01200	Project Meetings
01300	Submittals
01350	Seismic Anchorage and Bracing
01400	Quality Control
01450	Special Inspections
01520	Maintenance of Utility Operations During Construction
01530	Protection of Existing Facilities
01540	Demolition and Removal of Existing Structures and Equipment
01550	Site Access and Storage
01600	Materials and Equipment
01650	Equipment Testing and Plant Startup
01700	Project Closeout

Mesa Water® District  
Reservoirs 1 & 2 Pumps, Control, and Chemical System Assessment

Specification No	Title
<b>Division 2 - Site Construction</b>	
02050	Demolition
02200	Earthwork
02207	Aggregate Materials
02214	Flowable Fill
02510	Paving and Surfacing
<b>Division 3 - Concrete</b>	
03100	Concrete Formwork
03200	Reinforcing Steel
03250	Concrete Accessories
03290	Joints in Concrete
03300	Cast-In-Place Concrete
03350	Concrete Finishes
03370	Concrete Curing
03732	Concrete Repairs
<b>Division 5 - Metals</b>	
05010	Metal Materials
05035	Galvanizing
05050	Metal Fastening
05061	Stainless Steel
05120	Structural Steel
05140	Structural Aluminum
05500	Metal Fabrications
05510	Metal Stairs
05515	Ladders
<b>Division 6 - Wood and Plastics</b>	
06610	Glass Fiber and Resin Fabrications
<b>Division 7 - Thermal and Moisture Protection</b>	
07190	Vapor Barrier
<b>Division 9 - Finishes</b>	
09900	Painting
<b>Division 10 - Specialties</b>	
10400	Identifying Devices
10524	Emergency Shower-Eyewash Station
10525	Chemical Handling Safety Equipment
10535	Canopies
<b>Division 11 - Equipment General Provisions</b>	
11000	Equipment General Provisions

Mesa Water® District  
Reservoirs 1 & 2 Pumps, Control, and Chemical System Assessment

Specification No	Title
11100	Pumps, General
11170	Liquid Chemical Metering Pumps
11240	Vertical Turbine Mixers
<b>Division 13 - Special Construction</b>	
13121	Metal Buildings
13207	Polyethylene Storage Tanks
13209	Fiberglass Reinforced Plastic Storage Tanks
<b>Division 15 - Mechanical</b>	
15000	Basic Mechanical Requirements
15008	PVC, CVPC Pipe
15010	Copper Pipe
15012	Steel Pipe
15020	Pipe Supports
15030	Piping and Equipment Identification Systems
15095	Valves, General
15100	Valve Operators and Electric Valve Actuators
15101	Butterfly Valves
15104	Ball Valves
15105	Check Valves
15109	Plug Valves
15111	Altitude Valves
15114	Miscellaneous Valves
15115	PVC, CPVC Valves
15140	Supports and Anchors
15170	Low Voltage Electric Motors
15390	Schedules
15391	Heat Tracing Systems
15400	Overall Plumbing Master
15430	Plumbing Specialties
15440	Plumbing Fixtures
15450	Plumbing Equipment
<b>Division 16 - Electrical</b>	
16000	Basic Electrical Requirements
16111	Conduit
16118	Underground Electrical
16123	Low Voltage Wire and Cable
16130	Boxes
16141	Wiring Devices

Mesa Water® District  
Reservoirs 1 & 2 Pumps, Control, and Chemical System Assessment

Specification No	Title
16170	Grounding and Bonding
16190	Supporting Devices
16195	Electrical - Identification
16280	Surge Protective Devices
16426	Low Voltage Switchboards
16440	Disconnect Switches
16470	Panelboards
16482	Low Voltage Motor Control Centers
16495	Low Voltage Variable Frequency Drive Systems
16500	Lighting
16902	Electrical Controls and Relays
<b>Division 17 - Control and Information Systems</b>	
17000	Control and Information System Scope and General Requirements
17030	Control and Information System Submittals
17040	Control and Information System Training Requirements
17050	Tools, Supplies and Spare Parts, General
17060	Signal Coordination Requirements
17070	Control and Information System, General
17071	Factory Acceptance Test
17072	Field Testing
17073	Final Acceptance Test
17080	Quality Assurance
17100	Control and Information System Hardware, General
17120	Programmable Logic Controllers and Programmable Operator Interfaces
17125	PLC Operator Interface Units
17180	Local Area Network
17190	Uninterruptible Power Systems
17200	Control and Information System Software Requirements
17500	Enclosures, General
17510	Cabinets and Panels
17512	Cabinet Air Conditioning Units
17520	Field Panels
17550	Panel Instruments and Accessories
17560	Surge Protection Devices
17600	Unpowered Instruments, General
17650	Pressure Gauges
17670	Level Switches (Float Suspended)
17698	Instrumentation and Control System Accessories

Specification No	Title
17700	Powered Instruments, General
17740	Ultrasonic Level Instruments
17760	Pressure Indicating Transmitters
17800	Analytical Instruments, General
17801	pH Analyzers
17831	Chlorine Analyzers
17833	Ammonia - Monochloramine Analyzers
17834	On-Line Chloramination Analyzer
17900	Schedules and Control Descriptions, General
17910	Instrument Schedule
17920	Control System Input/Output Schedule
17950	Functional Control Descriptions

## 6.5 Opinion of Probable Construction Costs

A summary of the engineer’s estimate of probable construction costs for improvements to the chemical feed systems for the various reservoir management systems evaluated for Reservoir 1 and Reservoir 2 are summarized in Tables 6-4 and 6-5 respectively. The cost estimate is an AACE level 4 cost estimate based on the information presented in this preliminary design report. As shown in Appendix D, for Reservoirs 1 and 2 respectively, the comparative estimates include a 20% markup for general conditions to reflect the unknowns at this preliminary stage of the design, 10% for contractors overhead and profit, 3% annual escalation with a 6 month construction duration, bonding and insurance, 15% for engineering and construction support services and a 30% contingency reflective of the level of engineering that has been completed. A detailed breakdown of the costs for each reservoir by discipline and the assumptions are also provided in Appendix D.

**Table 6-4. Engineer's Estimate of Probable Construction Costs – Reservoir 1**

Description	Probable Construction Cost		
	PAX Mixer	Tank Shark	Vortex Mixer
Construction/Equipment Cost	\$975,043	\$855,861	\$843,308
15% Engineering and Construction Support Services	\$146,256	\$128,379	\$126,496
Subtotal	\$1,121,299	\$984,240	\$969,804
30% Contingency	\$336,389	\$295,272	\$290,941
<b>Total</b>	\$1,457,689	<b>\$1,279,512</b>	\$1,260,745

Notes:

1. Cost estimates include the upsized chemical storage tanks and infrastructure and containment to support larger chemical storage
2. Cost does not include legal or administrative costs
3. Estimate based on level of engineering

**Table 6-5. Engineer's Estimate of Probable Construction Costs – Reservoir 2**

Description	Probable Construction Cost		
	PAX Mixer	Tank Shark	Vortex Mixer
Construction/Equipment Cost	\$837,949	\$771,415	\$788,264
15% Engineering and Construction Support Services	\$125,692	\$115,712	\$118,240
Subtotal	\$963,641	\$887,127	\$906,504
30% Contingency	\$289,092	\$266,138	\$271,951
<b>Total</b>	<b>\$1,252,734</b>	<b>\$1,153,265</b>	<b>\$1,178,455</b>

Notes:

1. Cost estimates include the upsized chemical storage tanks and infrastructure and containment to support larger chemical storage
2. Cost does not include legal or administrative costs
3. Estimate based on level of engineering

## 7. Recommendations

To address water quality issues being experienced within Mesa Water’s existing Reservoirs 1 and 2, we recommend retrofitting the two existing reservoirs, Reservoirs 1 and 2 with chemical feed and monitoring equipment with the capabilities to ensure that the potable water quality standards are being met at each of the reservoir sites. Equipment shall include chemical storage tanks that will provide approximately one-month supply of 19% (by weight) aqueous ammonia (ammonia) and 12.5% (by weight) sodium hypochlorite, metering pumps, chemical injection equipment, in-tank mixing systems and residual disinfection analyzers that provide direct and consistent monitoring capabilities. A summary of our recommendations is shown in Table 7-1. It should be noted that to be consistent with Mesa Water’s Well Automation Project and to minimize chemical deliveries during the peak summer months, the larger chemical storage tanks have been specified. However, during final design, it is recommended that a degradation analysis at Mesa Water’s Well No 7 site, which has a 900 gallon sodium hypochlorite tank, be conducted to confirm that perchlorates are not forming during the winter months due to the age of the chemicals in the tank. Should the analysis show that the sodium hypochlorite is degrading and perchlorates are forming, the smaller chemical storage tanks shall be installed. In addition, CFD modeling is recommended to confirm number and location of the mixers, location for chemical injection and water quality sampling. It is also recommended that a reevaluation of the flows in and out of the reservoirs based on the most recent annual flow data be conducted to confirm the size of the chemical storage tanks and chemical feed pumps. Sizing and operation of the chemical storage and feed systems should also take into consideration the recommendation in TM-3 to seasonally lower the water levels in Reservoir 1.

**Table 7-1. Recommended Chemical Storage and Feed Equipment Improvements**

Equipment	Reservoir 1	Reservoir 2
<b>Chemical Feed System – Sodium Hypochlorite</b>		
- Tank Size <sup>1</sup>	500 gallon fiberglass tank	900 gallon fiberglass tank
- Metering Pump	Diaphragm Metering Pump <sup>2</sup> (2 duty + 2 standby)	Diaphragm Metering Pump <sup>3</sup> (1 duty + 1 standby)
- Feed Rate	8 gph with 100:1 turndown	15 gph with 100:1 turndown
<b>Chemical Feed System – Ammonia</b>		
- Tank Size	100 gallons XLPE or HDLPE Tank	200 gallons XLPE or HDLPE Tank
- Metering Pump	Diaphragm Metering Pump (1 duty + 1 standby)	Diaphragm Metering Pump (1 duty + 1 standby)
- Feed Rate	3 gph with 10:1 turndown	3 gph with 10:1 turndown
<b>Mixers</b>		
- Model/ Number of Mixers	Tank Shark RMS / 2	Tank Shark RMS / 4
<b>Electrical</b>	Power from Distribution Panel “DF”	Power from Distribution Panel “PE”
<b>SCADA</b>	New equipment is integrated into existing RTU-30	New equipment is integrated into existing RTU-32

<sup>1</sup> Chemical storage tank sizes to be reevaluated during final design following analysis of sodium hypochlorite degradation/perchlorate formation at Mesa Water’s Well No 7.

<sup>2</sup> Based on Maximum in flow of 7000 gpm. Increase residual from 1.5 mg/L to 2.5 mg/L with ability to dose at 2.5 mg/L

<sup>3</sup> Based on Maximum in flow of 11,600 gpm. Increase residual from 1.5 mg/L to 2.5 mg/L with ability to dose at 2.5 mg/L



[This page is intentionally left blank.]

## **Appendix A - Reservoir Mixing Systems**

1. Tank Shark – Drawings and Budgetary Estimates
2. PAX Mixer – Drawings and Budgetary Estimates
3. Vortex – Drawings and Budgetary Estimates

[This page is intentionally left blank.]

# **A-1. Tank Shark Mixer – Drawings and Budgetary Estimates**

[This page is intentionally left blank.]

NON-CONTROLLED COPY  
 INFORMATION SUBJECT TO CHANGE WITHOUT NOTICE  
 VERIFY REV LEVEL OF PAPER COPY WITH REV LEVEL ON PPC WEB SITE

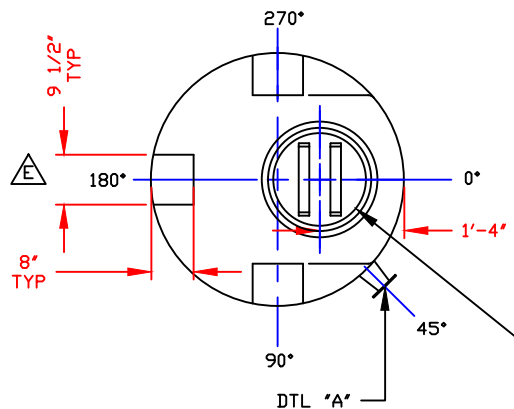

  
 STANDARD COVER:  
 17" CAP/BUTTRESS THR'D  
 BLACK PE  
 STOCK NO. 4558

NOZZLE SCHEDULE & ACCESSORIES					
SERVICE	MK	STOCK NO.	SIZE	FITTING	DEG ELEV

TO BE USED WITH SPLIT BACK-UP RING & COMPANION FLG.--AVAILABLE IN 2" SIZE ONLY

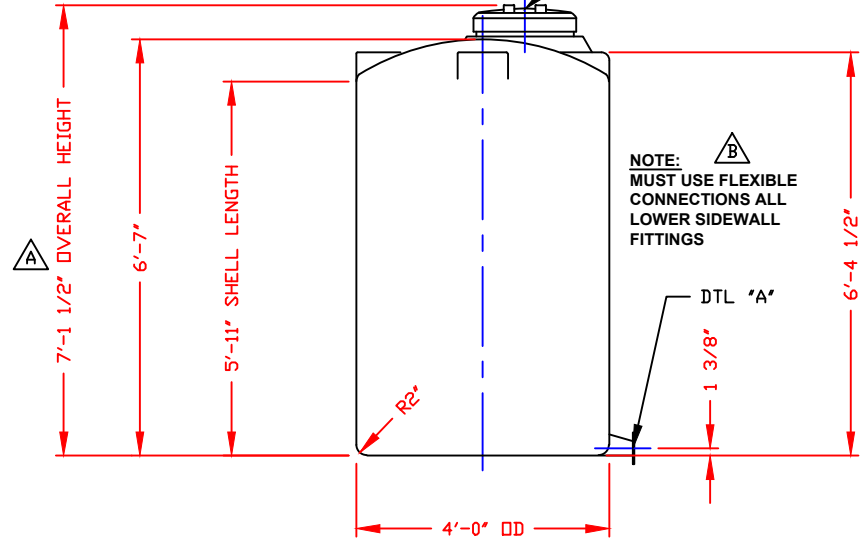
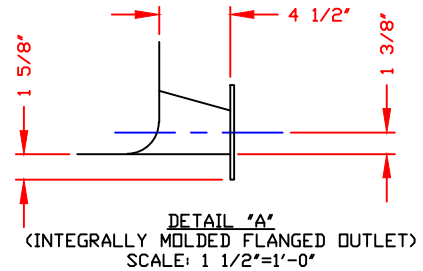

- NOTES:
- THIS IS A COMPUTER GENERATED DWG. DO NOT REVISE BY HAND.
  - DIMENSIONS WILL VARY ±3% DUE TO VARIATIONS IN MULTIPLE MOLDS & CONDITIONS PREVALENT DURING MANUFACTURE & USAGE.
  - MOLDED IN GALLONAGE MARKERS IN MANWAY AREA IN 50 GAL INCREMENTS UP TO 550 GAL.

CALCULATED CAPACITIES/ VOLUME IN U.S. GALLONS		
DESIGN CAP	DOME VOL	TOTAL VOL
547	25	572

CONFIDENTIAL PROPERTY OF  
 PDLY PROCESSING COMPANY  
 NOT FOR REPRINT OR USE  
 WITHOUT PERMISSION

REV 'E' ADDED FTG FLATS TO DOME BY:JB 1/7/13 CK:WM
REV 'D' REVISED COVER BY:JB 7/26/09 CK:WM
REV 'C' REVISED LID BY:MBW 3/3/03 CK:JB
REV 'B' ADDED FITTING NOTE BY:MBW 3/3/03 CK:JB
REV 'A' ADDED DIMENSION BY:JB 10/8/02 CK:MBW

DWG TITLE			
545 GALLON IMFO TANK			
SCALE:	1/2"=1'-0"	 Central Region P.O. Box 4189 Grand 25th St, Shreveport, LA 71205 (504) 343-7825 FAX (504) 343-9795	DR:
DATE:	11/8/99		CK:
SHEET		COMPUTER FILE	REV
1 OF 1		1100545	E

[This page is intentionally left blank.]

## **BUDGET PROPOSAL**

# **MONOCLOR™ CHLORAMINE MANAGEMENT SYSTEM FOR MESA WATER DISTRICT, CA RESERVOIR 1 & 2**



Process Solutions, Inc. File No.: P16-2781 (Rev 1)  
CA Contractor's License: #877235

Prepared on: February 3, 2017

**SALES REPRESENTATIVE**

UGSI Chemical Feed, Inc./Process Solutions, Inc.

Kevin Sanner

1077 Dell Ave, Suite A

Campbell, CA 95008

Tel: (310) 975-9719

Email: [ksanner@ugsicorp.com](mailto:ksanner@ugsicorp.com)



February 3, 2017

Ms. Tama Snow, P.E.  
Hazen & Sawyer Consultants  
7700 Irvine Center Drive, Suite 200, Irvine, CA 92618

Re: Monoclor™ Chloramine Management System for Mesa Consolidated, CA  
Process Solutions, Inc. File No.: P16-2781(Rev 1)

Dear Tama,

Thank you for your interest in Process Solutions, Inc. (PSI), a UGSI Solutions company. We have prepared this budgetary proposal for providing two (2) Monoclor™ Chloramine Management Systems for Mesa Water District, CA. Our proposal is based on the following design criteria:

Design Criteria (Reservoir #1)

Reservoir Dimensions, ft	265 L x 132 W x 22 H
Maximum Capacity, gal	10,000,000

Design Criteria (Reservoir #2)

Reservoir Diameter, ft	296.5
Reservoir Height, ft	36
Maximum Capacity, gal	20,000,000

Our mixing system is a unitary piece of equipment. The simple unit only consists of a patented mixing nozzles, a chemical injection nozzle and piping, sample tubing, and electropolished stainless steel support base and mast. To make a complete and functional system, a pressurized source of motive water is necessary. An existing water source or a booster pump can be utilized for the motive water. Each system is pre-assembled, piped, and factory-inspected to facilitate simple installation and start-up at the jobsite.

A detailed scope of supply and the budgetary price for the system is listed in Section 1 of this proposal. All pricing is based on our standard system, as outlined in our equipment specifications (available upon request).

Our proposal is for budgetary evaluation purposes only. This budgetary pricing is intended to be a guide based on current costs. A request for updated pricing should be made every six months throughout the project evaluation and design stage in order to keep the project cost estimate accurate and current.

**System Features & Advantages**

The Process Solutions, Inc. Tank Shark® Mixing System incorporates many features and advantages, including:

- No power, pumps, or moving parts within the reservoir
- Improved water quality by eliminating thermal stratification, nitrification, and freezing
- Real time sampling and analysis maintains constant residual



- Constructed of NSF-approved materials
- Construction for simple installation without tank penetrations or entering a confined space
- Unique design allows for continuous self-cleaning of the chemical injection nozzle
- Reliable performance and robust construction reduces the need for operator attention and lowers maintenance costs
- Pre-assembled, piped, and inspected at the factory prior to shipment
- Delivered and installed quickly, with minimum construction and installation cost
- Proven track record supported by years of successful operational experience

Our scope of supply follows in section 1 and our technical information in section 2. Section 3 includes our qualifications and experience and section 4 includes our brochures.

We look forward to working with you on this project. If we can be of any further assistance, please do not hesitate to contact me at (310) 975-9719.

Thank you.

Sincerely,

Kevin Sanner  
Regional Sales Manager

Cc: Allison Petsche, Process Solutions, Inc.

**SECTION 1**

**SCOPE OF SUPPLY**

**Monoclor™ Chloramine Management System**

- A. Reservoir 1 (10MG) - Scope of Work by Process Solutions, Inc.
- B. Reservoir 1 (10MG) - Scope of Work by Others
- C. Reservoir 2 (20MG) - Scope of Work by Process Solutions, Inc.
- D. Reservoir 2 (20MG) - Scope of Work by Others

**A. RESERVOIR 1 - SCOPE OF WORK BY PROCESS SOLUTIONS, INC.**

The following equipment and services are included in our scope of work. All equipment will be manufactured in accordance with our standard equipment. Please see attached equipment general arrangement drawing for illustration and reference.

<b>No</b>	<b><u>Item Description</u></b>	<b><u>Qty.</u></b>
1.	<b>Monoclor™ Control Panel</b> , including: <ul style="list-style-type: none"> <li>▪ NEMA 4X Enclosure – 304 Stainless Steel Construction</li> <li>▪ Allen-Bradley MicroLogix 1400 Programmable Logic Controller (PLC)</li> <li>▪ Ethernet Communication</li> <li>▪ Remote Monitoring Telemetry</li> <li>▪ 6" Color Touchscreen Human-Machine Interface (HMI)</li> <li>▪ 24 VDC Power Supply</li> <li>▪ Emergency Stop Pushbutton</li> <li>▪ Panel-Mounted Disconnect Switch</li> </ul>	1
2.	<b>Hypochlorite Storage Tank</b> , including: <ul style="list-style-type: none"> <li>▪ HDLPE Construction</li> <li>▪ Double-Wall Containment</li> <li>▪ 500 Gallon Capacity</li> <li>▪ Ultrasonic Level Control</li> <li>▪ Top Manway</li> <li>▪ Dimensions: 4'-11"D x 5'-11"H</li> </ul>	1
3.	<b>Ammonia Storage Tank</b> , including: <ul style="list-style-type: none"> <li>▪ HDLPE Construction</li> <li>▪ Ultratainer with Saf-Tainer Containment</li> <li>▪ 220 Gallon Capacity with 485 Gallon Containment</li> <li>▪ Ultrasonic Level Control</li> <li>▪ Top Manway</li> <li>▪ Dimensions: 3'-10"D x 3'-10"H (Tank) 66"W x 66"L x 30"H (Containment)</li> </ul>	1
4.	<b>Tank Shark® Mixing System</b> , including: <ul style="list-style-type: none"> <li>▪ 100 gpm Maximum Volumetric Flow Rate</li> <li>▪ Dual-Nozzle Motive Water Mixing Nozzle Assembly</li> <li>▪ Chlorine Injection Nozzle Assembly</li> <li>▪ Sampling Assembly</li> <li>▪ Bottom Feed Configuration</li> <li>▪ Standard Base</li> <li>▪ Reinforced PVC Water &amp; Hypochlorite Hoses from Tank Shark® to Tank/Reservoir Hatch</li> <li>▪ Polyethylene Sample Tubing from Tank Shark® to Tank/Reservoir Hatch</li> <li>▪ Stainless Steel Tethering Assembly</li> <li>▪ Electropolished 304 Stainless Steel Base and Mast Assembly</li> </ul>	2

<u>No</u>	<u>Item Description</u>	<u>Qty.</u>
5.	<b>Hypochlorite Dosing Skid</b> , including: <ul style="list-style-type: none"> <li>▪ Metering Pump, 10 GPH @ 145 PSI with TEFC Inverter-Duty Motor (Qty. 2)</li> <li>▪ NEMA 4X Variable Frequency Drive (Qty. 2)</li> <li>▪ Calibration Column (Qty. 1)</li> <li>▪ Pressure Relief Valve (Qty. 2)</li> <li>▪ Backpressure Valve (Qty. 2)</li> <li>▪ Pulsation Dampener (Qty. 2)</li> <li>▪ Wye Strainer (Qty. 1)</li> <li>▪ Pressure Gauge (Qty. 2)</li> <li>▪ Flow Verification Sensor (Qty. 2)</li> </ul> <b>Note: Dosing Pumps to Be Mounted on a Pre-Plumbed PVC Skid.</b>	1
6.	<b>Ammonia Dosing Skid</b> , including: <ul style="list-style-type: none"> <li>▪ Metering Pump, 2.4 GPH @ 87 PSI with TEFC Inverter-Duty Motor (Qty. 2)</li> <li>▪ Calibration Column (Qty. 1)</li> <li>▪ Pressure Relief Valve (Qty. 2)</li> <li>▪ Backpressure Valve (Qty. 2)</li> <li>▪ Pulsation Dampener (Qty. 2)</li> <li>▪ Wye Strainer (Qty. 1)</li> <li>▪ Pressure Gauge (Qty. 2)</li> <li>▪ Flow Verification Sensor (Qty. 2)</li> </ul> <b>Note: Dosing Pumps to Be Mounted on a Pre-Plumbed PVC Skid.</b>	1
7.	<b>Stainless Steel Vertical Turbine Booster Pump</b> , including: <ul style="list-style-type: none"> <li>▪ 7.5 HP EAct-Efficiency, TEFC Motor</li> <li>▪ 25 HP NEMA 1 Variable Frequency Drive</li> <li>▪ NEMA 3R VFD Enclosure</li> </ul>	2
8.	<b>Flow Meter</b> <ul style="list-style-type: none"> <li>▪ Magnetic Flow Meter for Water Line</li> </ul>	2
9.	<b>Chlorine Analyzer</b> <ul style="list-style-type: none"> <li>▪ Magnetic Flow Meter for Water Line</li> </ul>	1
10.	<b>Analyzer Sample Pump</b> <ul style="list-style-type: none"> <li>▪ Mag Drive, 1 GPM</li> </ul>	1
11.	<b>Installation of Monoclor™ System</b> , including <ul style="list-style-type: none"> <li>▪ Installation of Tank Shark® Systems</li> <li>▪ Tank Penetrations</li> <li>▪ Plumbing between equipment</li> <li>▪ Piping as shown on drawings</li> <li>▪ Installation materials including interconnecting piping, tubing,</li> </ul>	Included

<u>No</u>	<u>Item Description</u>	<u>Qty.</u>
	<ul style="list-style-type: none"> <li>▪ valves, and strut</li> </ul>	
12.	<b>Manufacturer's Services for Installation Inspection, System Start-Up, and Operator Training (3 Days at the Jobsite)</b>	Included
13.	<b>Design Submittal and Operation &amp; Maintenance Manual as Follows</b>	Included
	<ul style="list-style-type: none"> <li>▪ Submittal: Sent Electronically</li> <li>▪ O&amp;M Manual: Sent Electronically</li> </ul> <p><i>Please notify us if an alternate quantity is required so that we can modify our proposal accordingly.</i></p>	
14.	<b>FCA Factory, Campbell, CA with Full Freight Allowed to Jobsite, Costa Mesa, CA</b>	Included
	<b>BUDGETARY PRICE [ITEMS 1-14]</b>	<b>\$173,000</b>

**B. RESERVOIR 1 - SCOPE OF WORK BY OTHERS**

1. Equipment unloading and placement.
2. Enclosure or Shelter for Booster pumps and Flowmeters
3. All civil works and concrete pad for equipment.
4. Any underground or structural work.
5. Design and supply of anchor bolts and seismic restraints.
6. All communication wiring to Booster Pump(s), and Booster Pump Variable Frequency Drive(s).
7. Interconnecting communication wiring between Booster Pump(s) and Booster Pump Variable Frequency Drive(s).
8. **All electrical wiring from MCC/supply to Control Panel (120VAC, 1Φ, 60Hz) and Variable Frequency Drives (240VAC, 1Φ, 60Hz).**
9. Conduit for communication and electrical wiring.
10. Valves, fittings, appurtenances not specifically listed under Scope of Supply by Process Solutions, Inc.
11. All hose, tubing and pipe supports, strut, and clamps.
12. Freeze protection for hose, tubing and piping, if required.
13. Hatch penetrations or modifications.
14. All taxes, fees, lien waivers, bonds and licenses.
15. Permitting or regulatory approval.
16. Any items not explicitly listed under Scope of Supply by Process Solutions, Inc.

### C. RESERVOIR 2 - SCOPE OF WORK BY PROCESS SOLUTIONS, INC.

The following equipment and services are included in our scope of work. All equipment will be manufactured in accordance with our standard equipment. Please see attached equipment general arrangement drawing for illustration and reference.

<b>No</b>	<b><u>Item Description</u></b>	<b><u>Qty.</u></b>
1.	<b>Monoclor™ Control Panel</b> , including: <ul style="list-style-type: none"> <li>▪ NEMA 4X Enclosure – 304 Stainless Steel Construction</li> <li>▪ Allen-Bradley MicroLogix 1400 Programmable Logic Controller (PLC)</li> <li>▪ Ethernet Communication</li> <li>▪ Remote Monitoring Telemetry</li> <li>▪ 6" Color Touchscreen Human-Machine Interface (HMI)</li> <li>▪ 24 VDC Power Supply</li> <li>▪ Emergency Stop Pushbutton</li> <li>▪ Panel-Mounted Disconnect Switch</li> </ul>	1
2.	<b>Hypochlorite Storage Tank</b> , including: <ul style="list-style-type: none"> <li>▪ HDLPE Construction</li> <li>▪ Double-Wall Containment</li> <li>▪ 500 Gallon Capacity</li> <li>▪ Ultrasonic Level Control</li> <li>▪ Top Manway</li> <li>▪ Dimensions: 4'-11"D x 5'-11"H</li> </ul>	1
3.	<b>Ammonia Storage Tank</b> , including: <ul style="list-style-type: none"> <li>▪ HDLPE Construction</li> <li>▪ Ultratainer with Saf-Tainer Containment</li> <li>▪ 220 Gallon Capacity with 485 Gallon Containment</li> <li>▪ Ultrasonic Level Control</li> <li>▪ Top Manway</li> <li>▪ Dimensions: 3'-10"D x 3'-10"H (Tank) 66"W x 66"L x 30"H (Containment)</li> </ul>	1
4.	<b>Hypochlorite Dosing Skid</b> , including: <ul style="list-style-type: none"> <li>▪ Metering Pump, 10 GPH @ 145 PSI with TEFC Inverter-Duty Motor (Qty. 2)</li> <li>▪ NEMA 4X Variable Frequency Drive (Qty. 2)</li> <li>▪ Calibration Column (Qty. 1)</li> <li>▪ Pressure Relief Valve (Qty. 2)</li> <li>▪ Backpressure Valve (Qty. 2)</li> <li>▪ Pulsation Dampener (Qty. 2)</li> <li>▪ Wye Strainer (Qty. 1)</li> <li>▪ Pressure Gauge (Qty. 2)</li> <li>▪ Flow Verification Sensor (Qty. 2)</li> </ul> <p><b>Note: Dosing Pumps to Be Mounted on a Pre-Plumbed PVC Skid.</b></p>	1

<u>No</u>	<u>Item Description</u>	<u>Qty.</u>
5.	<p><b>Ammonia Dosing Skid</b>, including:</p> <ul style="list-style-type: none"> <li>▪ Metering Pump, 2.4 GPH @ 87 PSI with TEFC Inverter-Duty Motor (Qty. 2)</li> <li>▪ Calibration Column (Qty. 1)</li> <li>▪ Pressure Relief Valve (Qty. 2)</li> <li>▪ Backpressure Valve (Qty. 2)</li> <li>▪ Pulsation Dampener (Qty. 2)</li> <li>▪ Wye Strainer (Qty. 1)</li> <li>▪ Pressure Gauge (Qty. 2)</li> <li>▪ Flow Verification Sensor (Qty. 2)</li> </ul> <p><b>Note: Dosing Pumps to Be Mounted on a Pre-Plumbed PVC Skid.</b></p>	1
6.	<p><b>Tank Shark® Mixing System</b>, including:</p> <ul style="list-style-type: none"> <li>▪ 100 gpm Maximum Volumetric Flow Rate</li> <li>▪ Dual-Nozzle Motive Water Mixing Nozzle Assembly</li> <li>▪ Chlorine Injection Nozzle Assembly</li> <li>▪ Sampling Assembly</li> <li>▪ Bottom Feed Configuration</li> <li>▪ Standard Base</li> <li>▪ Reinforced PVC Water &amp; Hypochlorite Hoses from Tank Shark® to Tank/Reservoir Hatch</li> <li>▪ Polyethylene Sample Tubing from Tank Shark® to Tank/Reservoir Hatch</li> <li>▪ Stainless Steel Tethering Assembly</li> <li>▪ Electropolished 304 Stainless Steel Base and Mast Assembly</li> </ul> <p><b>Note: Two Mixers Include Chemical Dosing Lines and Nozzles.</b></p>	4
7.	<p><b>Stainless Steel Vertical Turbine Booster Pump</b>, including:</p> <ul style="list-style-type: none"> <li>▪ 7.5 HP EPAAct-Efficiency, TEFC Motor</li> <li>▪ 25 HP NEMA 1 Variable Frequency Drive</li> <li>▪ NEMA 3R VFD Enclosure</li> </ul>	4
8.	<p><b>Flow Meter</b></p> <ul style="list-style-type: none"> <li>▪ Magnetic Flow Meter for Water Line</li> </ul>	4
9.	<p><b>Chlorine Analyzer</b></p> <ul style="list-style-type: none"> <li>▪ Magnetic Flow Meter for Water Line</li> </ul>	1
10.	<p><b>Analyzer Sample Pump</b></p> <ul style="list-style-type: none"> <li>▪ Mag Drive, 1 GPM</li> </ul>	1



<u>No</u>	<u>Item Description</u>	<u>Qty.</u>
11.	<b>Installation of Monoclor™ System</b> , including <ul style="list-style-type: none"> <li>▪ Installation of Tank Shark® Systems</li> <li>▪ Tank Penetrations</li> <li>▪ Plumbing between equipment</li> <li>▪ Piping as shown on drawings</li> <li>▪ Installation materials including interconnecting piping, tubing, valves, and strut</li> </ul>	Included
12.	<b>Manufacturer’s Services for System Start-Up and Operator Training (3 Days at the Jobsite)</b>	Included
13.	<b>Design Submittal and Operation &amp; Maintenance Manual as Follows</b> <ul style="list-style-type: none"> <li>▪ Submittal: Sent Electronically</li> <li>▪ O&amp;M Manual: Sent Electronically</li> </ul> <i>Please notify us if an alternate quantity is required so that we can modify our proposal accordingly.</i>	Included
14.	<b>FCA Factory, Campbell, CA with Full Freight Allowed to Jobsite, Costa Mesa, CA</b>	Included
	<b>BUDGETARY PRICE [ITEMS 1-13]</b>	<b>\$198,000</b>
	<b>TOTAL PROJECT PRICE [RESERVOIR 1 &amp; 2]</b>	<b>\$371,000</b>

**D. RESERVOIR 2 - SCOPE OF WORK BY OTHERS**

17. Equipment unloading and placement.
18. Enclosure or Shelter for Booster pumps and Flowmeters
19. All civil works and concrete pad for equipment.
20. Any underground or structural work.
21. Design and supply of anchor bolts and seismic restraints.
22. All communication wiring to Booster Pump(s), and Booster Pump Variable Frequency Drive(s).
23. Interconnecting communication wiring between Booster Pump(s) and Booster Pump Variable Frequency Drive(s).
24. **All electrical wiring from MCC/supply to Control Panel (120VAC, 1Φ, 60Hz) and Variable Frequency Drives (240VAC, 1Φ, 60Hz).**
25. Conduit for communication and electrical wiring.
26. Valves, fittings, appurtenances not specifically listed under Scope of Supply by Process Solutions, Inc.
27. All hose, tubing and pipe supports, strut, and clamps.
28. Freeze protection for hose, tubing and piping, if required.
29. Hatch penetrations or modifications.
30. All taxes, fees, lien waivers, bonds and licenses.
31. Permitting or regulatory approval.
32. Any items not explicitly listed under Scope of Supply by Process Solutions, Inc.

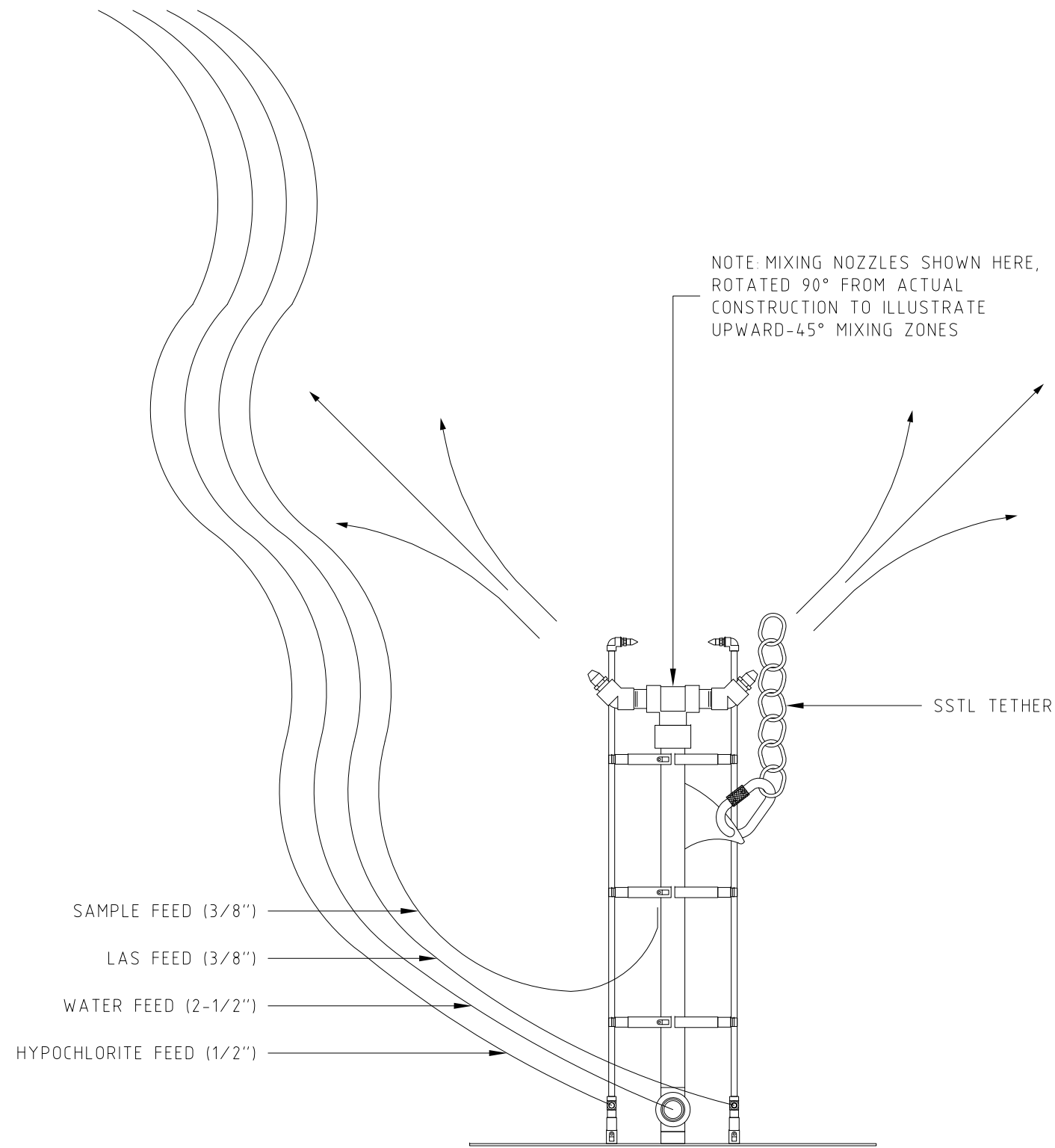

**DETAIL**

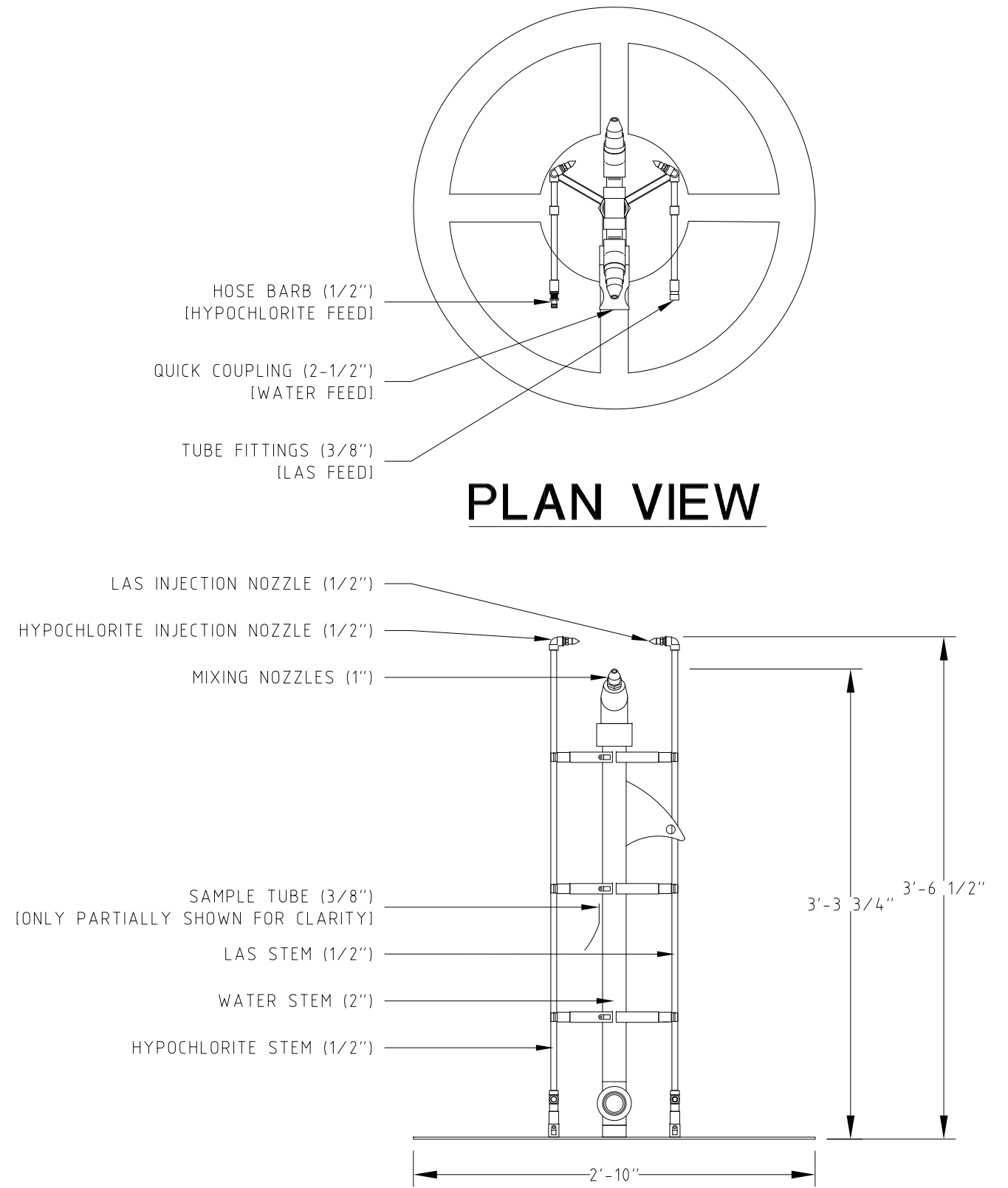

**PLAN VIEW**

**ELEVATION VIEW**

REV. △	DATE	BY	DESCRIPTION	REV. △	DATE	BY	DESCRIPTION
△ A	01/24/17	MK	CREATED	△			
△				△			
△				△			
△				△			

This drawing represents an investment by PROCESS SOLUTIONS, INC of substantial sums, including our engineering skills and experience. It is, therefore, loaned without consideration other than the agreement and condition that it is not to be used in whole or in part to assist in making or to furnish any information to others for the making of drawings, print apparatus, or parts thereof. The acceptance of this drawing will be construed as an acceptance of the forgoing conditions and as an admission of the exclusive ownership in and to the drawings of PROCESS SOLUTIONS, INC.

**PSI On-Site Disinfection**  
A UGSI SOLUTIONS COMPANY

PROJECT: PROCESS SOLUTIONS, INC. STANDARD DRAWING

SUBJECT: TANK SHARK TS-100, DUAL NOZZLE, CIRCULAR BASE GENERAL ARRANGEMENT

DWG #: 000000-TSDC10-AB SHEET 1 OF 1 REV. A

DRAWN BY: M. KUSHMAN DATE: 01/24/2017

CHECKED BY: DATE:

SCALE: 2"=1'-0" SIZE: D

[This page is intentionally left blank.]

## **A-2. PAX Mixer – Drawings and Budgetary Estimates**

[This page is intentionally left blank.]

# PAX Water Mixer Family – for All Types of Tanks

## PWM100 / PWM150

Compact, lightweight jet mixer. Utilizes PAX's patented vortex nozzle design for powerful mixing in small to mid-size tanks.

### TANK SIZE:

Up to 375,000 gal (PWM100)  
Up to 750,000 gal (PWM150)

### TECHNICAL DATA:

Power Supply: 120 VAC  
Power Draw: 670 watts  
Height: 30" (PWM100)  
34" (PWM150)  
Weight: 40 lbs (PWM100)  
42 lbs (PWM150)

### FEATURES:

- Self-install design
- Points upward, even on sloped floor
- Completely NSF-61 certified

### OPTIONS:

- Chemical feed attachment
- SCADA-compatible

## PWM200 / PWM400 / PWM500 / PWM600

Powerful tripod-mounted mixer using PAX's patented Lily impeller to create power and energy efficiency

### TANK SIZE:

Up to 0.75 MG (PWM200)  
Up to 9 MG (PWM400)  
Up to 15 MG (PWM500)  
Up to 25 MG (PWM600)

### TECHNICAL DATA:

Power supply: 120/240 VAC  
Power draw: 575 watts (PWM200)  
345 watts (PWM400)  
825 watts (PWM500)  
2,130 watts (PWM600)  
Height: 38" (PWM200)  
49" (PWM400, PWM500, PWM600)  
Weight: 47 lbs (PWM200)  
53 lbs (PWM400)  
59 lbs (PWM500)  
71 lbs (PWM600)

### FEATURES:

- Fixed or free-standing installation
- SCADA-compatible
- Completely NSF-61 certified

### OPTIONS:

- Chemical feed attachment
- Solar powered
- Self-install design



# and Process Conditions

## PWM400-VAM / PWM500-VAM / PWM600-VAM

Powerful low-angle mixer using PAX's patented Lily impeller to create thorough circulation in large, shallow reservoirs

### TANK SIZE:

Up to 8 MG (PWM400-VAM)  
Up to 14 MG (PWM500-VAM)  
Up to 20 MG (PWM600-VAM)

### TECHNICAL DATA:

Power supply: 120/240 VAC  
Power draw: 345 watts (PWM400-VAM)  
825 watts (PWM500-VAM)  
2,130 watts (PWM600-VAM)  
Height: 31"  
Weight: 73 lbs (PWM400-VAM)  
80 lbs (PWM500-VAM)  
90 lbs (PWM600-VAM)

### FEATURES:

- Free-standing installation
- Self-installable
- SCADA-compatible
- Completely NSF-61 certified

### OPTIONS:

- Chemical feed attachment
- Solar powered



No Mixer

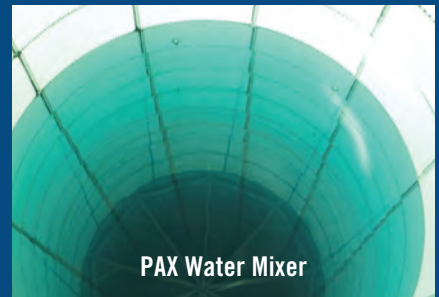

PAX Water Mixer

>> The PAX Water Mixer works, plain and simple. I'm never going to worry about ice again."

—Frank Kearney Sr., Superintendent, Old Town Water District, Maine



MESA WATER.dwg  
4/20/2016

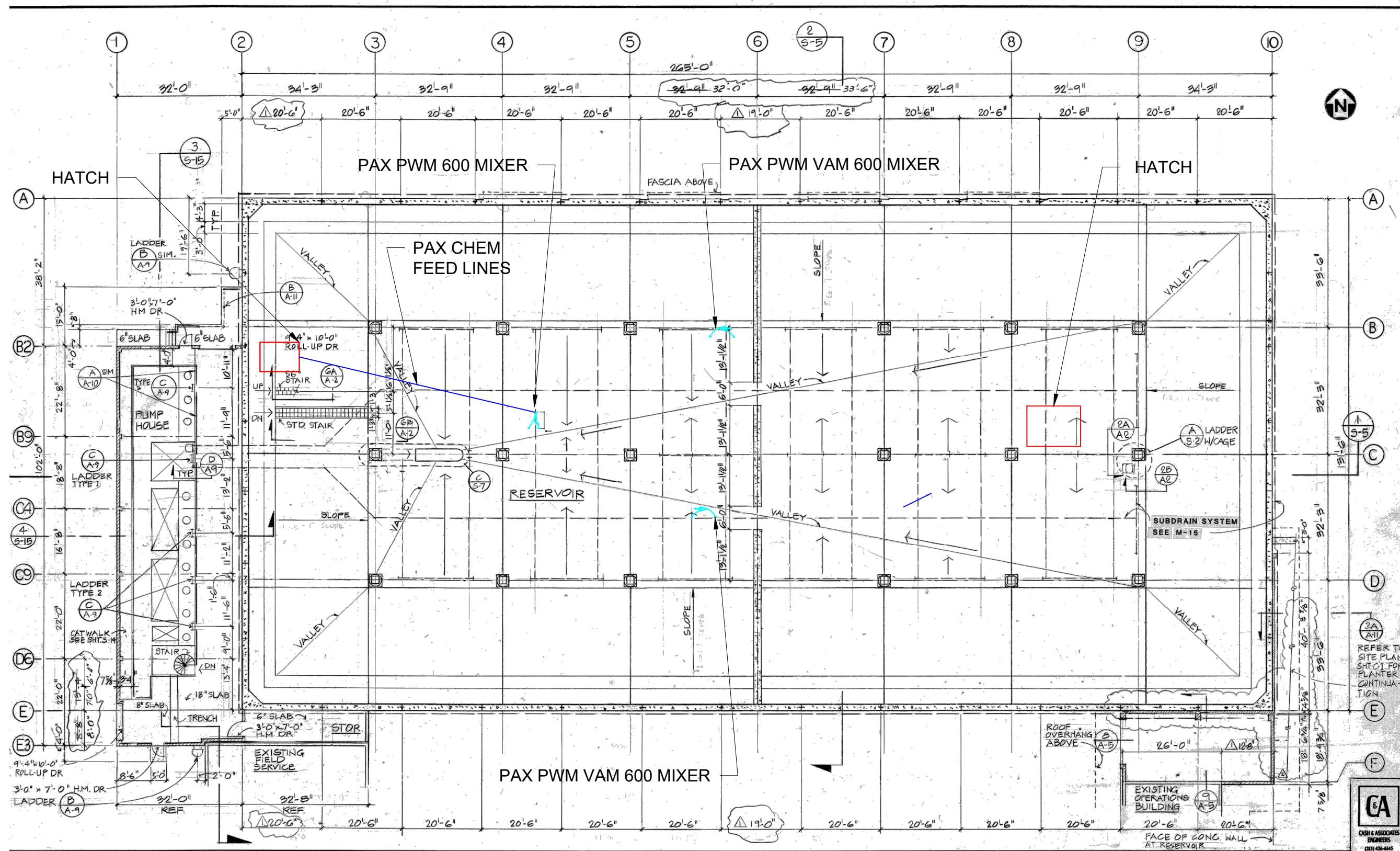

STAMP

PROJECT NAME/ADDRESS  
 PROJECTNAME  
 PROJECTADDRESS1  
 PROJECTADDRESS2  
 PROJECTADDRESS3

PROJECT TITLE  
 PROJECTNAME

No.	Revision/Issue	Date

COMPANY NAME/ADDRESS  
**PAX**  
 WATER TECHNOLOGIES<sup>®</sup>

SHEET NAME  
 RESERVOIR 1 PAX PWM 600  
 TRIPOD AND PAX PWM 600  
 VAM LOCATIONS  
 C101

Project	PROJECTNAME	Sheet
Date	DATE	C101
Scale	SCALE	

FLOOR PLAN

Street work plans reviewed and agreed to pursuant to Public Utilities Code Section 10103 City of Costa Mesa  
 by \_\_\_\_\_ date \_\_\_\_\_

PLANS PREPARED UNDER THE SUPERVISION OF  
*Robert H. Boone*  
 R.O.E.  
 APPROVED BY  
*[Signature]*  
 MESA CONSOLIDATED WATER DISTRICT

**Mesa Consolidated Water District**  
 YOUR INDEPENDENT WATER AGENCY  
 1965 Piacentia Avenue - Costa Mesa, Ca 92627 - 714 631-1291

DATE	BY	REVISION DESCRIPTION	APP'D	DATE
3-21-88	FHH	Δ CLOSE EAST OPENING AT PORTE COCHERE	MS	RK FHH
1-7-85	VL	Δ REVISED DIMENSIONS	des.	dwn
			EHE	5/20/87
			chk	date

10 MILLION GALLON RESERVOIR  
**FLOOR PLAN**  
 PLAN SCALE 3/32" = 1'-0"

**CA**  
 C&E ASSOCIATES  
 ENGINEERS  
 (313) 436-4045  
 Long Beach, CA  
 2650.01'



[This page is intentionally left blank.]

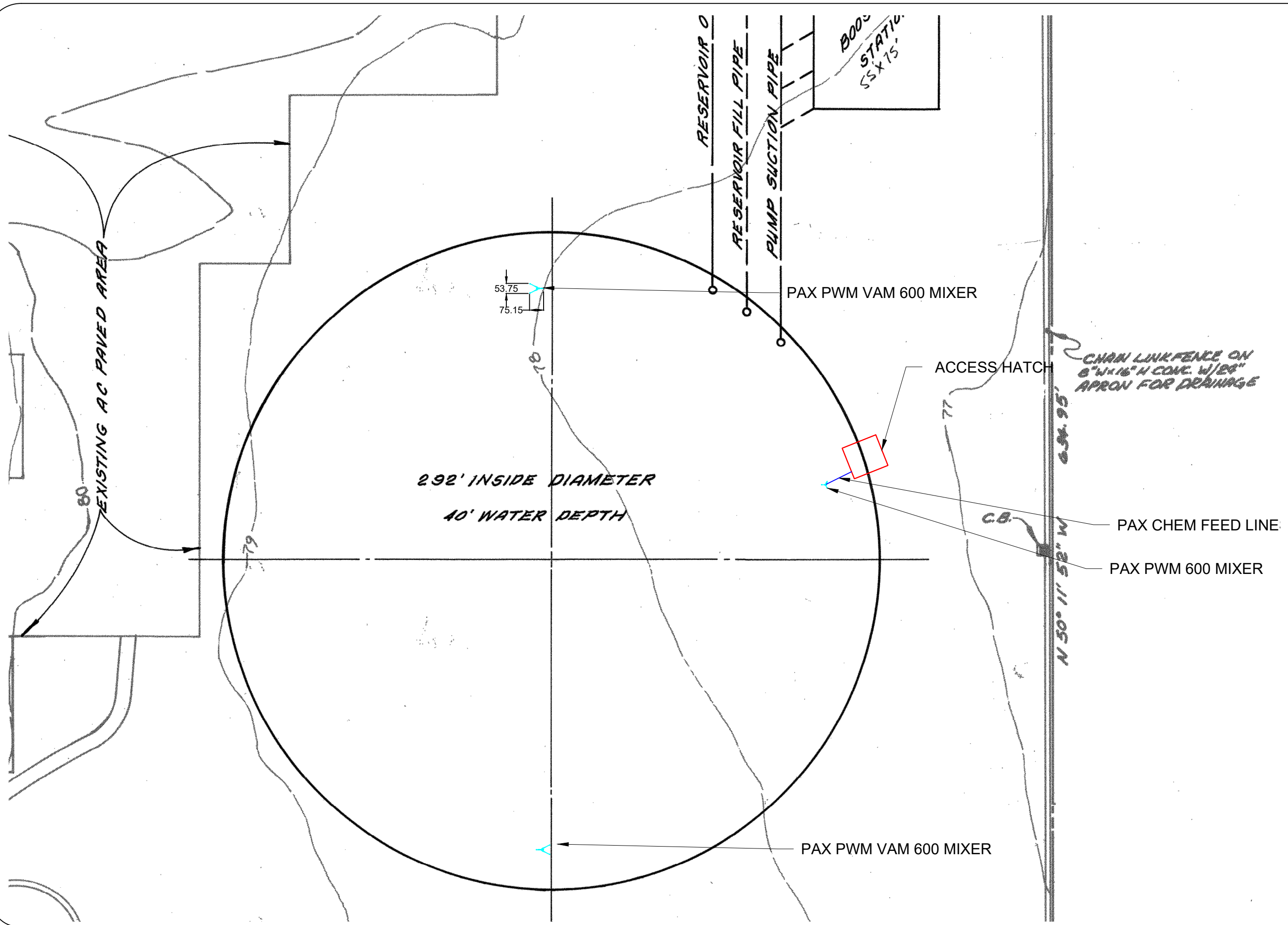

STAMP

PROJECT NAME/ADDRESS  
PROJECTNAME  
PROJECTADDRESS1  
PROJECTADDRESS2  
PROJECTADDRESS3

PROJECT TITLE  
PROJECTNAME

No.	Revision/Issue	Date

COMPANY NAME/ADDRESS  
**PAX**  
WATER TECHNOLOGIES<sup>®</sup>

SHEET NAME  
RESERVOIR 2  
PAX PWM 600 TRIPOD AND  
PAX PWM 600 VAM  
LOCATIONS  
C102

Project PROJECTNAME	Sheet C102
Date DATE	
Scale SCALE	

[This page is intentionally left blank.]

## RCS Sales Proposal

<b>Project:</b>	Mesa Consolidated Water District
<b>Tank Details:</b>	(2) 5MG Tanks separated by baffle (10MG Reservoir)
<b>Disinfectant:</b>	Chloramines
<b>RCS Components:</b>	PAX Water Mixer, Chemical Feed System, Water Quality Station, Smart Controller
<b>Proposal Date:</b>	January 18 <sup>th</sup> , 2017
<b>Proposal Valid:</b>	3 months from offer date (90 days)

---

PAX Water Technologies is pleased to offer a Residual Control System (RCS) proposal for the 10MG Reservoir 1 located for Mesa Consolidated Water District, CA. The baffled tank will be operated as 2 separate tanks, 5MG per side.

Per your request, I have detailed pricing for a complete RCS, including the PAX Water Mixer, Chemical Feed System, Water Quality Station and Smart Controller. Below you will find a brief description of RCS, our scope and pricing tables, standard terms and conditions, followed by datasheets for each of the RCS components.

### **Reservoir Control System (RCS)**

The PAX Residual Control System (RCS) is an intelligent disinfectant boosting system that gives operators the ability to set and maintain residual levels in water storage tanks and key locations in the distribution system. By combining advanced water quality sensors with powerful tank mixing and an automated chemical feed system, the PAX RCS enables operators to eliminate manual boosting and quickly counteract adverse water quality changes.

### **PAX Water Mixer**

The PAX Water Mixer is a powerful active mixer that improves water quality in storage tanks. The mixer's patented Lily impeller creates a powerful vortex flow pattern to completely blend disinfectant chemicals into the entire volume of water, enabling maximum water quality stability and sample reliability. The mixer installs easily without service disruptions or tank modifications, and mixes on-demand to rapidly eliminate stratification, uniformly distribute disinfectants and prevent conditions favorable to nitrification.

### **Basic SCADA**

The RCS comes with basic SCADA capability with functionality for 8 standard outputs (i.e. total chlorine, temperature, pH, etc.). The mixer also comes with standard SCADA functions: input (dry contact required), on/off control, dry contact outputs running, and fault, which is independent of the RCS SCADA function.

### **Remote Monitoring System (RMS)**

The RMS is an augmented version of the SCADA system, which can be programmed to send alarms directly to an operator's cell phone using text messages. It can also transmit data related to water quality and RCS operation to a secure internet data hosting platform accessible by the web.



**Start-up & Service**

Equipment commissioning and start-up will be provided by PAX or their representatives. Because this is a complex piece of equipment, calibration and maintenance training will be provided by PAX and is outlined in the following scope and pricing tables.

If you have any questions, please contact me by email or cell. The PAX team appreciates the opportunity to work with you and the Mesa Consolidated Water District to implement a solution – we look forward your feedback on this proposal.

Kind regards,

Teresa Corrington  
Western Regional Manager  
PAX Water Technologies  
Cell: 253.398.4937  
Email: [tcorrington@paxwater.com](mailto:tcorrington@paxwater.com)

<b>EQUIPMENT SUPPLIED BY MUNICIPALITY / CONTRACTOR</b>	
<b>Item</b>	<b>Description</b>
<b>Chlorine Supply</b>	12.5% chlorine solution
<b>Ammonia Supply</b>	19% ammonia solution
<b>Power Supply</b>	115VAC to sub panel w/ breaker and safety disconnect switch where RCS control will be located
<b>Conduit</b>	<p>Conduit for Chemical Feed and sample lines to tank penetrations; PAX will help with specifications</p> <p>Conduit for line power from the distribution panel to sub panels for Chemical Feed and PAX Water Mixer controls; PAX will help with specifications</p> <p>Conduit from the Smart Controller to the junction box just prior to entering the wet area of the tank; PAX will help with specifications</p>
<b>Tank Penetrations</b>	Municipality/Contractor will provide fittings for tank penetration at time of installation; PAX will provide recommendations

<b>EQUIPMENT SUPPLIED (PER TANK) BY PAX WATER TECHNOLOGIES</b>		
<b>Item</b>	<b>Quantity</b>	<b>Description</b>
<b>Water Quality Station (WQS)</b>	1	Advanced sensors that continuously monitor water quality and sends data to the Smart Controller, including temperature, pH and chlorine level
<b>Smart Controller</b>	1	Automated control system that analyzes data from WQS, maintains operator-set residual level and sends data to SCADA and alerts to operator
<b>Chem Feed Skid: Chlorine</b>	1	Chemical feed skid that automatically doses chlorine based on commands from Smart Controller (duty/standby)
<b>Chem Feed Skid: Ammonia</b>	1	Chemical feed skid that automatically doses ammonia based on commands from Smart Controller (duty/standby)
<b>PAX Water Mixer: PWM600/605</b>	2	Tripod-mounted active mixer that thoroughly blends chemicals being dosed; comes with control panel
<b>Sample Return Kit</b>	1	30-gallon tank, level controls and recovery pump
<b>Tank Penetrations (TBD)</b>	TBD	PAX will provide fittings for tank penetration at time of installation (usually a modified cathodic protection plate)

<b>RCS PRICING (ESSENTIAL COMPONENTS)</b>				
<b>Item</b>		<b>Quantity</b>	<b>Price Per Unit</b>	<b>Total Price</b>
PAX Water Mixer (PWS600/605)		2	\$42,800	\$85,600
RCS	Water Quality Station	2	\$53,000	\$106,000
	Smart Controller			
	Chemical Feed System (Chlorine & Ammonia)			
PAX Training Package <sup>1</sup>		2	\$6,800	\$13,600
Mixer Self-Install Kit		2	\$900	\$1,800
Sample Return Kit		2	\$1,800	\$3,600
Subtotal				\$210,600
Shipping & Handling				\$2,400
<b>Total Equipment Costs (not including installation and tax<sup>2</sup>)</b>				\$233,000

Note: If tank is not drained at the time of installation, a diver may be required to install the mixer. PAX can recommend a diving company, if requested.

1. PAX Training Package:
  - a. PAX Water will provide one technician for 1-2 days of initial startup of equipment, calibration, initial tuning of software and onsite training.
  - b. The PAX RMS is an augmented version of the SCADA system, which can be programmed to send alarms directly to an operator's cell phone via text messages, take commands via secure web portal through operator's smart phone for complete control and receive PAX Service Support. RMS functionality is included for the first three months with the installation beginning at startup.
  - c. PAX Remote Monitoring is included for three months to fine tune RCS components and provide technical support to your municipality as you learn RCS functionality.
  - d. PAX will provide two additional days of operator training at typically at 4-8 weeks after start-up, with topic of instruction based on RCS operation and personnel needs. Beyond the standard training package, PAX offers advanced operator training on a fee-per-day basis.
2. If municipality is tax exempt, please provide proper documentation.

PAX recommends shelters for housing the RCS control center and chemical feed systems. PAX recommends separate enclosures for chlorine and ammonia. PAX can provide basic guidelines for dimensions and requirements. The utility may choose FRP shelters, a shelter constructed on-site or even portable-type plastic cabinets such as those used at trial sites. PAX does not provide site engineering services.

## *Mesa WD Reservoir 1: Project Estimate*

Complete RCS system Estimate (equipment, start-up, freight included):

Includes all aforementioned RCS equipment components in addition to:

- 120 Gal Dual Wall Polyethylene Ammonia Storage tank
- 40 Gal Ammonia Scrubber (water bath style)
- 550 Gal Dual Wall Polyethylene Sodium Hypochlorite Storage tank
- Sample draw system

Equipment Cost: **\$247,000**

Installation Cost (plumbing, electrical, diver):

- RCS equipment install (includes installation of above-ground sample lines and all electrical for the chemical feed skid, smart controller, water quality station, sample pump and sample return system): \$20,000
- Mixer Install (done by diver): \$2,400

Service Contract (includes annual service on RCS system and Mixer extraction): \$6,000

Total Budgetary Estimate for Equipment and Install: **\$275,400**



## RCS Sales Proposal

<b>Project:</b>	Mesa Consolidated Water District
<b>Tank Details:</b>	20MG Reservoir 2
<b>Disinfectant:</b>	Chloramines
<b>RCS Components:</b>	PAX Water Mixer, Chemical Feed System, Water Quality Station, Smart Controller
<b>Proposal Date:</b>	January 18 <sup>th</sup> , 2017
<b>Proposal Valid:</b>	3 months from offer date (90 days)

---

PAX Water Technologies is pleased to offer a Residual Control System (RCS) proposal for the 10MG Reservoir 1 located for Mesa Consolidated Water District, CA. Per your request, I have detailed pricing for a complete RCS, including the PAX Water Mixer, Chemical Feed System, Water Quality Station and Smart Controller. Below you will find a brief description of RCS, our scope and pricing tables, standard terms and conditions, followed by datasheets for each of the RCS components.

### **Reservoir Control System (RCS)**

The PAX Residual Control System (RCS) is an intelligent disinfectant boosting system that gives operators the ability to set and maintain residual levels in water storage tanks and key locations in the distribution system. By combining advanced water quality sensors with powerful tank mixing and an automated chemical feed system, the PAX RCS enables operators to eliminate manual boosting and quickly counteract adverse water quality changes.

### **PAX Water Mixer**

The PAX Water Mixer is a powerful active mixer that improves water quality in storage tanks. The mixer's patented Lily impeller creates a powerful vortex flow pattern to completely blend disinfectant chemicals into the entire volume of water, enabling maximum water quality stability and sample reliability. The mixer installs easily without service disruptions or tank modifications, and mixes on-demand to rapidly eliminate stratification, uniformly distribute disinfectants and prevent conditions favorable to nitrification.

### **Basic SCADA**

The RCS comes with basic SCADA capability with functionality for 8 standard outputs (i.e. total chlorine, temperature, pH, etc.). The mixer also comes with standard SCADA functions: input (dry contact required), on/off control, dry contact outputs running, and fault, which is independent of the RCS SCADA function.

### **Remote Monitoring System (RMS)**

The RMS is an augmented version of the SCADA system, which can be programmed to send alarms directly to an operator's cell phone using text messages. It can also transmit data related to water quality and RCS operation to a secure internet data hosting platform accessible by the web.

**Start-up & Service**

Equipment commissioning and start-up will be provided by PAX or their representatives. Because this is a complex piece of equipment, calibration and maintenance training will be provided by PAX and is outlined in the following scope and pricing tables.

If you have any questions, please contact me by email or cell. The PAX team appreciates the opportunity to work with you and the Mesa Consolidated Water District to implement a solution – we look forward your feedback on this proposal.

Kind regards,

Teresa Corrington  
Western Regional Manager  
PAX Water Technologies  
Cell: 253.398.4937  
Email: [tcorrington@paxwater.com](mailto:tcorrington@paxwater.com)

<b>EQUIPMENT SUPPLIED BY MUNICIPALITY / CONTRACTOR</b>	
<b>Item</b>	<b>Description</b>
<b>Chlorine Supply</b>	12.5% chlorine solution
<b>Ammonia Supply</b>	19% ammonia solution
<b>Power Supply</b>	115VAC to sub panel w/ breaker and safety disconnect switch where RCS control will be located
<b>Conduit</b>	<p>Conduit for Chemical Feed and sample lines to tank penetrations; PAX will help with specifications</p> <p>Conduit for line power from the distribution panel to sub panels for Chemical Feed and PAX Water Mixer controls; PAX will help with specifications</p> <p>Conduit from the Smart Controller to the junction box just prior to entering the wet area of the tank; PAX will help with specifications</p>
<b>Tank Penetrations</b>	Municipality/Contractor will provide fittings for tank penetration at time of installation; PAX will provide recommendations

<b>EQUIPMENT SUPPLIED (PER TANK) BY PAX WATER TECHNOLOGIES</b>		
<b>Item</b>	<b>Quantity</b>	<b>Description</b>
<b>Water Quality Station (WQS)</b>	1	Advanced sensors that continuously monitor water quality and sends data to the Smart Controller, including temperature, pH and chlorine level
<b>Smart Controller</b>	1	Automated control system that analyzes data from WQS, maintains operator-set residual level and sends data to SCADA and alerts to operator
<b>Chem Feed Skid: Chlorine</b>	1	Chemical feed skid that automatically doses chlorine based on commands from Smart Controller (duty/standby)
<b>Chem Feed Skid: Ammonia</b>	1	Chemical feed skid that automatically doses ammonia based on commands from Smart Controller (duty/standby)
<b>PAX Water Mixer: PWM600/605</b>	1	Tripod-mounted active mixer that thoroughly blends chemicals being dosed; comes with control panel
<b>PAX Water Mixer: PWM 600-VAM</b>	2	Horizontal-mounted active mixer that thoroughly blends chemicals being dosed; comes with control panel.
<b>Sample Return Kit</b>	1	30-gallon tank, level controls and recovery pump
<b>Tank Penetrations (TBD)</b>	TBD	PAX will provide fittings for tank penetration at time of installation (usually a modified cathodic protection plate)

<b>RCS PRICING (ESSENTIAL COMPONENTS)</b>				
<b>Item</b>		<b>Quantity</b>	<b>Price Per Unit</b>	<b>Total Price</b>
PAX Water Mixer (PWS600/605)		1	\$42,800	\$42,800
PAX Water Mixer (PWM 600-VAM)		2	47,800	95,600
RCS	Water Quality Station	1	\$63,000	\$63,000
	Smart Controller			
	Chemical Feed System (Chlorine & Ammonia)			
PAX Training Package <sup>1</sup>		1	\$6,800	\$6,800
Mixer Self-Install Kit		1	\$900	\$900
Sample Return Kit		1	\$1,800	\$1,800
Subtotal				\$210,900
Shipping & Handling				\$1,800
<b>Total Equipment Costs (not including installation and tax<sup>2</sup>)</b>				\$212,700

Note: If tank is not drained at the time of installation, a diver may be required to install the mixer. PAX can recommend a diving company, if requested.

1. PAX Training Package:
  - a. PAX Water will provide one technician for 1-2 days of initial startup of equipment, calibration, initial tuning of software and onsite training.
  - b. The PAX RMS is an augmented version of the SCADA system, which can be programmed to send alarms directly to an operator’s cell phone via text messages, take commands via secure web portal through operator’s smart phone for complete control and receive PAX Service Support. RMS functionality is included for the first three months with the installation beginning at startup.
  - c. PAX Remote Monitoring is included for three months to fine tune RCS components and provide technical support to your municipality as you learn RCS functionality.
  - d. PAX will provide two additional days of operator training at typically at 4-8 weeks after start-up, with topic of instruction based on RCS operation and personnel needs. Beyond the standard training package, PAX offers advanced operator training on a fee-per-day basis.
2. If municipality is tax exempt, please provide proper documentation.

PAX recommends shelters for housing the RCS control center and chemical feed systems. PAX recommends separate enclosures for chlorine and ammonia. PAX can provide basic guidelines for dimensions and requirements. The utility may choose FRP shelters, a shelter constructed on-site or even portable-type plastic cabinets such as those used at trial sites. PAX does not provide site engineering services.

## *Mesa WD Reservoir 2: Project Estimate*

Complete RCS system Estimate (equipment, start-up, freight included):

Includes all aforementioned RCS equipment components in addition to:

- 120 Gal Dual Wall Polyethylene Ammonia Storage tank
- 40 Gal Ammonia Scrubber (water bath style)
- 550 Gal Dual Wall Polyethylene Sodium Hypochlorite Storage tank
- Sample draw system

Equipment Cost: **\$226,000**

Installation Cost (plumbing, electrical, diver):

- RCS equipment install (includes installation of below-grade sample lines and all electrical for the chemical feed skid, smart controller, water quality station, sample pump and sample return system): \$20,000
- Mixer Install (done by diver): \$3,600

Service Contract (includes annual service on RCS system and Mixer extraction): \$7,400

Total Budgetary Estimate for Equipment and Install: **\$257,000**

## **A-3. Vortex Mixer – Drawings and Budgetary Estimates**

[This page is intentionally left blank.]



<b>SUPERIOR WATER TECHNOLOGIES</b>
<b>VORTEX RESERVOIR MIXER</b>
<b>RESERVOIR MANAGEMENT</b>
<b>CHEMICAL FEED</b>
<b>RESIDUAL MAINTENANCE</b>

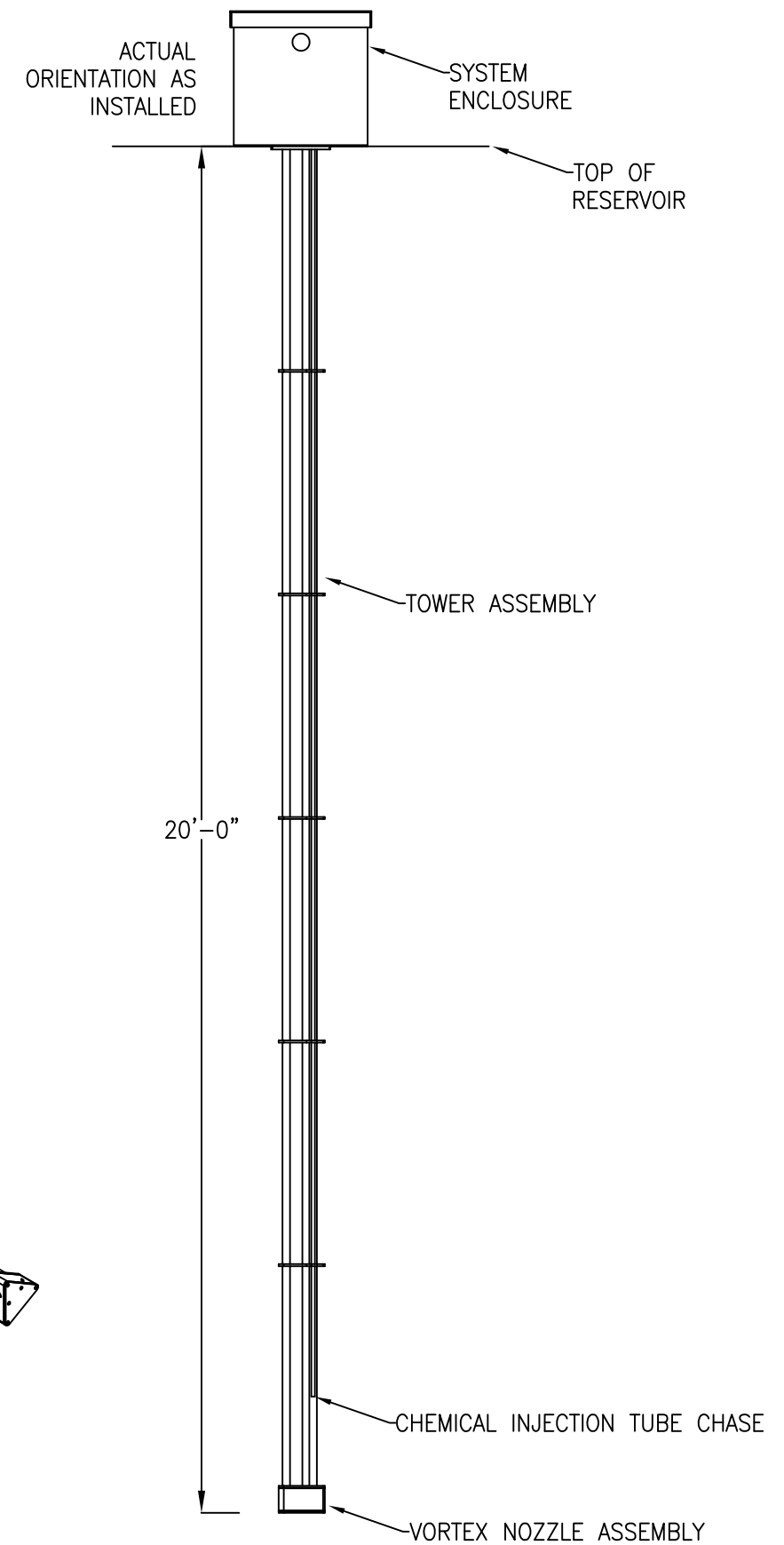
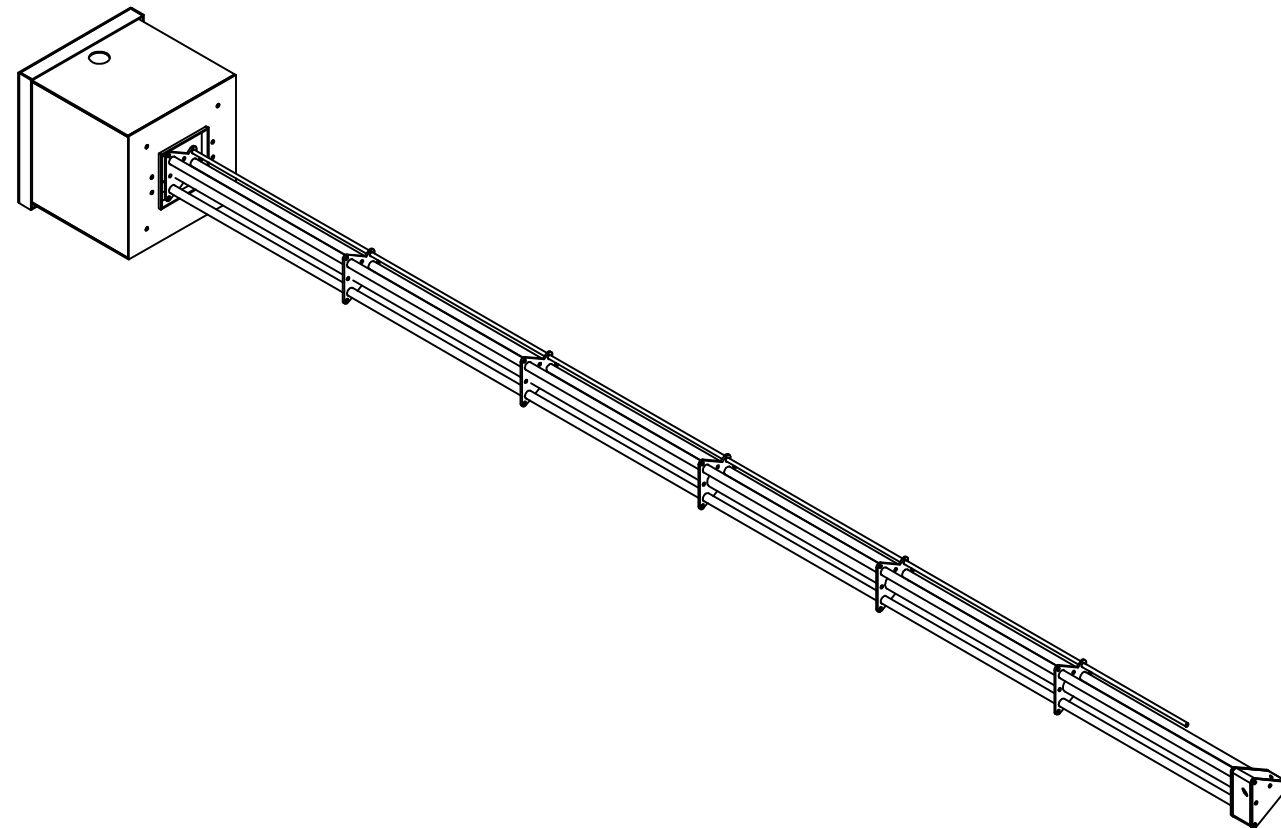

SUPERIOR WATER TECHNOLOGIES IS NOT BE RESPONSIBLE FOR ANY LAYOUT OR PLACEMENT OF ANY/ALL EQUIPMENT WHETHER SHOWN IN THESE DRAWINGS OR OTHERWISE. SUPERIOR WATER IS ALSO NOT RESPONSIBLE FOR LOCAL OR STATE CODES IN REGARDS TO ANY DESIGN WHETHER SAFETY RELATED OR OTHERWISE. THESE DRAWINGS ARE SUGGESTIONS ONLY AND SHALL BE TREATED AS SUCH. FAILURE TO FOLLOW APPROPRIATE CODES AND REGULATIONS IS NOT THE RESPONSIBILITY OF SUPERIOR WATER TECHNOLOGIES.

REV	DESCRIPTION	DATE	BY

\_\_\_PRELIMINARY \_\_\_APPROVAL  
 X INFORMATION \_\_\_CERTIFIED

DRAWN BY	DATE
CHECKED BY	DATE
SCALE	SIZE
NTS	

**SUPERIOR WATER TECHNOLOGIES**  
 DISINFECTION AND MANAGEMENT SYSTEMS FOR THE MUNICIPAL WATER INDUSTRY  
 WWW.SUPERIORWATERTECHNOLOGIES.COM

PROJECT NAME	TITLE
	VORTEX RESERVOIR MIXING SYSTEM TOWER GENERAL ARRANGEMENT DRAWING
REFERENCE INFORMATION	DRAWING NO

REV	0
SHEET 1 OF 1	



[This page is intentionally left blank.]



**Project name:** Hazen & Sawyer, Mesa Water, Vortex Reservoir Management System

**Proposal No.:** 16120 – Reservoir 2, 18MG Capacity

**Attn:** Tama Snow

**Date:** October 20, 2016

**Proposal Expiration Date:** June 30, 2017

Superior Water Technologies is pleased to offer Hazen and Sawyer this budgetary proposal for the Mesa Water District Reservoir 2 facility. We recommend the following scope of supply to improve water quality with complete and reliable mixing, chemical injection, and residual sampling of stored water.

**Vortex™ Reservoir Management System for Reservoir 2 consisting of the following package:**

**Two (2) Vortex™ Reservoir Mixing System:**

- Secure and lockable powder coated 6061T series corrosion resistant aluminum equipment enclosure with 4 mil white powder coat finish.
- 316 stainless steel mixing unit tower sections.
- FDA grade UHMW PE multi-port mixing nozzle assembly.
- Investment cast 316 stainless steel recirculating pump.
- Premium efficiency wash-down rated pump motor, inverter duty, 15HP, 480VAC, 3PH.
- Mixer control enclosure with Allen Bradley Powerflex 40 VFD, mixer start/stop controls, status indication lights, system power disconnect, and associated control wiring.
- Chemical injection connections for hypochlorite and aqueous ammonia.
- All piping, mounting hardware, seals, and gaskets for a complete packaged system.
- Integral pressurized water sample supply for residual analysis.
- Start-up and training services for Operations staff upon completion of the system installation.

**One (1) SWT SureFeed aqueous ammonia storage and metering system, skid mounted:**

- One (1) 200 gallon ammonia storage tank, 316 stainless steel, with chilling package
- One (1) Ammonia chilling system for 200G tank, 316SS enclosure, closed loop cooling
- Four (4) Ammonia metering pumps, peristaltic, Watson Marlow Q-dos, 2 Duty/2 Stand-by, , 120VAC 1PH
- 316 stainless steel skid, passivated for corrosion resistance, with seismic restraint
- Ammonia tank level transmitter, Guided Wave Radar, Endress+Hauser FMP-51

**Two (2) Sodium Hypochlorite metering system, wall-mounted:**

- Four (4) Hypochlorite metering pumps, peristaltic, 2 Duty/2 Stand-by, Watson Marlow Q-dos, 120VAC 1PH
- 6061T1 Aluminum wall-mount assembly with HDPE mounting deck
- Pump process piping and electrical
- Floor-mount skid assembly is available, if desired

**One (1) 12.5% Bulk Sodium Hypochlorite storage system:**

- Double-contained Hypochlorite storage tank, 1,100 gallon, HDPE, with all fittings
- Tank level transmitter, LU20 ultrasonic system

**One (1) Reservoir Management Control Panel:**

- Allen Bradley MicroLogics PLC
- 10" color touch screen display
- Stainless steel control enclosure
- Superior Water Technologies Reservoir Management System Control Program

**Two (2) Chlorine residual analyzer system:**

- Prominent DC1b Total chlorine residual analyzer with SWT process enhancement
- Wall mount panel
- Operators sample station, with grab sample port, sample drain, and workstation

**Additional services:**

- Start-up and training services for Operations staff upon completion of the system.
- Lifetime technical support is included.
- Operations and service contracts are available.

**Note:** Proposal is for the reservoir management scope of supply above only. Other equipment and services are available if desired and will be quoted separately.

**Exclusions:** All installation, any on site labor or materials, Reservoir systems building, main electrical services and disconnects, building load center. All below grade conduit and chemical chase, electrical wiring and components not supplied above, any item not specifically included in offered scope of supply.

**Warranty:**

Five (5) year warranty on all components located within the reservoir  
Three (3) year warranty on the mixer pump  
Manufacturers' warranty applies to all components not manufactured by SWT

Warranty period to begin on date of system acceptance.

**Budgetary Pricing:**

**Scope of Supply:       \$182,800**

**Pricing does NOT include sales tax**

**Delivery:**

8 to 10 weeks from acceptance of submittals.

**Payment:**

25% invoiced on approval of submittals, 65% on delivery of equipment, 10% on final acceptance. NET 30

**Customer satisfaction and equipment reliability are the top priorities for Superior Water Technologies. We take great pride in providing a premium quality product to our customers, and thank you for the opportunity to provide this proposal.**

Tony Edwards  
Superior Water Technologies  
954-225-7696



**Project name:** Hazen & Sawyer, Mesa Water, Vortex Reservoir Management System

**Proposal No.:** 16120 – Reservoir 1, 10MG Capacity

**Attn:** Tama Snow

**Date:** October 20, 2016

**Proposal Expiration Date:** June 30, 2017

Superior Water Technologies is pleased to offer Hazen and Sawyer this budgetary proposal for the Mesa Water District Reservoir 1 facility. We recommend the following scope of supply to improve water quality with complete and reliable mixing, chemical injection, and residual sampling of stored water.

**Vortex™ Reservoir Management System for Reservoir 1 consisting of the following package:**

**One (1) Vortex™ Reservoir Mixing System:**

- Secure and lockable powder coated 6061T series corrosion resistant aluminum equipment enclosure with 4 mil white powder coat finish.
- 316 stainless steel mixing unit tower sections.
- FDA grade UHMW PE multi-port mixing nozzle assembly.
- Investment cast 316 stainless steel recirculating pump.
- Premium efficiency wash-down rated pump motor, inverter duty, 15HP, 480VAC, 3PH.
- Mixer control enclosure with Allen Bradley Powerflex 40 VFD, mixer start/stop controls, status indication lights, system power disconnect, and associated control wiring.
- Chemical injection connections for hypochlorite and aqueous ammonia.
- All piping, mounting hardware, seals, and gaskets for a complete packaged system.
- Integral pressurized water sample supply for residual analysis.
- Start-up and training services for Operations staff upon completion of the system installation.

**One (1) SWT SureFeed aqueous ammonia storage and metering system, skid mounted:**

- One (1) 200 gallon ammonia storage tank, 316 stainless steel, with chilling package
- One (1) Ammonia chilling system for 200G tank, 316SS enclosure, closed loop cooling
- Two (2) Ammonia metering pumps, peristaltic, Watson Marlow Q-dos, 1 Duty/1 Stand-by, , 120VAC 1PH
- 316 stainless steel skid, passivated for corrosion resistance, with seismic restraint
- Ammonia tank level transmitter, Guided Wave Radar, Endress+Hauser FMP-51

**One (1) Sodium Hypochlorite metering system, wall-mounted:**

- Two (2) Hypochlorite metering pumps, peristaltic, 1 Duty/1 Stand-by, Watson Marlow Q-dos, 120VAC 1PH
- 6061T1 Aluminum wall-mount assembly with HDPE mounting deck
- Pump process piping and electrical
- Floor-mount skid assembly is available, if desired

**One (1) 12.5% Bulk Sodium Hypochlorite storage system:**

- Double-contained Hypochlorite storage tank, 1,100 gallon, HDPE, with all fittings
- Tank level transmitter, LU20 ultrasonic system

**One (1) Reservoir Management Control Panel:**

- Allen Bradley MicroLogics PLC
- 10" color touch screen display
- Stainless steel control enclosure
- Superior Water Technologies Reservoir Management System Control Program

**One (1) Chlorine residual analyzer system:**

- Prominent DC1b Total chlorine residual analyzer with SWT process enhancement
- Wall mount panel
- Operators sample station, with grab sample port, sample drain, and workstation

**Additional services:**

- Start-up and training services for Operations staff upon completion of the system.
- Lifetime technical support is included.
- Operations and service contracts are available.

**Note:** Proposal is for the reservoir management scope of supply above only. Other equipment and services are available if desired and will be quoted separately.

**Exclusions:** All installation, any on site labor or materials, Reservoir systems building, main electrical services and disconnects, building load center. All below grade conduit and chemical chase, electrical wiring and components not supplied above, any item not specifically included in offered scope of supply.

**Warranty:**

Five (5) year warranty on all components located within the reservoir  
Three (3) year warranty on the mixer pump  
Manufacturers' warranty applies to all components not manufactured by SWT

Warranty period to begin on date of system acceptance.

**Budgetary Pricing:**

**Scope of Supply:       \$131,900**

**Pricing does NOT include sales tax**

**Delivery:**

8 to 10 weeks from acceptance of submittals.

**Payment:**

25% invoiced on approval of submittals, 65% on delivery of equipment, 10% on final acceptance. NET 30

**Customer satisfaction and equipment reliability are the top priorities for Superior Water Technologies. We take great pride in providing a premium quality product to our customers, and thank you for the opportunity to provide this proposal.**

Tony Edwards  
Superior Water Technologies  
954-225-7696

## **Appendix B - Chemical Feed System and Mixing System P&ID**



[This page is intentionally left blank.]

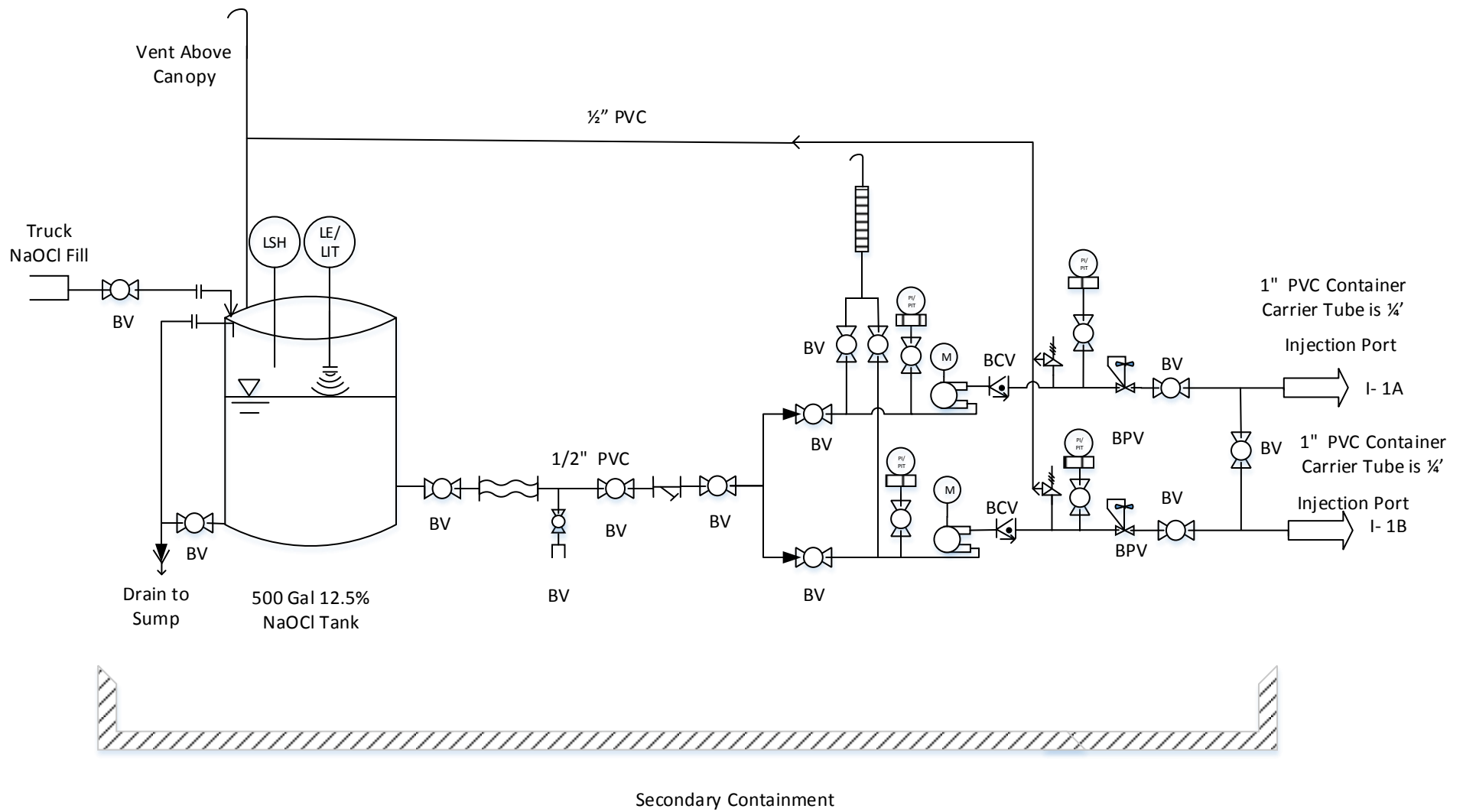

Sodium Hypochlorite Storage Tank and P&ID

[This page is intentionally left blank.]

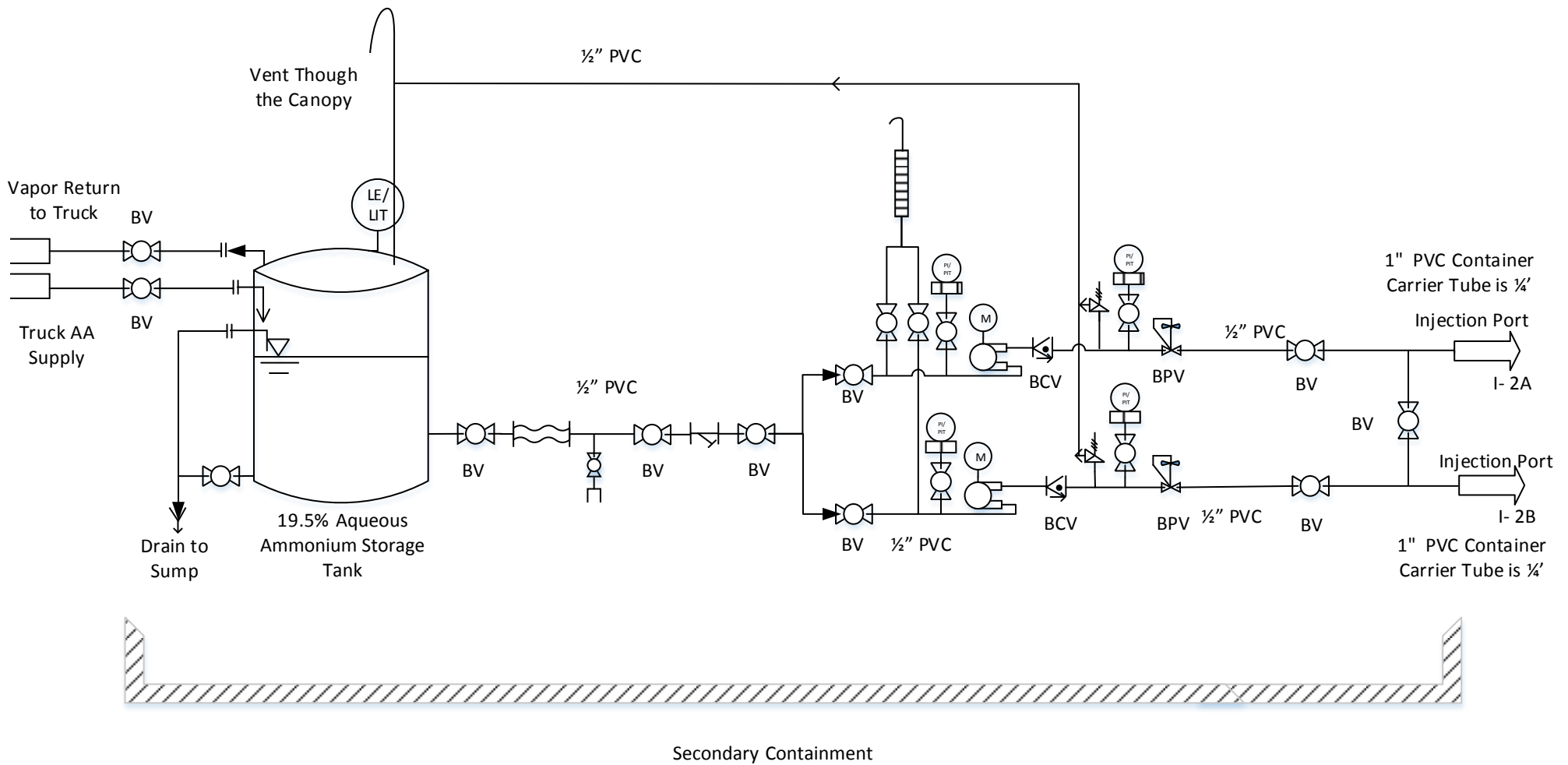

Aqueous Ammonia Storage Tank and P&ID

[This page is intentionally left blank.]

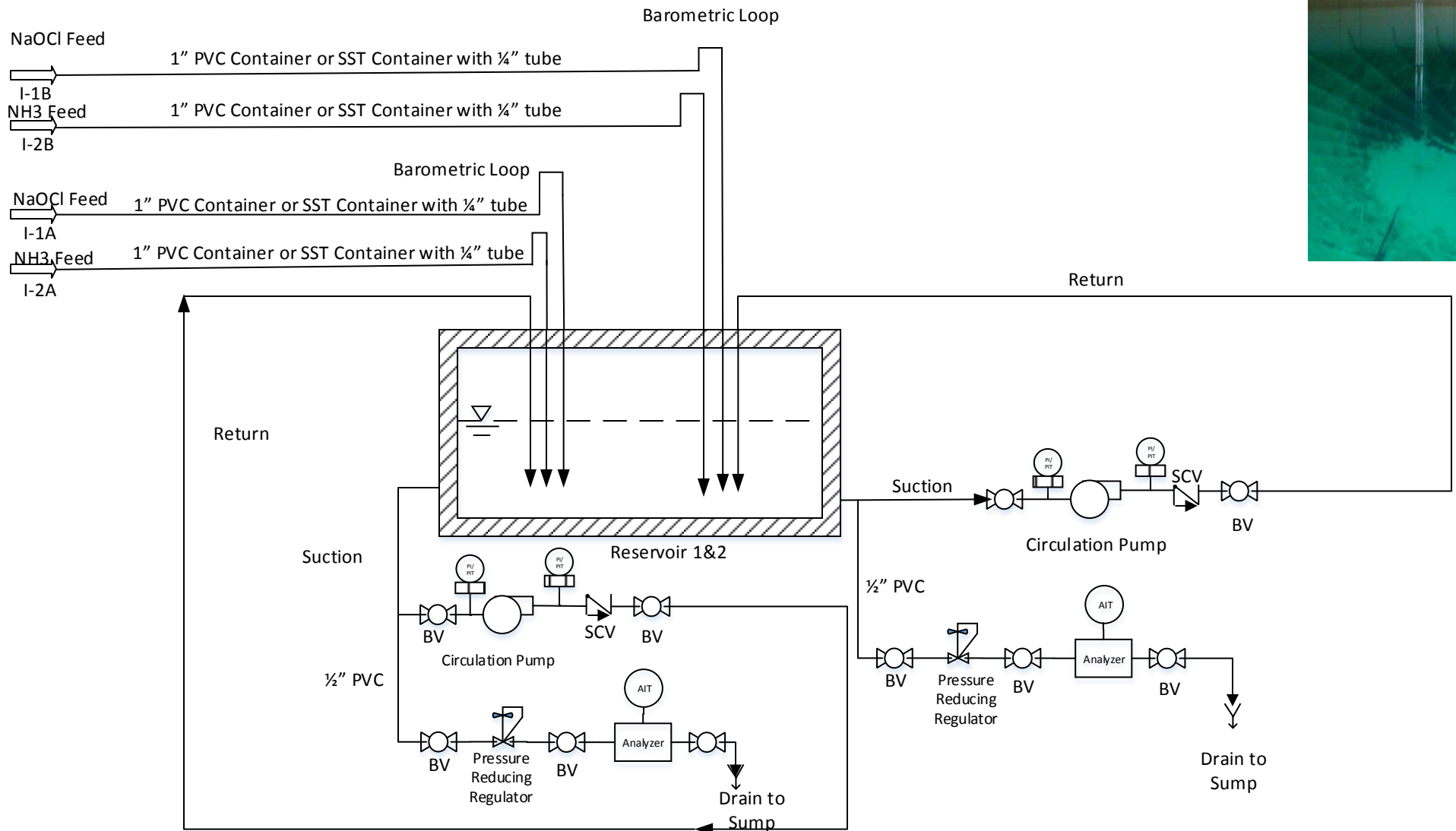

Reservoir 1&2 option 1: Vortex Chemical Addition and Recirculation Pumps

[This page is intentionally left blank.]

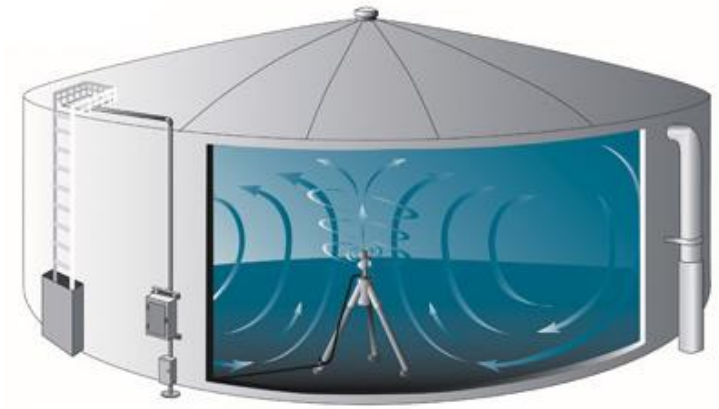
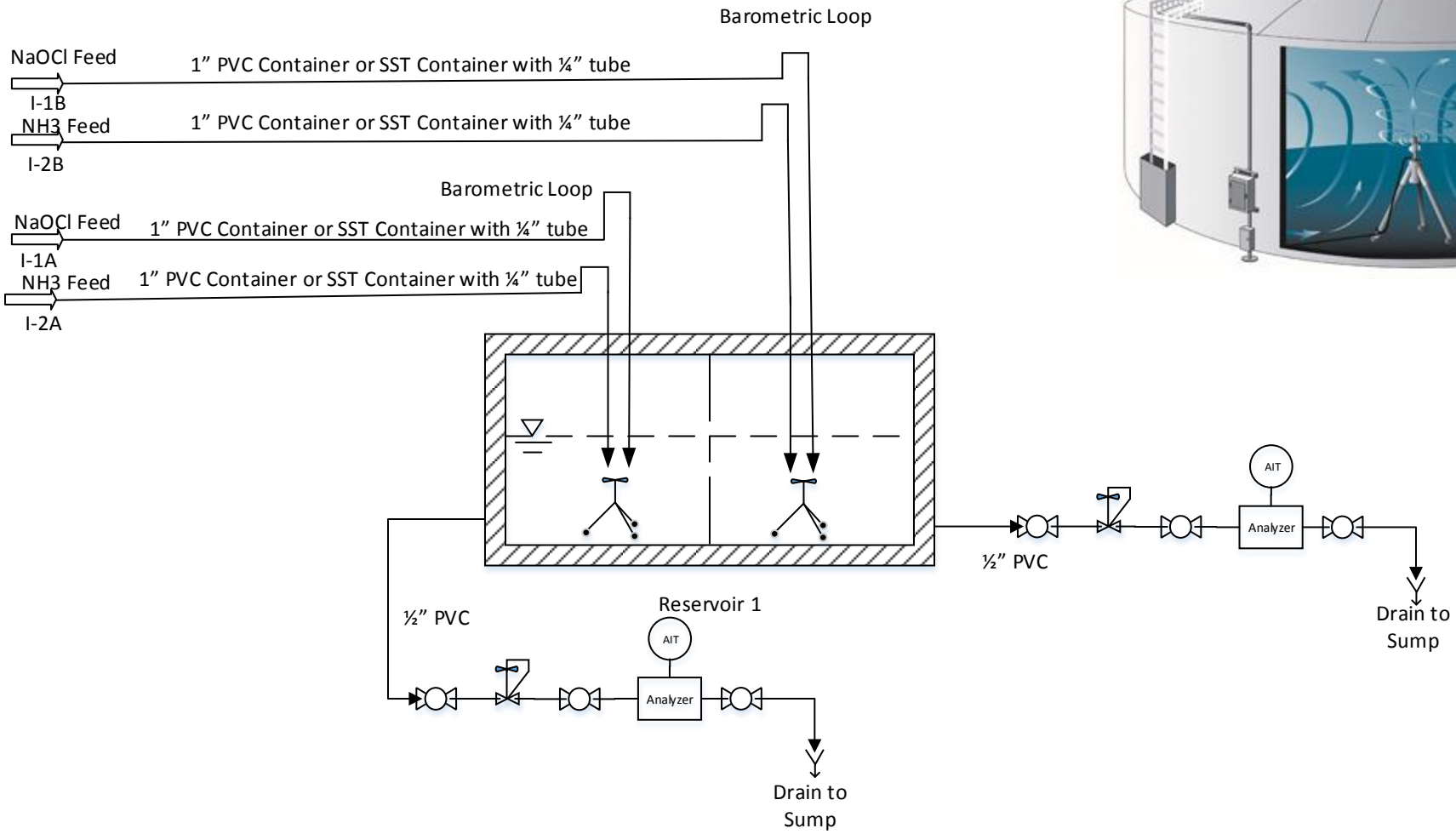

Reservoir 1 option 2: PAX Mixing



[This page is intentionally left blank.]

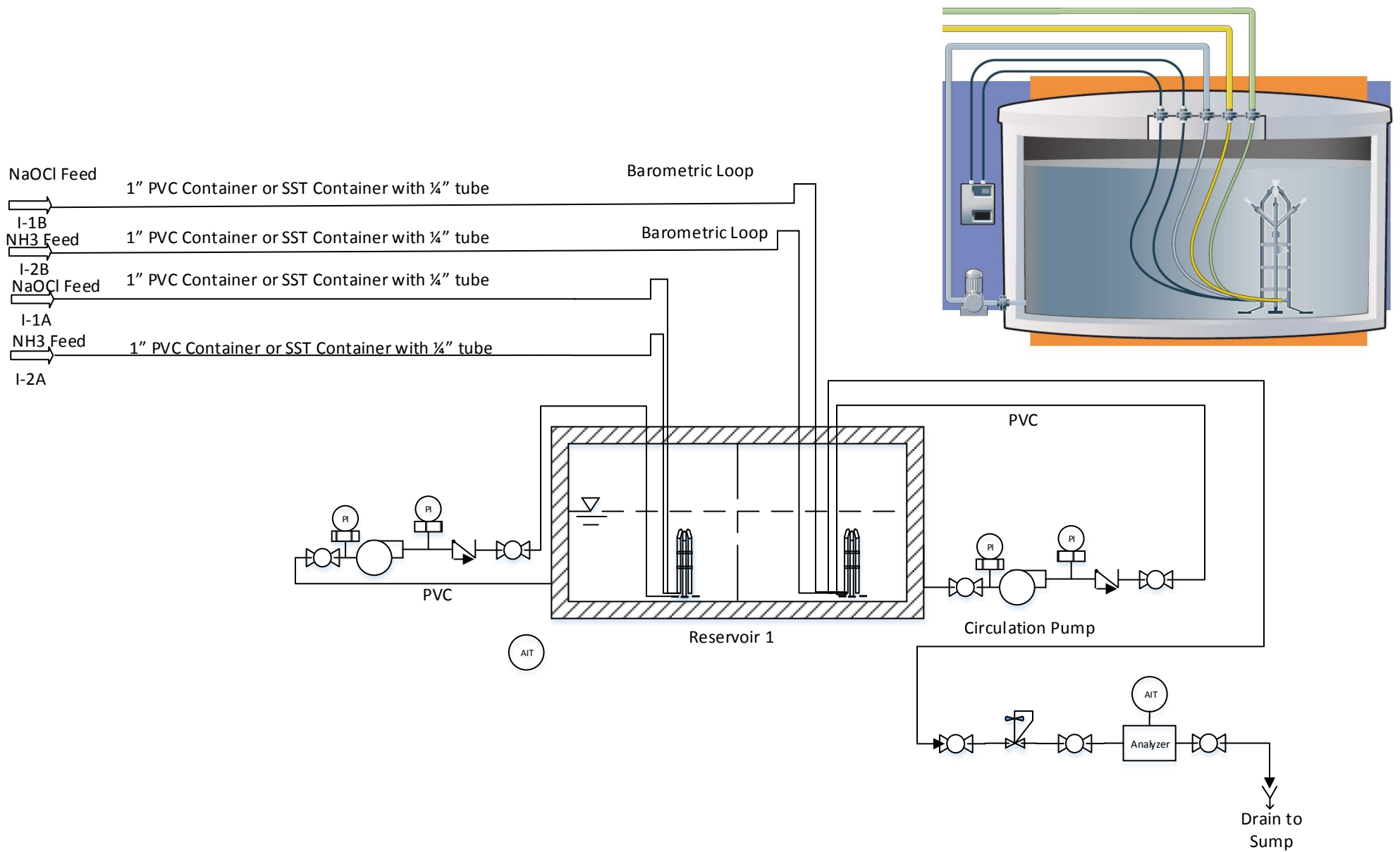

Reservoir 1 option 3: Tank Shark Chemical Addition and Recirculation Pumps

[This page is intentionally left blank.]

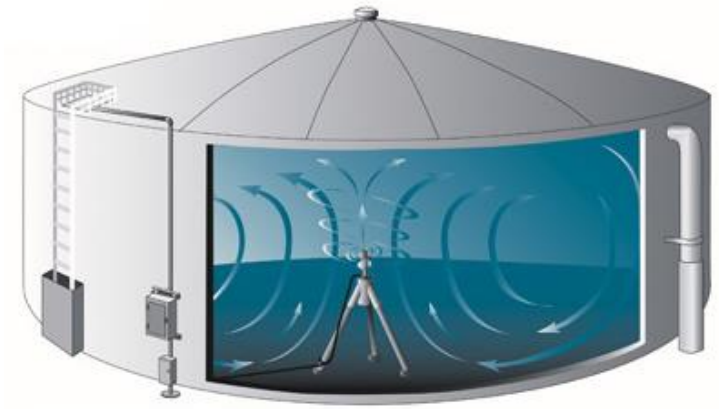
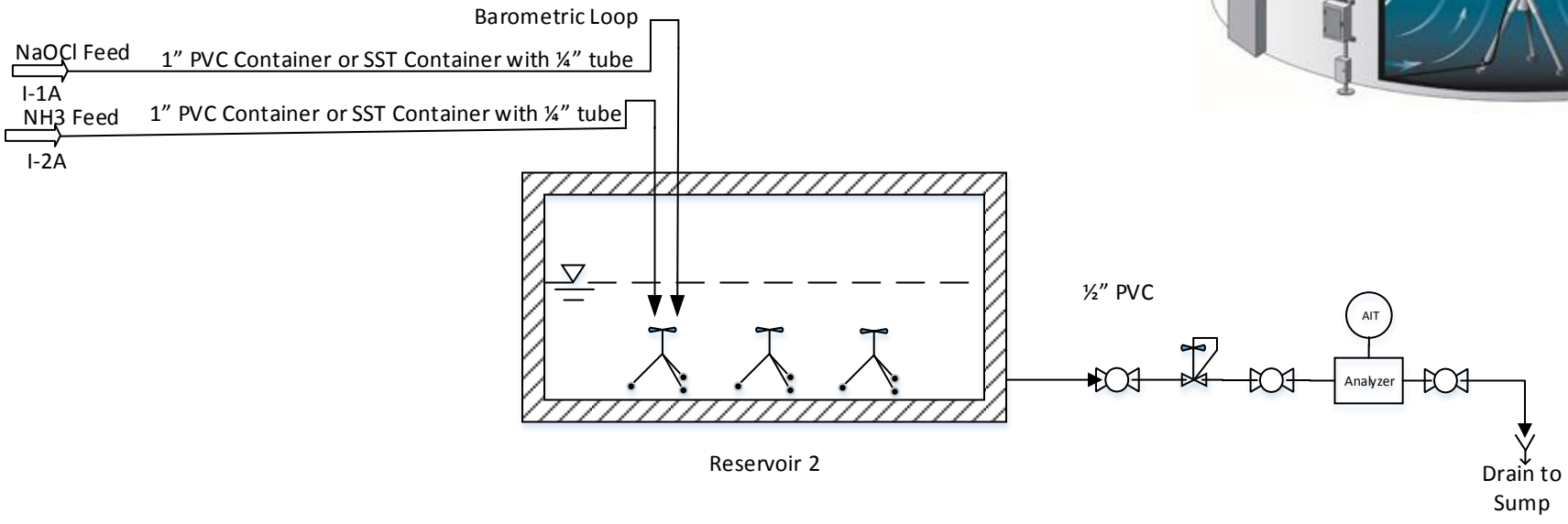

Reservoir 2 option 2: PAX Mixing

[This page is intentionally left blank.]

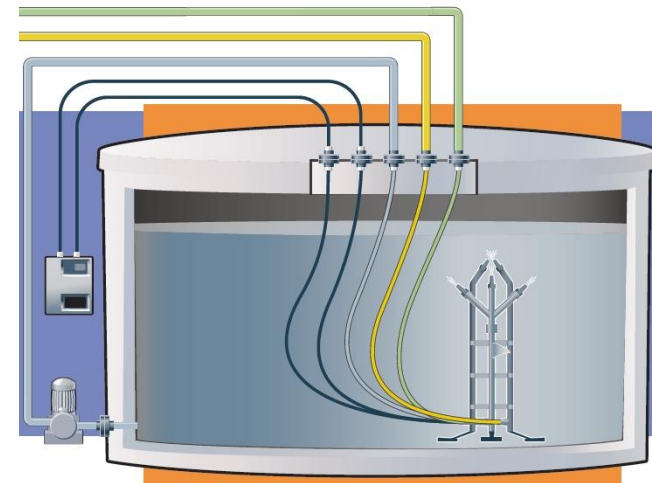
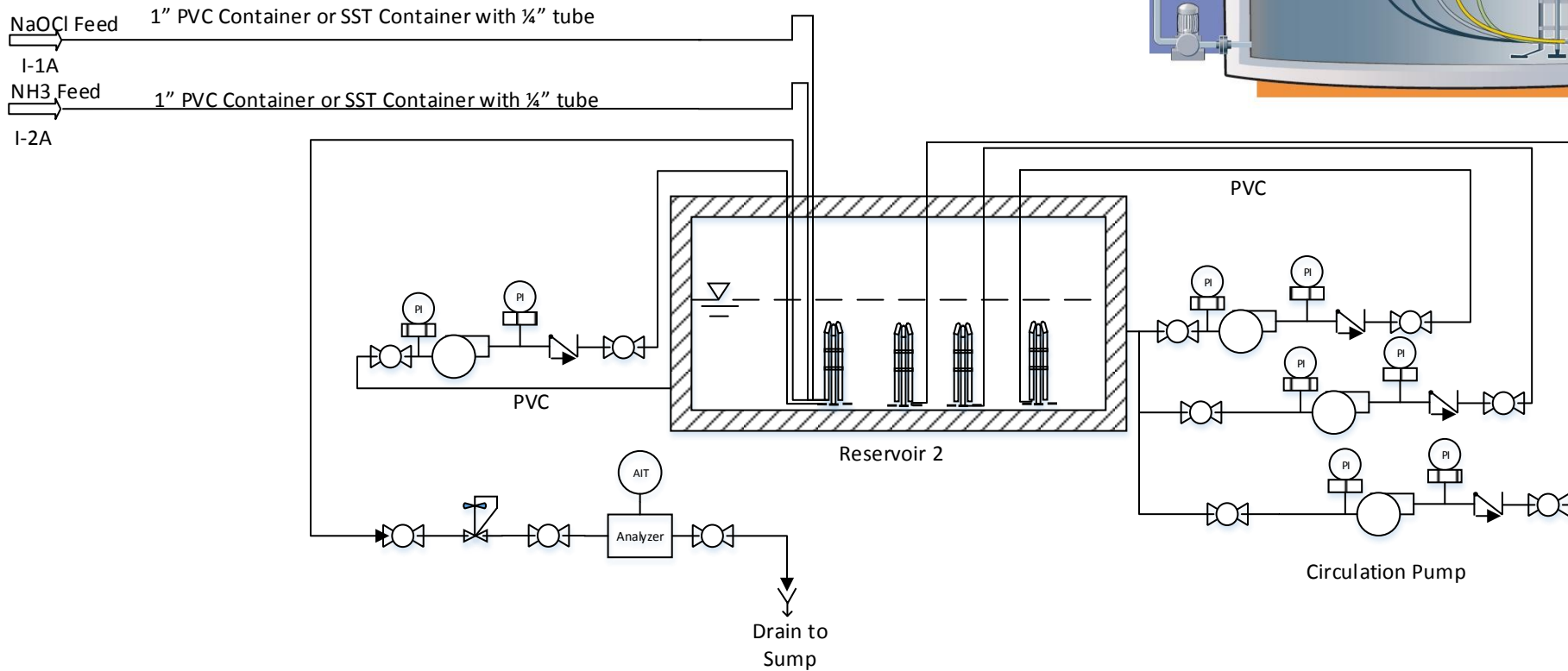

Reservoir 2 option 3: Tank Shark Chemical Addition and Recirculation Pumps

[This page is intentionally left blank.]

## **Appendix C - 30 % Construction Drawings**



[This page is intentionally left blank.]

# MESA WATER DISTRICT COSTA MESA, CALIFORNIA



## RESERVOIR 1 & 2 PUMPS, CONTROLS, AND CHEMICAL SYSTEM ASSESSMENT PROJECT - CHEMICAL DOSING SYSTEM AND WATER QUALITY MONITORING

OCTOBER 2017

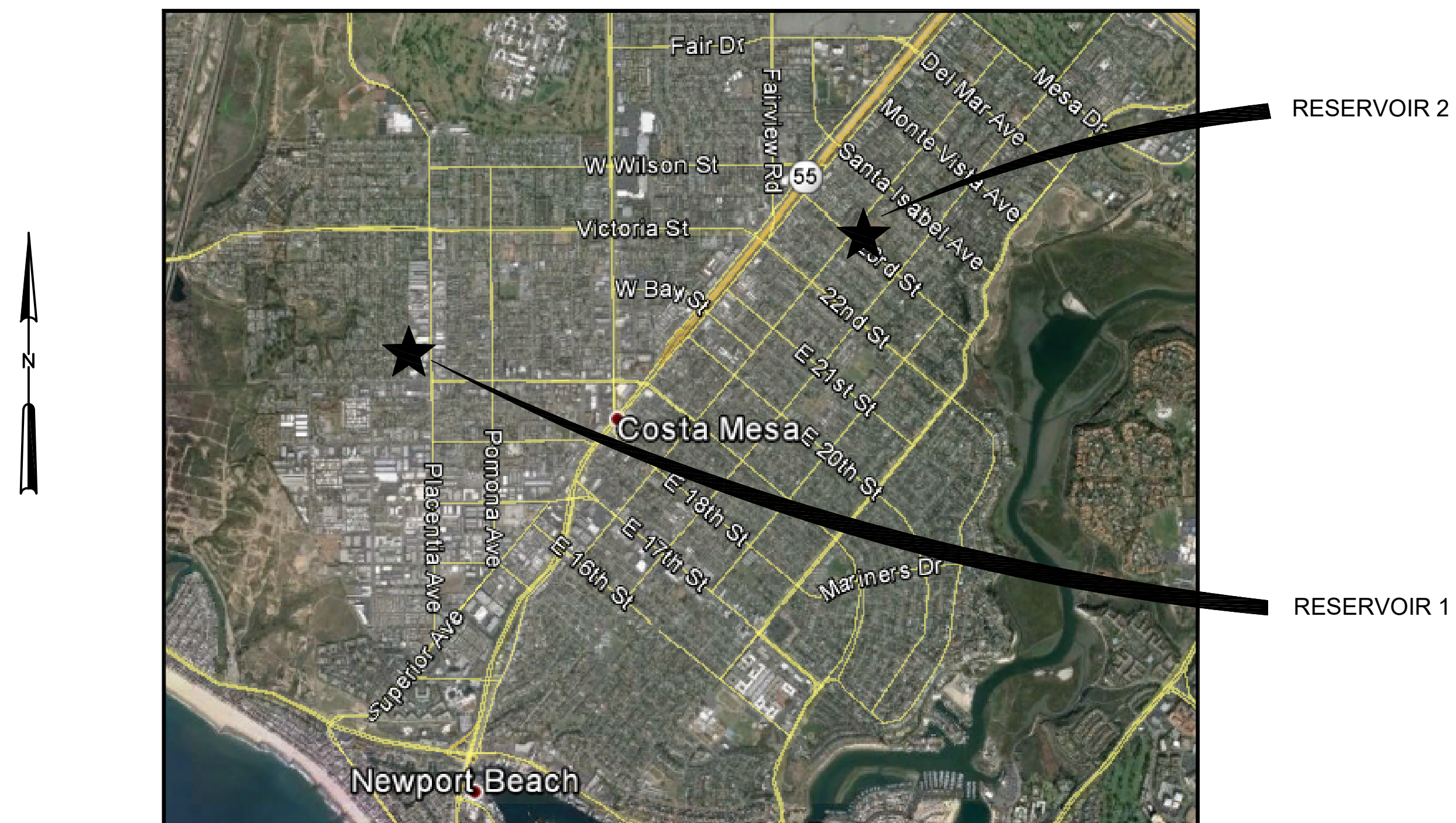

LOCATION MAP

# Hazen

HAZEN AND SAWYER  
7700 IRVINE CENTER DRIVE, SUITE 200  
IRVINE, CA 92618

[This page is intentionally left blank.]

SHEET INDEX

Table with 2 columns: SHEET NO. and TITLE. Lists sheets for GENERAL, CIVIL, MECHANICAL, and RESERVOIR 1 & 2.

GENERAL

Table listing general abbreviations such as AB (ANCHOR BOLT), AC (ASBESTOS CEMENT), AD (AREA DRAIN), etc.

EL

Table listing electrical abbreviations such as ELEC (ELECTRICAL), ELP (EMERGENCY LIGHTING PANEL), etc.

LS

Table listing level and lighting abbreviations such as LTG (LIGHTING), LWL (LOW WATER LEVEL), etc.

SCH

Table listing schedule abbreviations such as SLUICE GATE, SECTION, SERVICE, etc.

CPLG

Table listing coupling abbreviations such as COUPLING, ECCENTRIC JOINT, EXPANSION JOINT, etc.

PIPING MATERIALS

Table listing piping materials abbreviations such as CIP (CAST IRON PIPE), CMP (CORRUGATED METAL PIPE), etc.

PROCESS PIPING

Table listing process piping abbreviations such as A (PROCESS AIR), AMFP (AMMONIA FEED PUMP), etc.

VALVES, FITTINGS, ETC.

Table listing valve and fitting abbreviations such as ARV (AIR RELIEF VALVE), ARVT (AIR RELEASE VALVE VAULT), etc.

LEGEND

Legend table with columns for SYMBOLS, MATERIALS, and LINETYPES. Includes symbols for BALL VALVE, BUTTERFLY VALVE, CHECK VALVE, etc., and material patterns for GRADE OR EARTH, ASPHALT PAVING, CAST IRON, etc.

SECTION AND DETAIL KEYING

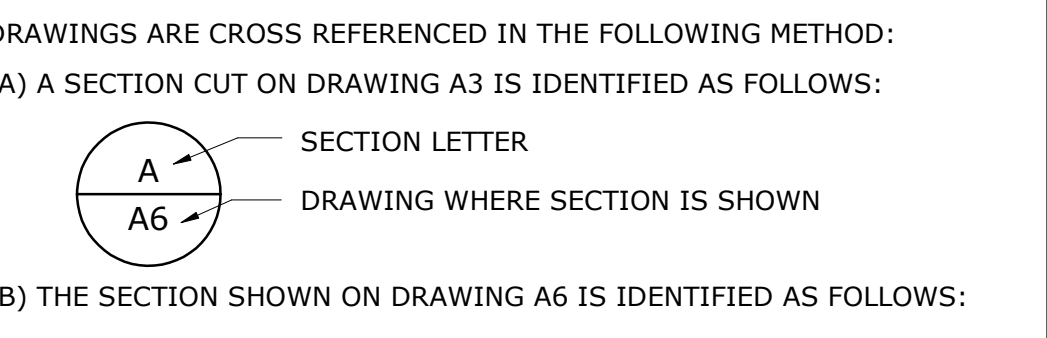

Text explaining how details are cross-referenced and how standard details are referenced by a unique seven-digit number.

ROOM NAME LABEL

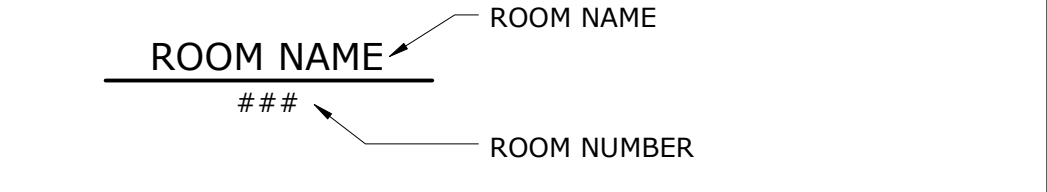

LINETYPES

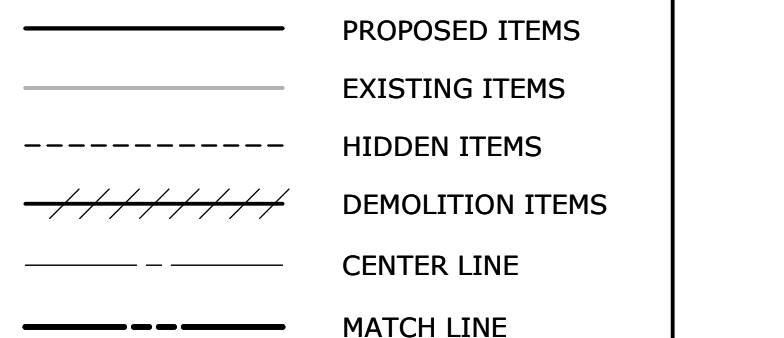

ELEVATION CALL OUT

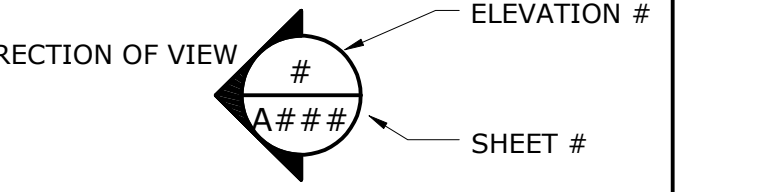

Vertical text on the left edge: PLOT DATE: 2017/10/23 8:37:05 AM...

Table for revision control with columns: REV, ISSUED FOR, DATE, BY.

Table with project details: PROJECT ENGINEER: KLA, DESIGNED BY: TSS, DRAWN BY: CFW, CHECKED BY: TSS.

30% SUBMITTAL DO NOT USE FOR CONSTRUCTION



MESA WATER DISTRICT COSTA MESA, CALIFORNIA. RESERVOIR 1 & 2 PUMPS, CONTROLS, AND CHEMICAL SYSTEM ASSESSMENT PROJECT - CHEMICAL DOSING SYSTEM AND WATER QUALITY MONITORING

GENERAL SHEET INDEX, LEGEND, SYMBOLS AND ABBREVIATIONS

Table with project metadata: DATE: OCTOBER 2017, HAZEN NO.: 20035-001, CONTRACT NO.: 1, DRAWING NUMBER: G-02.

[This page is intentionally left blank.]

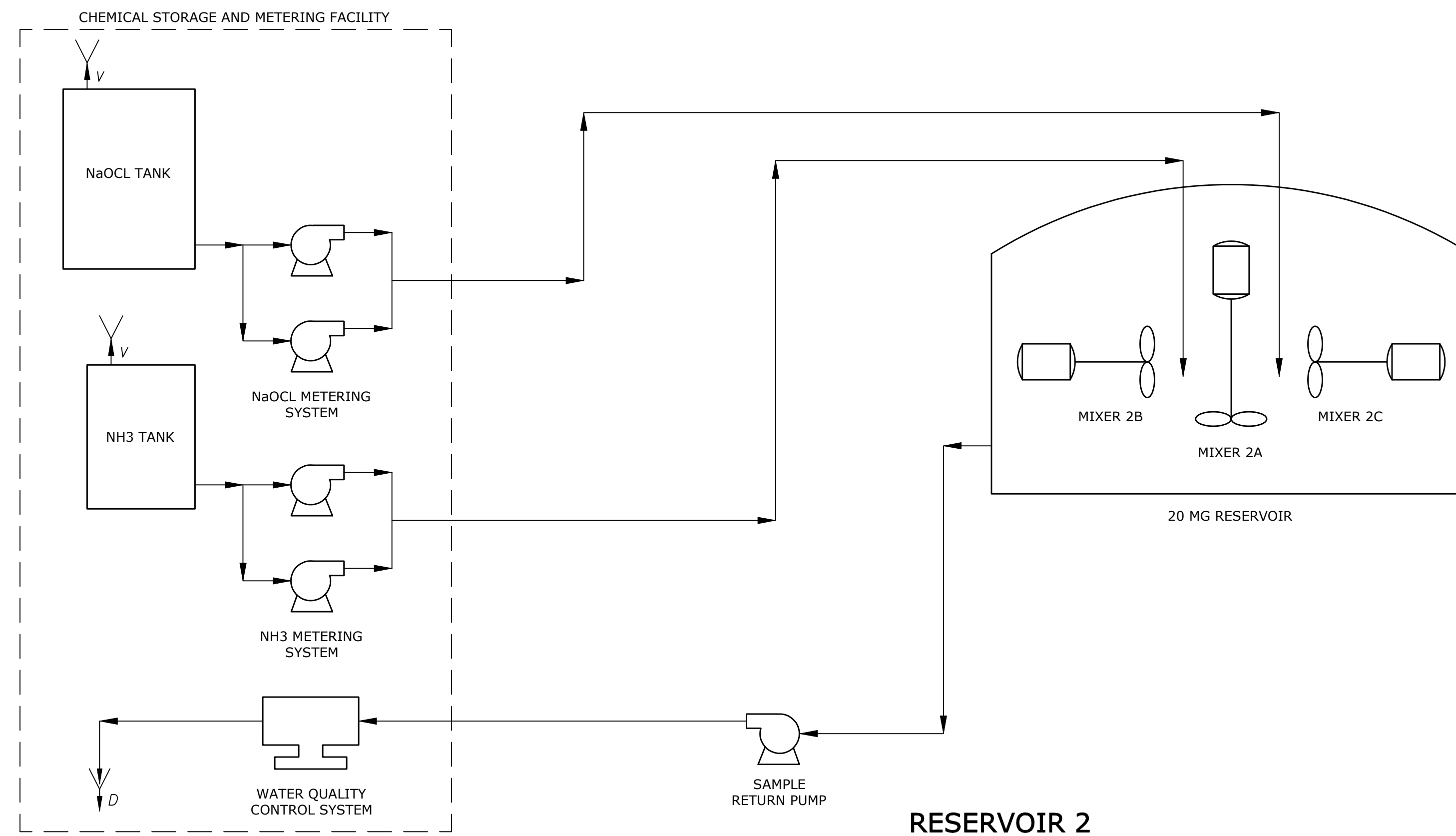
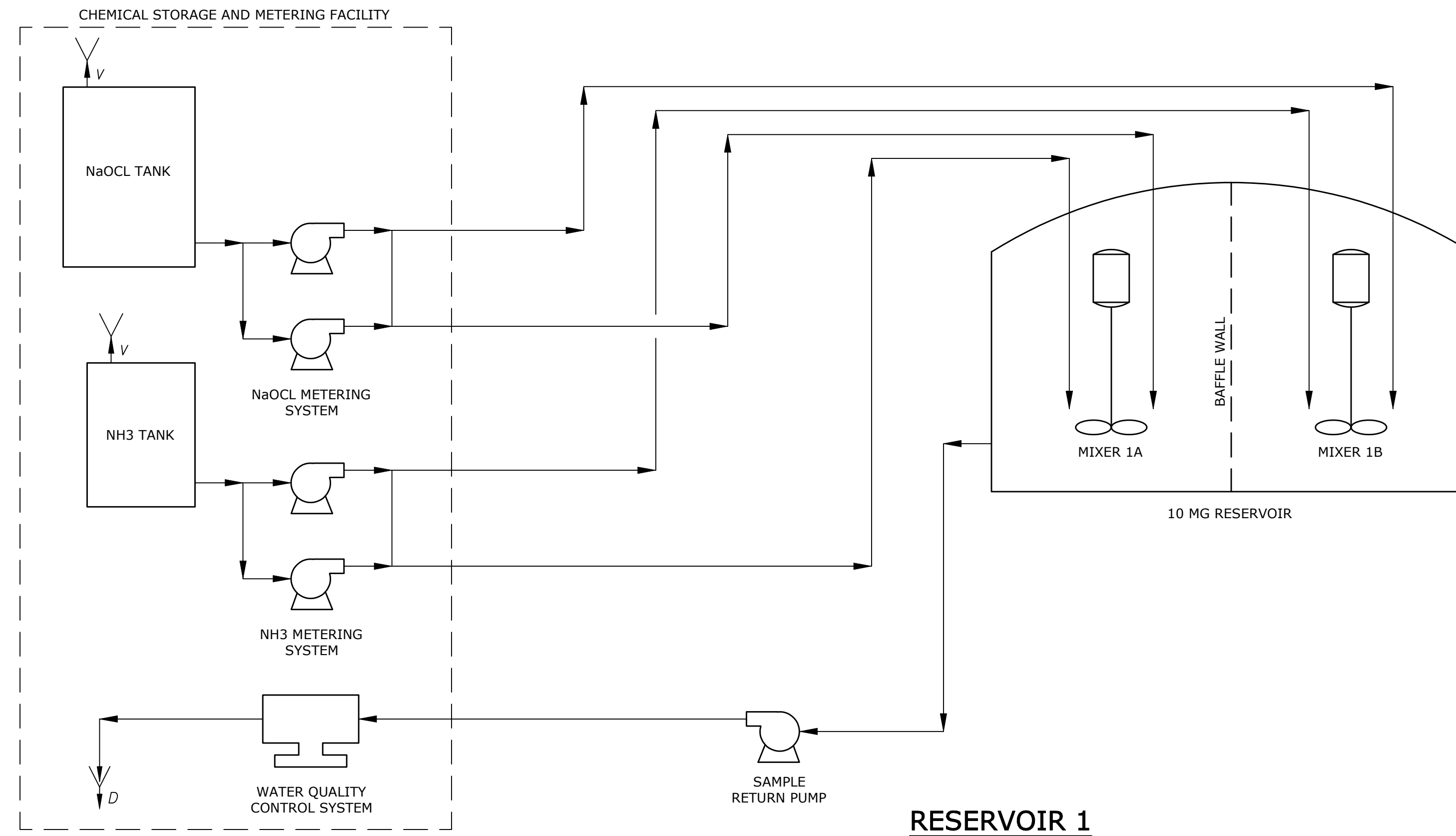

PLOT DATE: 2017/10/23 9:57:07 AM  
 PLOT BY: J. GARCIA  
 PLOT FROM: C:\Users\jgarcia\OneDrive\Documents\20035-001\_G-03\_Saved By: DWIT\_Sam Date: 2017/09/16 11:12 PM

REV	ISSUED FOR	DATE	BY

PROJECT ENGINEER:	KLA
DESIGNED BY:	TSS
DRAWN BY:	CFW
CHECKED BY:	TSS
IF THIS BAR DOES NOT MEASURE 1" THEN DRAWING IS NOT TO FULL SCALE 	

30% SUBMITTAL  
 DO NOT USE FOR  
 CONSTRUCTION



MESA WATER DISTRICT  
 COSTA MESA, CALIFORNIA  
 RESERVOIR 1 & 2 PUMPS, CONTROLS, AND  
 CHEMICAL SYSTEM ASSESSMENT PROJECT -  
 CHEMICAL DOSING SYSTEM AND  
 WATER QUALITY MONITORING

GENERAL  
 PROCESS FLOW DIAGRAMS

DATE:	OCTOBER 2017
HAZEN NO.:	20035-001
CONTRACT NO.:	1
DRAWING NUMBER:	G-03

[This page is intentionally left blank.]

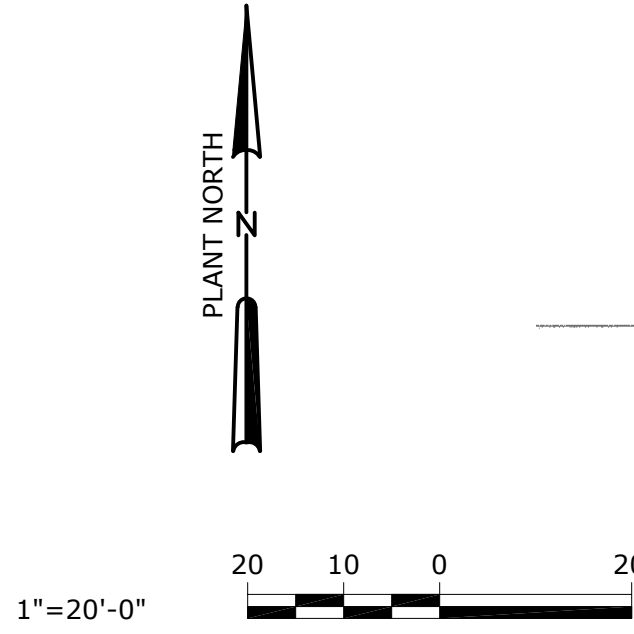
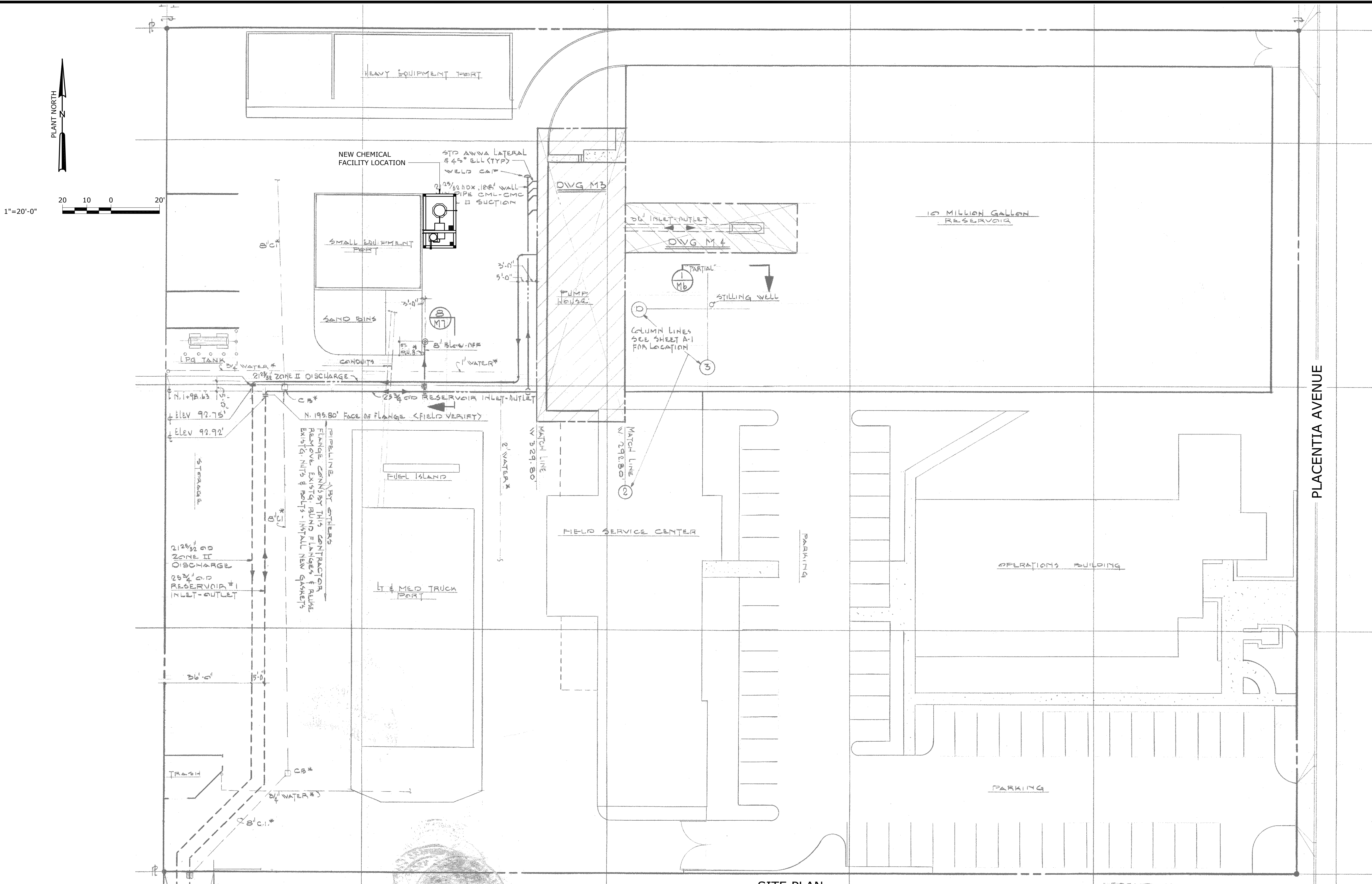

SITE PLAN  
1" = 20'  
LEGEND

PLOT DATE: 2017/10/23 8:45:04 AM  
 FILE: C:\Users\jgarcia\Desktop\2017\20170911\20170911.dwg  
 Saved By: DWT  
 Save Date: 2017/10/11 11:28 AM

REV	ISSUED FOR	DATE	BY

PROJECT ENGINEER:	KLA
DESIGNED BY:	TSS
DRAWN BY:	CFW
CHECKED BY:	TSS
IF THIS BAR DOES NOT MEASURE 1" THEN DRAWING IS NOT TO FULL SCALE	

30% SUBMITTAL  
DO NOT USE FOR  
CONSTRUCTION



CIVIL SEAL



**Hazen**  
HAZEN AND SAWYER  
7700 IRVINE CENTER DRIVE, SUITE 200  
IRVINE, CA 92618

MESA WATER DISTRICT  
COSTA MESA, CALIFORNIA

RESERVOIR 1 & 2 PUMPS, CONTROLS, AND  
CHEMICAL SYSTEM ASSESSMENT PROJECT -  
CHEMICAL DOSING SYSTEM AND  
WATER QUALITY MONITORING

CIVIL  
RESERVOIR 1  
SITE PLAN

DATE:	OCTOBER 2017
HAZEN NO.:	20035-001
CONTRACT NO.:	1
DRAWING NUMBER:	C-100



[This page is intentionally left blank.]

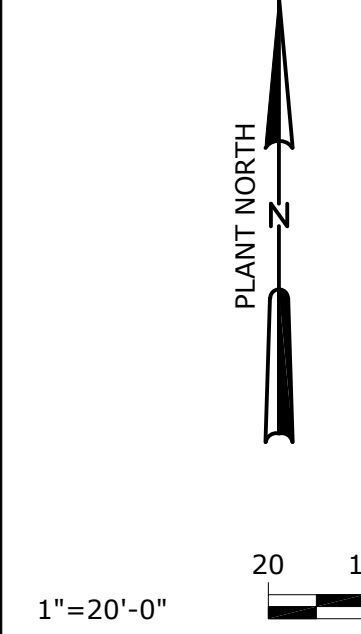
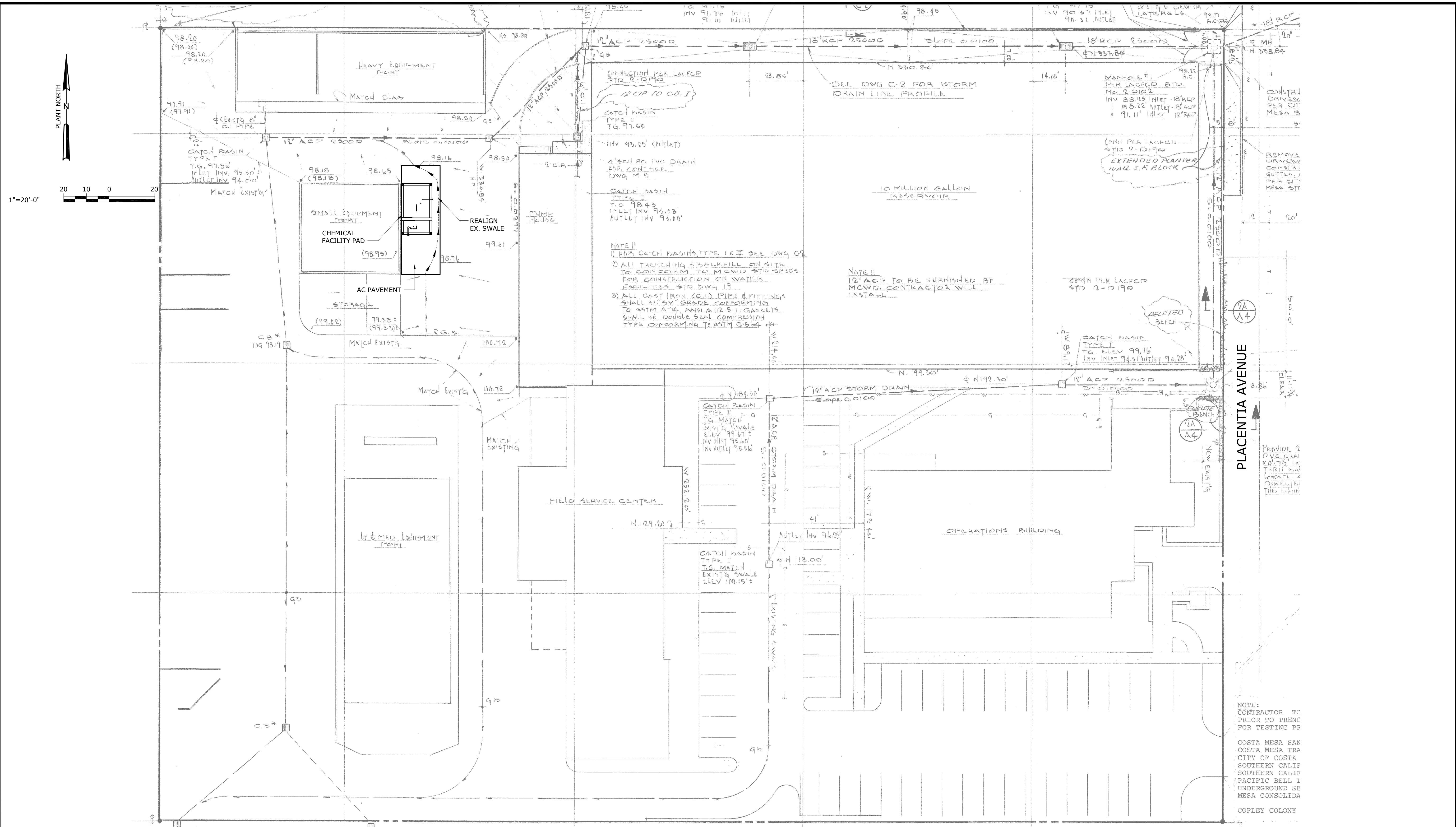

**GRADING AND PAVING PLAN**  
1" = 20'

PLOT DATE: 2017/10/23 9:50:18 AM  
 FILE: C:\Users\jwagner\OneDrive\Documents\CAD\Projects\2017\10\23\102317\102317.dwg  
 Saved By: DWTT  
 Scale Date: 2017/10/21 11:32 AM

REV	ISSUED FOR	DATE	BY

PROJECT ENGINEER:	KLA
DESIGNED BY:	TSS
DRAWN BY:	CFW
CHECKED BY:	TSS
IF THIS BAR DOES NOT MEASURE 1" THEN DRAWING IS NOT TO FULL SCALE	

30% SUBMITTAL  
DO NOT USE FOR  
CONSTRUCTION

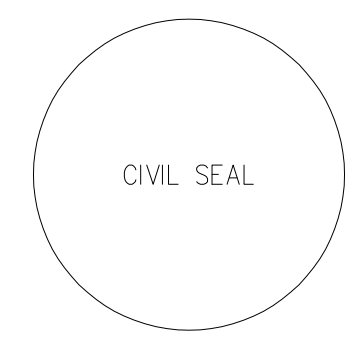

**Hazen**  
HAZEN AND SAWYER  
7700 IRVINE CENTER DRIVE, SUITE 200  
IRVINE, CA 92618

MESA WATER DISTRICT  
COSTA MESA, CALIFORNIA

RESERVOIR 1 & 2 PUMPS, CONTROLS, AND  
CHEMICAL SYSTEM ASSESSMENT PROJECT -  
CHEMICAL DOSING SYSTEM AND  
WATER QUALITY MONITORING

CIVIL  
RESERVOIR 1  
GRADING AND PAVING PLAN

DATE:	OCTOBER 2017
HAZEN NO.:	20035-001
CONTRACT NO.:	1
DRAWING NUMBER:	C-101

[This page is intentionally left blank.]

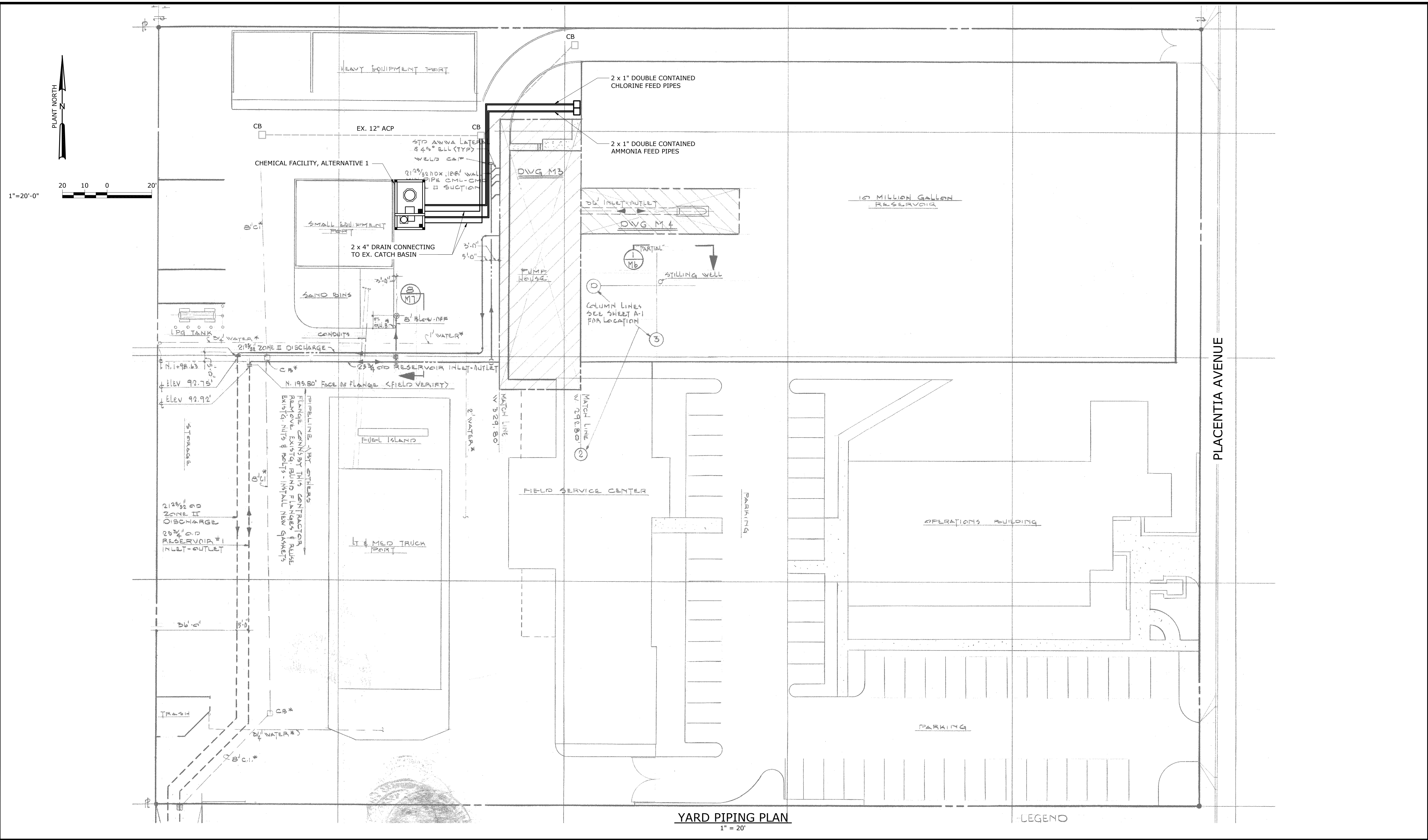

**YARD PIPING PLAN**  
1" = 20'

-LEGEND-

PLOT DATE: 2017/10/23 9:50:10 AM BY: DMIT  
 FILE: C:\Users\dmitt\OneDrive\Documents\CAD\2017\2017-10-23\2017-10-23.dwg Saved By: DMIT Save Date: 2017/10/21 11:30 AM

REV	ISSUED FOR	DATE	BY

PROJECT ENGINEER:	KLA
DESIGNED BY:	TSS
DRAWN BY:	CFW
CHECKED BY:	TSS
IF THIS BAR DOES NOT MEASURE 1" THEN DRAWING IS NOT TO FULL SCALE	

30% SUBMITTAL  
DO NOT USE FOR  
CONSTRUCTION

CIVIL SEAL

Hazen

HAZEN AND SAWYER  
7700 IRVINE CENTER DRIVE, SUITE 200  
IRVINE, CA 92618

MESA WATER DISTRICT  
COSTA MESA, CALIFORNIA

RESERVOIR 1 & 2 PUMPS, CONTROLS, AND  
CHEMICAL SYSTEM ASSESSMENT PROJECT -  
CHEMICAL DOSING SYSTEM AND  
WATER QUALITY MONITORING

CIVIL  
RESERVOIR 1  
YARD PIPING

DATE:	OCTOBER 2017
HAZEN NO.:	20035-001
CONTRACT NO.:	1
DRAWING NUMBER:	C-102

[This page is intentionally left blank.]

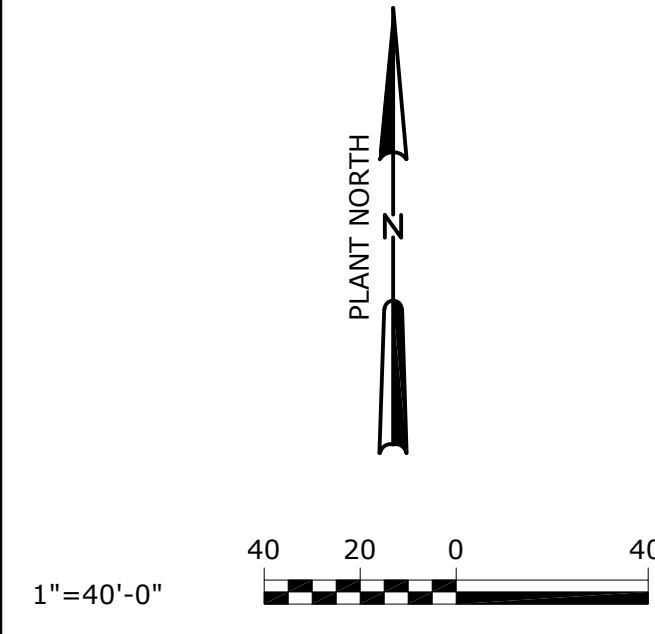
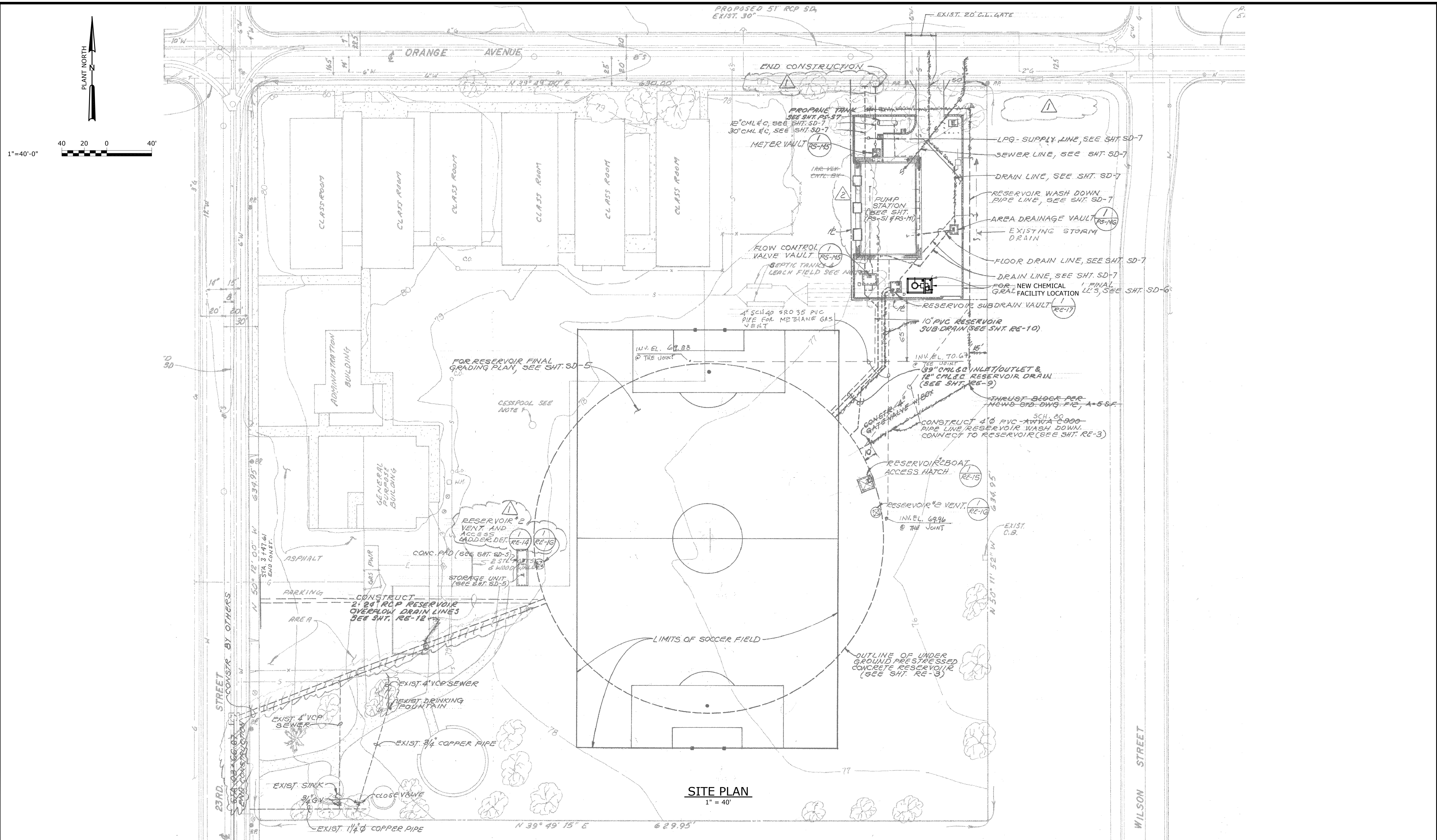

**SITE PLAN**  
1" = 40'

PLOT DATE: 2017/10/23 9:56:10 AM  
 FILE: C:\Users\jwagner\OneDrive\Documents\20035\20035-001\20035-001.dwg  
 Scale: By: DMT  
 Date: 2017/06/16 11:36 PM

REV	ISSUED FOR	DATE	BY

PROJECT ENGINEER:	KLA
DESIGNED BY:	TSS
DRAWN BY:	CFW
CHECKED BY:	TSS
IF THIS BAR DOES NOT MEASURE 1" THEN DRAWING IS NOT TO FULL SCALE	

30% SUBMITTAL  
DO NOT USE FOR  
CONSTRUCTION



**Hazen**  
HAZEN AND SAWYER  
7700 IRVINE CENTER DRIVE, SUITE 200  
IRVINE, CA 92618

MESA WATER DISTRICT  
COSTA MESA, CALIFORNIA  
RESERVOIR 1 & 2 PUMPS, CONTROLS, AND  
CHEMICAL SYSTEM ASSESSMENT PROJECT -  
CHEMICAL DOSING SYSTEM AND  
WATER QUALITY MONITORING

CIVIL  
RESERVOIR 2  
SITE PLAN

DATE:	OCTOBER 2017
HAZEN NO.:	20035-001
CONTRACT NO.:	1
DRAWING NUMBER:	C-200

[This page is intentionally left blank.]

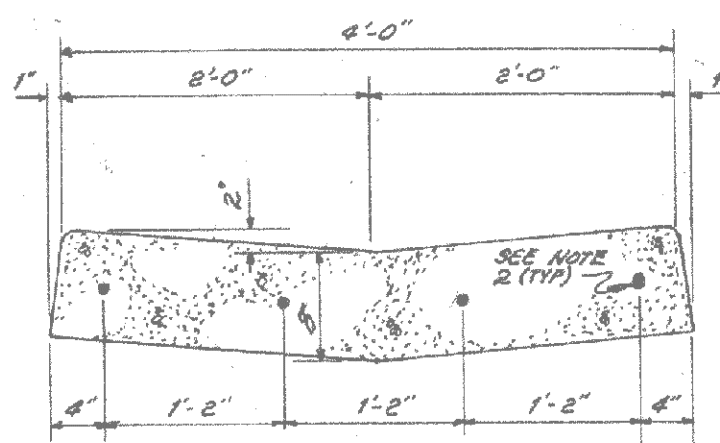
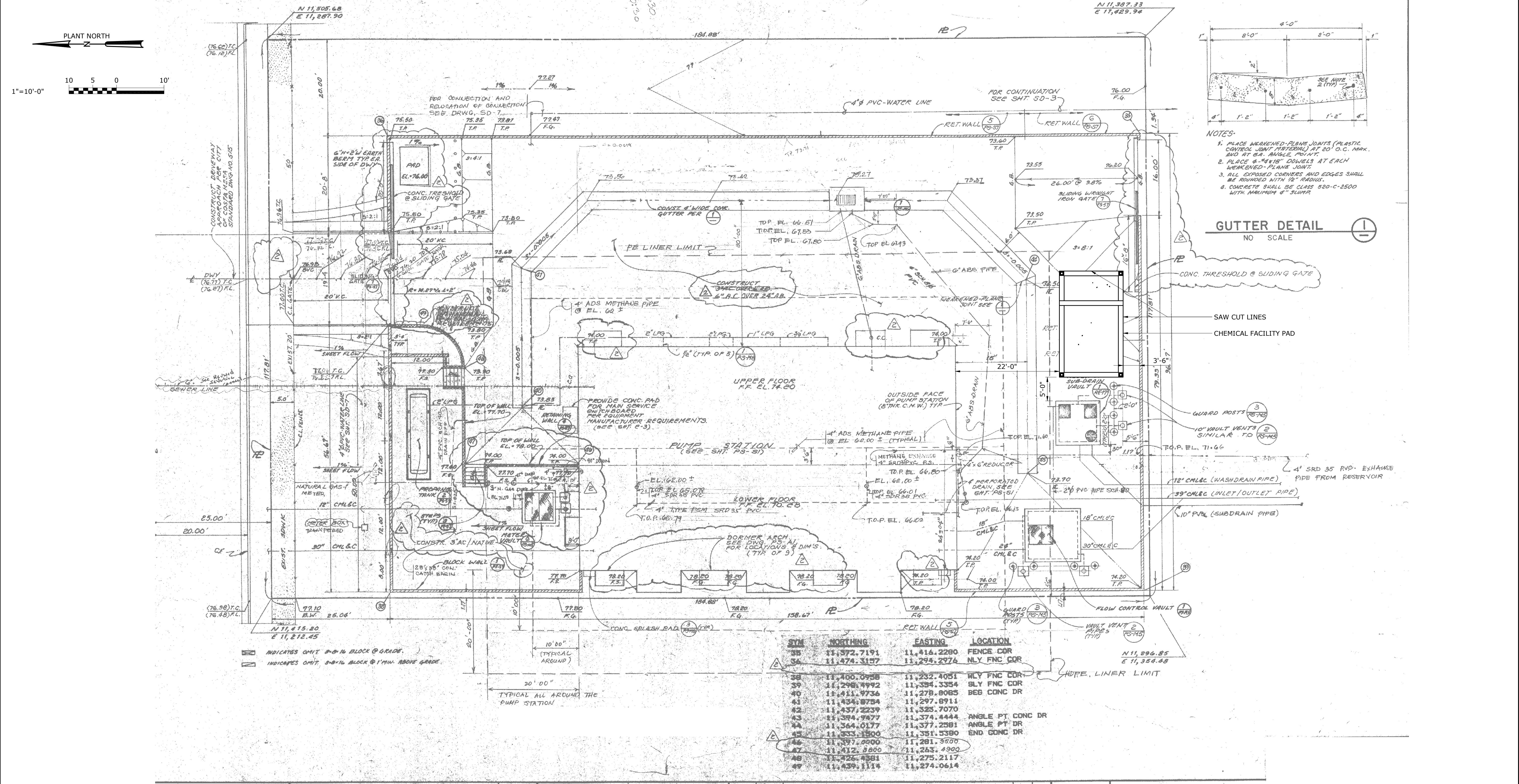

**NOTES:**

1. PLACE WEAKENED-PLANE JOINTS (PLASTIC CONTROL JOINT MATERIAL) AT 20' O.C. MAX. AND AT 90° ANGLE JOINTS.
2. PLACE 4"x18" DOWELS AT EACH WEAKENED-PLANE JOINT.
3. ALL EXPOSED CORNERS AND EDGES SHALL BE ROUNDED WITH 12" RADIUS.
4. CONCRETE SHALL BE CLASS 520-C-2500 WITH MAXIMUM 8" SLUMP.

**GUTTER DETAIL**  
NO SCALE

SAW CUT LINES  
CHEMICAL FACILITY PAD

WARD POSTS (3)  
10' VAULT VENTS (2) SIMILAR TO 25-105

4" SRD 35 PVD EXHAUST PIPE FROM RESERVOIR  
18" CMLEC (WASH/RAIN PIPE)  
39" CMLEC (INLET/OUTLET PIPE)  
10" PVC (SUBDRAIN PIPE)

STN	NORTHING	EASTING	LOCATION
35	11,372.7191	11,416.2280	FENCE COR
36	11,474.3157	11,294.2976	NLY FNC COR
38	11,400.0958	11,282.4051	NLY FNC COR
39	11,298.4992	11,354.3354	SLY FNC COR
40	11,411.9736	11,278.8065	BEB CONC DR
41	11,434.8784	11,297.8911	
42	11,437.2239	11,325.7070	
43	11,384.9477	11,374.4444	ANGLE PT CONC DR
44	11,364.0177	11,377.2581	ANGLE PT DR
45	11,533.1500	11,351.5380	END CONC DR
46	11,397.0000	11,281.3500	
47	11,412.8800	11,263.4900	
48	11,326.4381	11,275.2117	
49	11,439.1114	11,274.0614	

**GRADING AND PAVING PLAN**  
1" = 10'

REV	ISSUED FOR	DATE	BY

PROJECT ENGINEER:	KLA
DESIGNED BY:	TSS
DRAWN BY:	CFW
CHECKED BY:	TSS
IF THIS BAR DOES NOT MEASURE 1" THEN DRAWING IS NOT TO FULL SCALE	

30% SUBMITTAL  
DO NOT USE FOR  
CONSTRUCTION



**Hazen**  
HAZEN AND SAWYER  
7700 IRVINE CENTER DRIVE, SUITE 200  
IRVINE, CA 92618

MESA WATER DISTRICT  
COSTA MESA, CALIFORNIA  
RESERVOIR 1 & 2 PUMPS, CONTROLS, AND  
CHEMICAL SYSTEM ASSESSMENT PROJECT -  
CHEMICAL DOSING SYSTEM AND  
WATER QUALITY MONITORING

CIVIL  
RESERVOIR 2  
GRADING AND PAVING PLAN

DATE:	OCTOBER 2017
HAZEN NO.:	20035-001
CONTRACT NO.:	1
DRAWING NUMBER:	C-201

PLOT DATE: 2017/10/23 9:56:11 AM  
 FILE: C:\Users\klaus\OneDrive\Documents\2017\2017\_10\_23\_09\_56\_11.dwg  
 Scale: 1" = 10'  
 Date: 2017/10/23 11:48 AM  
 Scale: 1" = 10'  
 Date: 2017/10/23 11:48 AM



[This page is intentionally left blank.]

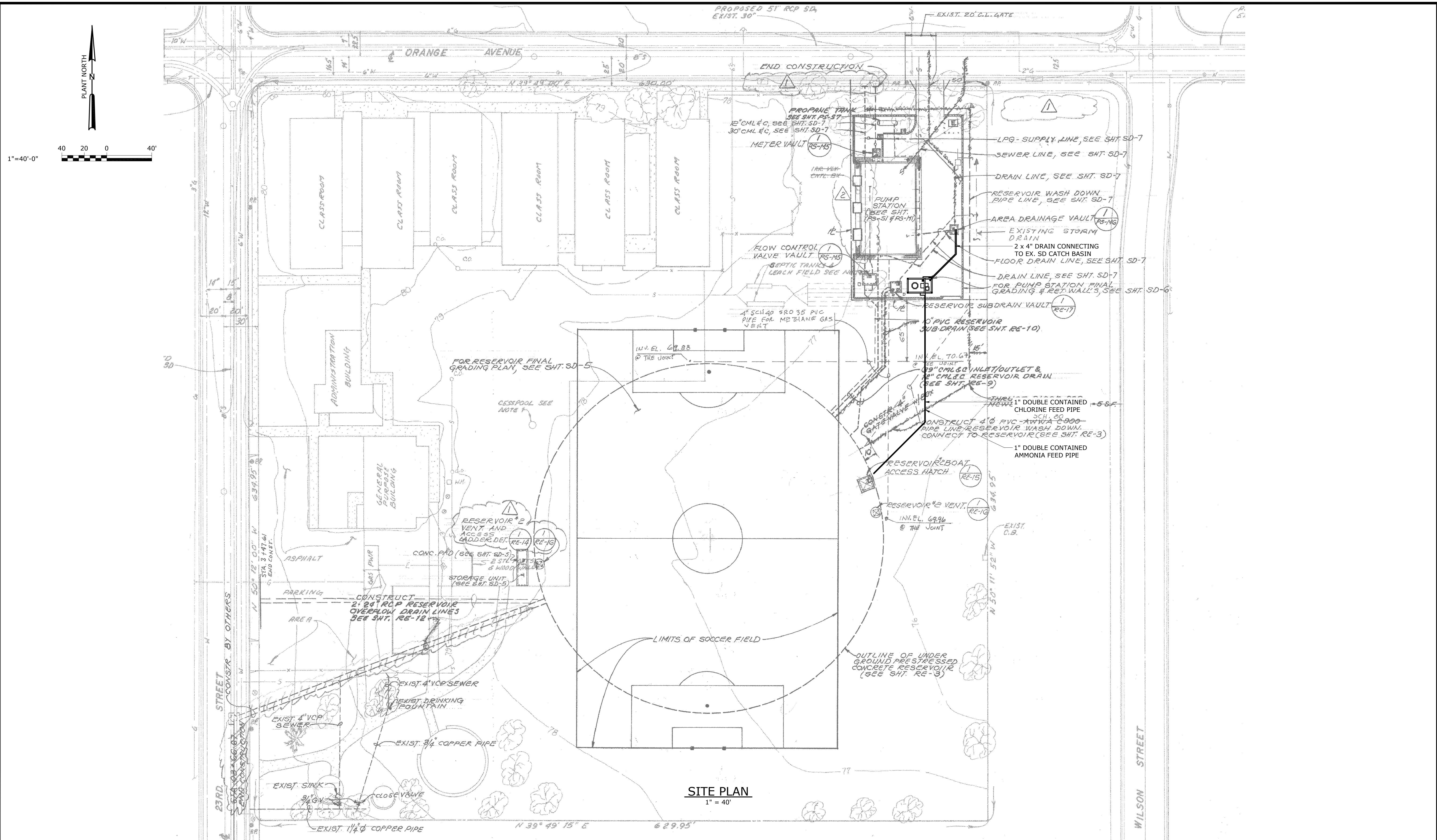

REV	ISSUED FOR	DATE	BY

PROJECT ENGINEER:	KLA
DESIGNED BY:	TSS
DRAWN BY:	CFW
CHECKED BY:	TSS
IF THIS BAR DOES NOT MEASURE 1" THEN DRAWING IS NOT TO FULL SCALE	

30% SUBMITTAL  
DO NOT USE FOR  
CONSTRUCTION

CIVIL SEAL

**Hazen**

HAZEN AND SAWYER  
7700 IRVINE CENTER DRIVE, SUITE 200  
IRVINE, CA 92618

MESA WATER DISTRICT  
COSTA MESA, CALIFORNIA

RESERVOIR 1 & 2 PUMPS, CONTROLS, AND  
CHEMICAL SYSTEM ASSESSMENT PROJECT -  
CHEMICAL DOSING SYSTEM AND  
WATER QUALITY MONITORING

CIVIL  
RESERVOIR 2  
YARD PIPING

DATE:	OCTOBER 2017
HAZEN NO.:	20035-001
CONTRACT NO.:	1
DRAWING NUMBER:	C-202

PLOT DATE: 2017/10/23 9:56:51 AM  
 PLOT BY: C:\Users\jw\Documents\2017\20035-001\CAD\CAD-202\_Sched By: CMT - Save Date: 2017/06/16 2:24 PM

[This page is intentionally left blank.]

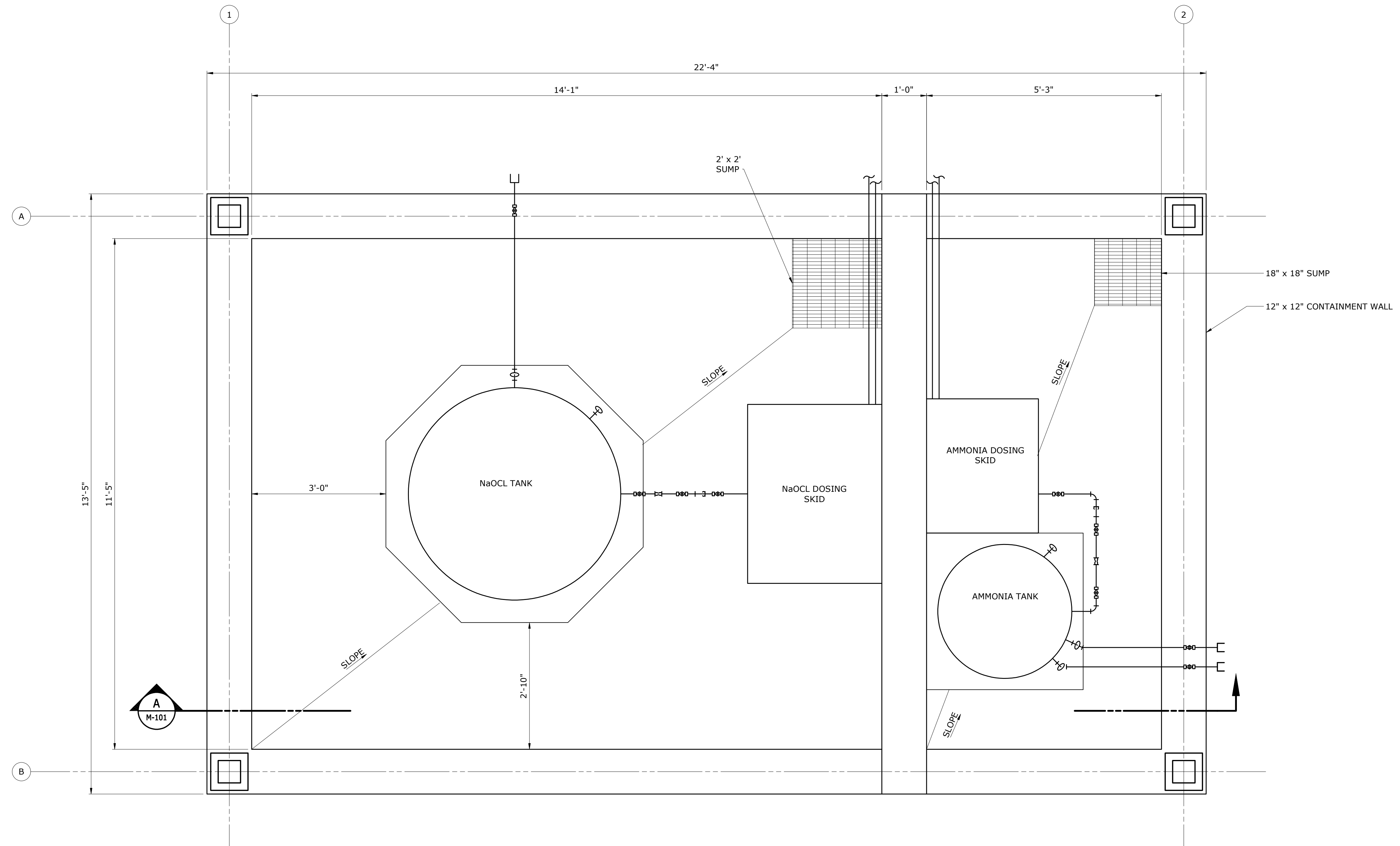

**CHEMICAL FACILITY PLAN**  
3/4" = 1'-0"

PLOT DATE: 2017/10/23 10:16:46 AM  
 FILE: C:\Users\jgarcia\OneDrive\Documents\Projects\2017\2017\_10\_23\_10\_07.dwg  
 Saved By: CMTT  
 Save Date: 2017/10/23 10:07 AM

REV	ISSUED FOR	DATE	BY

PROJECT ENGINEER:	KLA
DESIGNED BY:	TSS
DRAWN BY:	CFW
CHECKED BY:	TSS
IF THIS BAR DOES NOT MEASURE 1" THEN DRAWING IS NOT TO FULL SCALE	

30% SUBMITTAL  
DO NOT USE FOR  
CONSTRUCTION



HAZEN AND SAWYER  
7700 IRVINE CENTER DRIVE, SUITE 200  
IRVINE, CA 92618

MESA WATER DISTRICT  
COSTA MESA, CALIFORNIA

RESERVOIR 1 & 2 PUMPS, CONTROLS, AND  
CHEMICAL SYSTEM ASSESSMENT PROJECT -  
CHEMICAL DOSING SYSTEM AND  
WATER QUALITY MONITORING

MECHANICAL  
RESERVOIR 1  
CHEMICAL FACILITY PLAN

DATE:	OCTOBER 2017
HAZEN NO.:	20035-001
CONTRACT NO.:	1
DRAWING NUMBER:	M-100

[This page is intentionally left blank.]

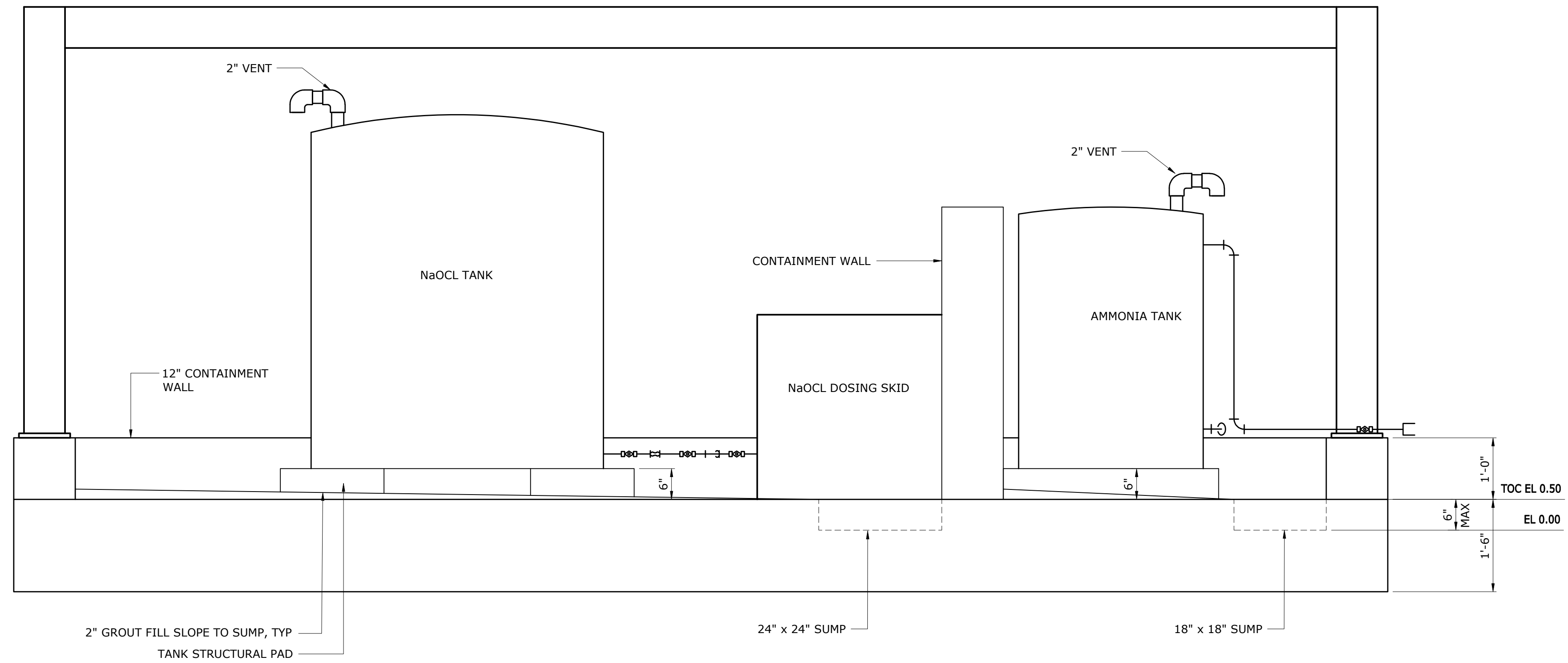

SECTION A  
3/4" = 1'-0" M-101

PLOT DATE: 2017/10/23 10:26:14 AM  
 FILE: C:\Users\jgomez\OneDrive\Documents\20035\M-101\_Schem B1.dwg  
 User: jgomez Date: 2017/09/20 1:28 PM

REV	ISSUED FOR	DATE	BY

PROJECT ENGINEER:	KLA
DESIGNED BY:	TSS
DRAWN BY:	CFW
CHECKED BY:	TSS
IF THIS BAR DOES NOT MEASURE 1" THEN DRAWING IS NOT TO FULL SCALE	

30% SUBMITTAL  
DO NOT USE FOR  
CONSTRUCTION



HAZEN AND SAWYER  
7700 IRVINE CENTER DRIVE, SUITE 200  
IRVINE, CA 92618

MESA WATER DISTRICT  
COSTA MESA, CALIFORNIA

RESERVOIR 1 & 2 PUMPS, CONTROLS, AND  
CHEMICAL SYSTEM ASSESSMENT PROJECT -  
CHEMICAL DOSING SYSTEM AND  
WATER QUALITY MONITORING

MECHANICAL  
RESERVOIR 1  
CHEMICAL FACILITY SECTION

DATE:	OCTOBER 2017
HAZEN NO.:	20035-001
CONTRACT NO.:	1
DRAWING NUMBER:	M-101

[This page is intentionally left blank.]

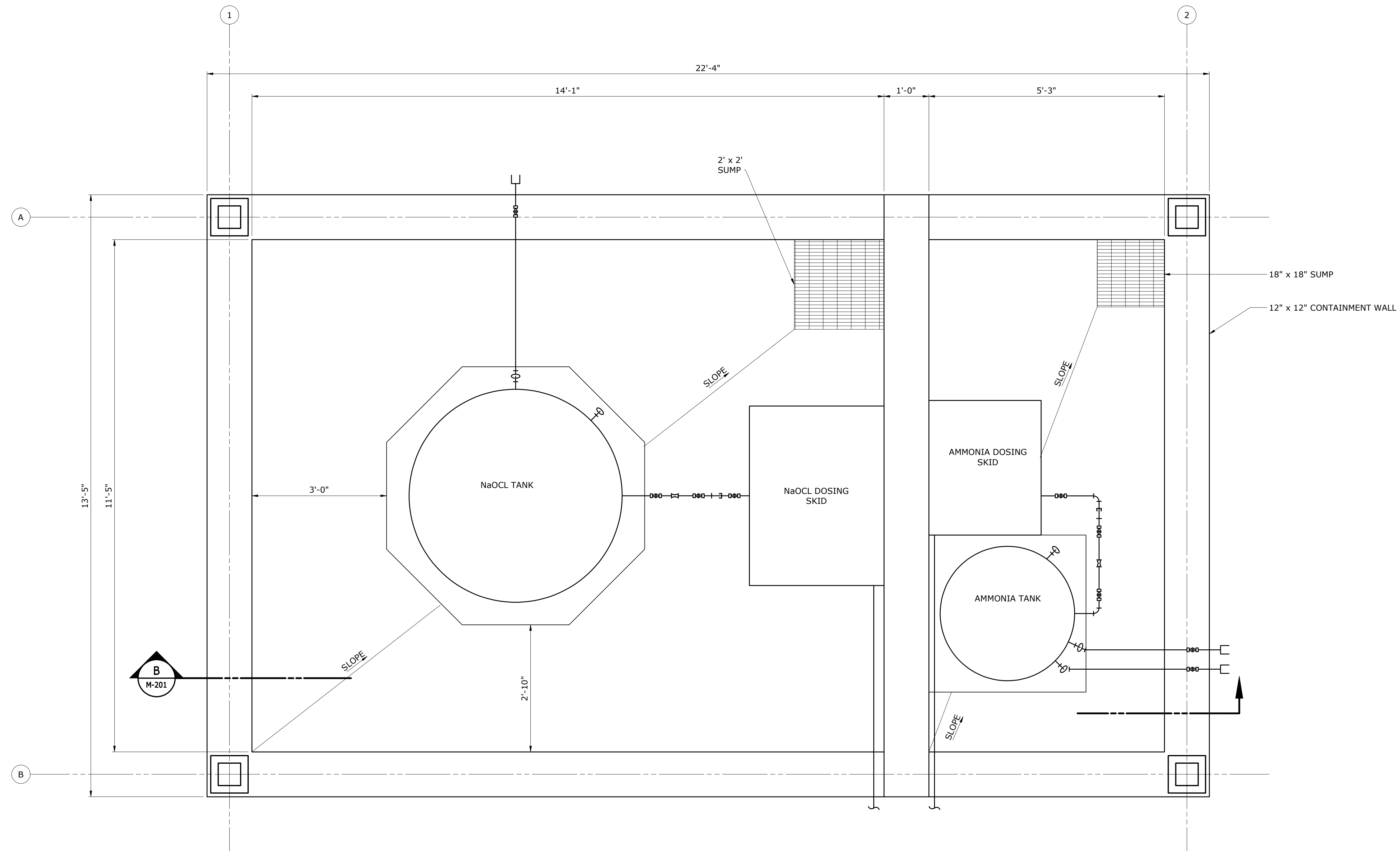

**CHEMICAL FACILITY PLAN**  
3/4" = 1'-0"

PLOT DATE: 2017/10/23 10:56:49 AM  
 FILE: C:\Users\KLA\OneDrive\Documents\20035-001\200 - Mesa Wd. CWMT - Site Date: 2017/10/23 10:18 AM

REV	ISSUED FOR	DATE	BY

PROJECT ENGINEER:	KLA
DESIGNED BY:	TSS
DRAWN BY:	CFW
CHECKED BY:	TSS
IF THIS BAR DOES NOT MEASURE 1" THEN DRAWING IS NOT TO FULL SCALE	

30% SUBMITTAL  
 DO NOT USE FOR  
 CONSTRUCTION

**Hazen**  
 HAZEN AND SAWYER  
 7700 IRVINE CENTER DRIVE, SUITE 200  
 IRVINE, CA 92618

MESA WATER DISTRICT  
 COSTA MESA, CALIFORNIA  
 RESERVOIR 1 & 2 PUMPS, CONTROLS, AND  
 CHEMICAL SYSTEM ASSESSMENT PROJECT -  
 CHEMICAL DOSING SYSTEM AND  
 WATER QUALITY MONITORING

MECHANICAL  
 RESERVOIR 2  
 CHEMICAL FACILITY PLAN

DATE:	OCTOBER 2017
HAZEN NO.:	20035-001
CONTRACT NO.:	1
DRAWING NUMBER:	M-200



[This page is intentionally left blank.]

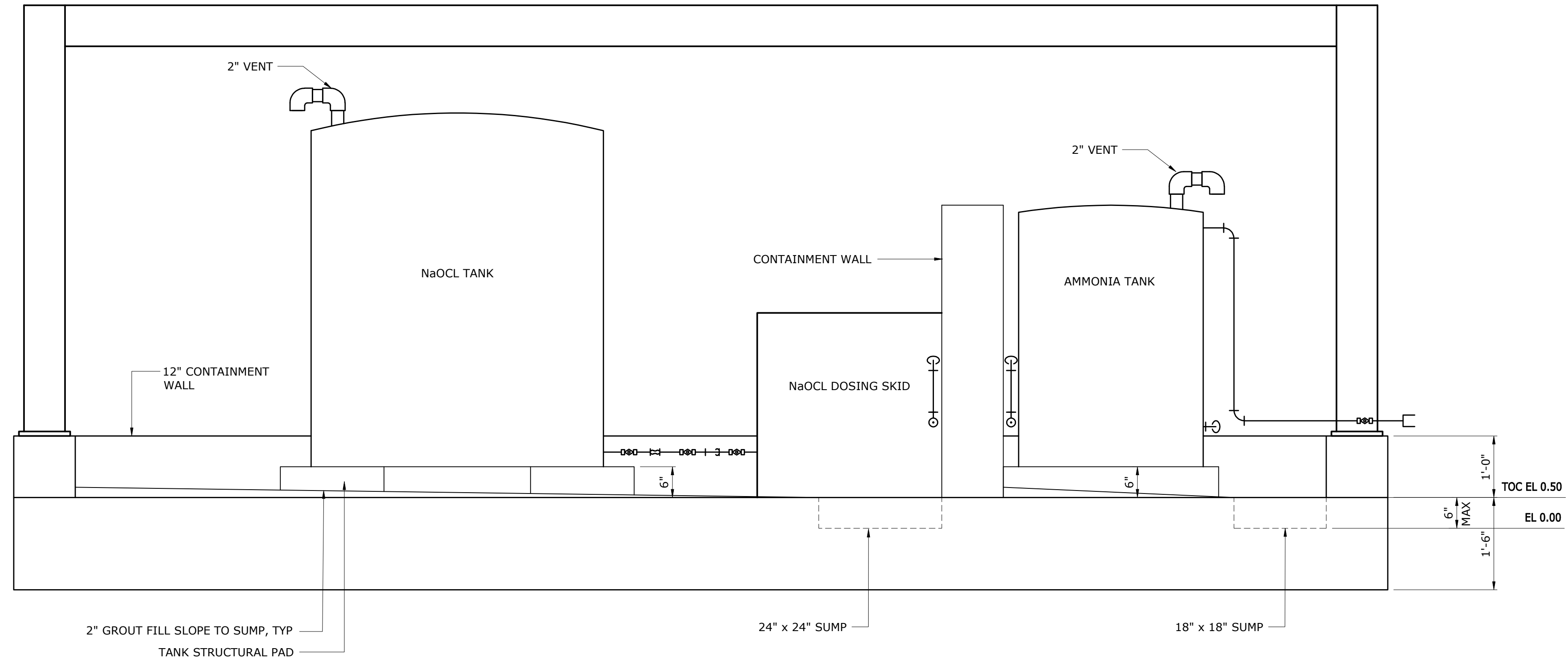

SECTION **B**  
 3/4" = 1'-0" M-200

PLOT DATE: 2017/10/23 10:25:35 AM  
 FILE: C:\Users\jgarcia\OneDrive\Documents\2017\20170620\_1150\_Plan.mxd  
 User: jgarcia Date: 2017/06/20 11:50 AM

REV	ISSUED FOR	DATE	BY

PROJECT ENGINEER:	KLA
DESIGNED BY:	TSS
DRAWN BY:	CFW
CHECKED BY:	TSS
IF THIS BAR DOES NOT MEASURE 1" THEN DRAWING IS NOT TO FULL SCALE	

30% SUBMITTAL  
 DO NOT USE FOR  
 CONSTRUCTION



HAZEN AND SAWYER  
 7700 IRVINE CENTER DRIVE, SUITE 200  
 IRVINE, CA 92618

MESA WATER DISTRICT  
 COSTA MESA, CALIFORNIA

RESERVOIR 1 & 2 PUMPS, CONTROLS, AND  
 CHEMICAL SYSTEM ASSESSMENT PROJECT -  
 CHEMICAL DOSING SYSTEM AND  
 WATER QUALITY MONITORING

MECHANICAL  
 RESERVOIR 2  
 CHEMICAL FACILITY SECTION

DATE:	OCTOBER 2017
HAZEN NO.:	20035-001
CONTRACT NO.:	1
DRAWING NUMBER:	M-201

[This page is intentionally left blank.]

## **Appendix D - Engineers Estimates of Probable Costs**

[This page is intentionally left blank.]



Summary Engineer's Estimate  
Reservoir 1 Chemical Facilities  
30 Percent Design Submittal

Date: 12/15/2017

Description	Probable Construction Cost		
	PAX Mixer	Tank Shark	Vortex Mixer
Equipment Cost	\$346,043	\$226,861	\$214,308
Construction Cost	\$629,000	\$629,000	\$629,000
<b>Subtotal</b>	<b>\$975,043</b>	<b>\$855,861</b>	<b>\$843,308</b>
Engineering and Construction Support - 15%	146,256	128,379	126,496
<b>Subtotal</b>	<b>1,121,299</b>	<b>984,240</b>	<b>969,804</b>
Contingency - 30%	336,390	295,272	290,941
<b>Total</b>	<b>1,457,689</b>	<b>1,279,512</b>	<b>1,260,745</b>



**Engineer's Estimate  
Reservoir 1 Chemical Facilities  
Probable Construction Cost  
30% Design Submittal**

Date: December 15, 2017

Item	Description		
0	General Conditions (allowed factor at this time)	20.0%	\$ 81,775
1	Chemical Storage and Dosing and Tank Mixing (Not including Equipment cost)		\$ 408,874
		<b>Subtotal:</b>	<b>\$ 490,649</b>
	Contractor Overhead	10.0%	\$ 49,065
		<b>Subtotal:</b>	<b>\$ 539,714</b>
	Contractor Profit	10.0%	\$ 53,971
		<b>Subtotal:</b>	<b>\$ 593,685</b>
	Escalation at 3% annually	2.9%	\$ 17,266
		<b>Subtotal:</b>	<b>\$ 610,951</b>
	Bond and Insurance	3.0%	\$ 18,329
		<b>Subtotal:</b>	<b>\$ 629,279</b>
	Equipment Contingency (Not including vendor proposal costs)	0.0%	\$ -
		<b>Construction Subtotal:</b>	<b>\$ 629,000</b>
	Change Order Reserves	0.0%	\$ -
		<b>Probable Construction Cost:</b>	<b>\$ 629,000</b>

**Engineer's Estimate**

Reservoir 1 Chemical Facilities

30 Percent Design Submittal - Itemized Costs

Item/Div #	Dwg#	30% Design Submittal	Quantity	Unit	Notes	Total Unit Cost	Total Cost
<b>1</b>		<b>Chemical Storage and Dosing and Tank Mixing (Not including Equipment cost)</b>					
<b>Div 02</b>		<b>Site Work</b>					
		<i>Chemical Storage and Dosing Facility</i>					
		Sawcut Pavement	130	lf		\$ 2	\$ 296
		Remove/Dispose of Pavement	820	sf		\$ 4	\$ 3,079
		Excavation	70	cy		\$ 19	\$ 1,315
		Gravel Bedding	11	cy	Assume 12-inches thick	\$ 53	\$ 590
		Backfill (Reuse)	51	cy		\$ 28	\$ 1,430
		Disposal of Soil	19	cy		\$ 31	\$ 603
		<i>Chemical Piping and Drain Piping</i>					
		Sawcut Pavement	260	lf		\$ 2	\$ 592
		Remove/Dispose of Pavement	1,050	sf		\$ 4	\$ 3,942
		Excavation	194	cy		\$ 19	\$ 3,646
		Gravel Bedding	3	cy	Assume 12-inches thick	\$ 53	\$ 171
		Backfill (Reuse)	194	cy		\$ 28	\$ 5,470
		Disposal of Soil	0	cy		\$ 31	\$ -
		Pavement Restoration	58	tn		\$ 193	\$ 11,301
		Realign Swale	1	ls		\$ 6,223	\$ 6,223
		Remove existing breaker in Distribution Panel DG	1	ea		\$ 3,165	\$ 3,165
		Remove main breaker in Panel DF	1	ea		\$ 3,165	\$ 3,165
		Remove existing Generator	1	ea		\$ 8,580	\$ 8,580
		<b>Div 02 Subtotal</b>					<b>\$ 53,567</b>
<b>Div 03</b>		<b>Concrete</b>					
		<i>Chemical Storage and Dosing Facility</i>					
		<i>Slab</i>			Including Sumps		
		Erect/Strip Formwork	150	sf		\$ 9	\$ 1,280
		Place Rebar	4,579	lb		\$ 2	\$ 7,615
		Place Concrete	22	cy		\$ 159	\$ 3,511
		Concrete Finishing	456	sf		\$ 1	\$ 557
		<i>Secondary Containment Curb</i>					
		Erect/Strip Formwork	72	sf		\$ 12	\$ 857
		Place Rebar	482	lb		\$ 2	\$ 802
		Place Concrete	3	cy		\$ 159	\$ 421
		Concrete Finishing	143	sf		\$ 1	\$ 175
		<i>Secondary Containment Wall</i>					
		Erect/Strip Formwork	134	sf		\$ 12	\$ 1,607
		Place Rebar	706	lb		\$ 2	\$ 1,174
		Place Concrete	2	cy		\$ 159	\$ 395
		Concrete Finishing	148	sf		\$ 1	\$ 180
		<i>NaOCl Tank Pad</i>					
		Erect/Strip Formwork	11	sf		\$ 9	\$ 97
		Place Rebar	147	lb		\$ 2	\$ 245
		Place Concrete	1	cy		\$ 159	\$ 95
		Concrete Finishing	43	sf		\$ 1	\$ 53
		<i>NH3 Tank Pad</i>					
		Erect/Strip Formwork	7	sf		\$ 9	\$ 60
		Place Rebar	56	lb		\$ 2	\$ 93
		Place Concrete	0.2	cy		\$ 159	\$ 36
		Concrete Finishing	19	sf		\$ 1	\$ 24
		Grout Sloped Floor	306	sf		\$ 17	\$ 5,212
		<b>Div 03 Subtotal</b>					<b>\$ 24,487</b>
<b>Div 05</b>		<b>Miscellaneous Metals</b>					
		<i>Chemical Storage and Dosing Facility Sump</i>					
		Furnish/Install Grating	6	sf		\$ 512	\$ 3,201
		<i>Chemical Storage and Dosing Facility</i>					
		Metal Columns	4	ea	8"x8" aluminum tube	\$ 2,123	\$ 8,491
		<b>Div 05 Subtotal</b>					<b>\$ 11,691</b>
<b>Div 07</b>		<b>Thermal and Moisture Protection</b>					
		<i>Chemical Storage and Dosing Facility Metal Roof</i>					
		Furnish/Install Metal Roof	300	sf		\$ 20	\$ 6,072
		<b>Div 07 Subtotal</b>					<b>\$ 6,072</b>



**Engineer's Estimate**

Reservoir 1 Chemical Facilities

30 Percent Design Submittal - Itemized Costs

Item/Div #	Dwg#	30% Design Submittal Item Description	Quantity	Unit	Notes	Total Unit Cost	Total Cost
<b>Div 09</b>		<b>Finishes</b>					
		<i>Chemical Storage and Dosing Facility</i>					
		Interior Chemical Coating	342	sf		\$ 9	\$ 3,239
		<b>Div 09 Subtotal</b>					<b>\$ 3,239</b>
<b>Div 11</b>		<b>Equipment</b>					
		<i>Tank Mixing and Chemical Storage and Dosing</i>					
		Furnish/Install tank mixer, chemical storage and dosing equipment			Added Separately	\$ -	\$ -
		<b>Div 11 Subtotal</b>					<b>\$ -</b>
<b>Div 15</b>		<b>Mechanical</b>					
		<i>Sodium Hypochlorite Pipe</i>					
		Furnish/Install NaOCl Pipe	115	lf	1-inch diameter, tubing within sch 80 CPVC	\$ 10	\$ 1,133
		Furnish/Install Fittings	2	ea		\$ 48	\$ 95
		Furnish/Install Couplings	6	ea		\$ 54	\$ 323
		Furnish/Install NaOCl Tubing	115	lf	PFA Tubing	\$ 10	\$ 1,196
		<i>Ammonia Pipe</i>					
		Furnish/Install NH3 Pipe	115	lf	1-inch diameter, tubing within sch 80 CPVC	\$ 10	\$ 1,133
		Furnish/Install Fittings	2	ea		\$ 48	\$ 95
		Furnish/Install Couplings	6	ea		\$ 54	\$ 323
		Furnish/Install NH3 Tubing	115	lf	PFA Tubing	\$ 10	\$ 1,196
		<i>Drain Pipe</i>					
		Furnish/Install Drain Pipe	122	lf	For both NaOCl and NH3, 4-inch diameter, CPVC	\$ 1	\$ 126
		Furnish/Install Fittings	2	ea		\$ 8	\$ 15
		Furnish/Install Couplings	7	ea		\$ 15	\$ 105
		Furnish/Install Manual Isolation Valve	2	ea		\$ 527	\$ 1,054
		Connection to Existing Catch Basin	2	ea		\$ 2,269	\$ 4,538
		Disinfection/Hydrostatic Testing	1	ls		\$ 3,037	\$ 3,037
		<b>Div 15 Subtotal</b>					<b>\$ 14,369</b>
<b>Div 16</b>		<b>Electrical</b>					
		<i>Chemical Storage and Dosing Facility</i>					
		Furnish/Install Power Conduit	370	lf	Assume 1.25-inch PVC	\$ 8	\$ 2,910
		Furnish/Install Power Conduit Couplings	18	ea		\$ 40	\$ 717
		Furnish/Install Power Conduit Fittings	10	ea		\$ 26	\$ 256
		Furnish/Install Power Wire	9,768	lf	Assume 24 #12	\$ 1	\$ 8,476
		Furnish/Install Control Conduit	370	lf	Assume 1.25-inch PVC	\$ 8	\$ 2,910
		Furnish/Install Control Conduit Couplings	18	ea		\$ 40	\$ 717
		Furnish/Install Control Conduit Fittings	10	ea		\$ 26	\$ 256
		Furnish/Install Control Wire	13,024	lf	Assume 32 #12	\$ 1	\$ 11,301
		<i>In-Tank Mixers</i>					
		Furnish/Install Power Conduit	710	lf	Assume 1.25-inch PVC	\$ 8	\$ 5,583
		Furnish/Install Power Conduit Couplings	35	ea		\$ 40	\$ 1,394
		Furnish/Install Power Conduit Fittings	10	ea		\$ 26	\$ 256
		Furnish/Install Power Wire	6,248	lf	Assume 8 #12	\$ 1	\$ 5,421
		Furnish/Install Control Conduit	710	lf	Assume 1.25-inch PVC	\$ 8	\$ 5,583
		Furnish/Install Control Conduit Couplings	35	ea		\$ 40	\$ 1,394
		Furnish/Install Control Conduit Fittings	10	ea		\$ 26	\$ 256
		Furnish/Install Control Wire	6,248	lf	Assume 8 #12	\$ 1	\$ 5,421
		Testing/Tagging/Terminations	5	cd		\$ 946	\$ 4,729
		Junction boxes	10	ea		\$ 896	\$ 8,957
		Furnish/Install 200kW Generator	1	ea		\$ 117,160	\$ 117,160
		Furnish/Install 350A Breaker in Distribution Panel DG	1	ea		\$ 5,083	\$ 5,083
		Furnish/Install 350A Main Breaker in Panel DF	1	ea		\$ 7,083	\$ 7,083
		<i>Between Panel DF and DG</i>					
		Furnish/Install Power Conduit	200	lf	4" PVC	\$ 20	\$ 4,089
		Furnish/Install Power Conduit Couplings	10	ea		\$ 126	\$ 1,257
		Furnish/Install Power Conduit Fittings	10	ea		\$ 140	\$ 1,397
		Furnish/Install Power Wire	660	lf	3 #500	\$ 8	\$ 5,189
		Furnish/Install Ground Wire	220	lf	#3 GND	\$ 5	\$ 1,022
		<i>Between Panel DF and Generator</i>					
		Furnish/Install Power Conduit	150	lf	4" PVC	\$ 20	\$ 3,067
		Furnish/Install Power Conduit Couplings	7	ea		\$ 126	\$ 880
		Furnish/Install Power Conduit Fittings	7	ea		\$ 140	\$ 978
		Furnish/Install Power Wire	495	lf	3 #500	\$ 8	\$ 3,892
		Furnish/Install Ground Wire	165	lf	#3 GND	\$ 5	\$ 767
		Junction Boxes	6	ea		\$ 896	\$ 5,374
		Testing/Tagging/Terminations	6	cd		\$ 946	\$ 5,675
		<b>Div 16 Subtotal</b>					<b>\$ 229,449</b>

**Engineer's Estimate**

Reservoir 1 Chemical Facilities

30 Percent Design Submittal - Itemized Costs

		<b>30% Design Submittal</b>	<b>Quantity</b>	<b>Unit</b>	<b>Notes</b>	<b>Total Unit Cost</b>	<b>Total Cost</b>
<b>Item/Div #</b>	<b>Dwg#</b>	<b>Item Description</b>					
<b>Div 17</b>		<b>Instrumentation and Control</b>					
		Integration, Programming and Testing	40	cd		\$ 1,650	\$ 66,000
		<b>Div 17 Subtotal</b>					<b>\$ 66,000</b>
		<b>Item No. 1 Subtotal</b>					<b>\$ 408,874</b>



Summary Engineer's Estimate  
Reservoir 2 Chemical Facilities  
30 Percent Design Submittal

Date: 12/15/2017

Description	Probable Construction Cost		
	PAX Mixer	Tank Shark	Vortex Mixer
Equipment Cost	\$327,949	\$261,415	\$278,264
Construction Cost	\$510,000	\$510,000	\$510,000
<b>Subtotal</b>	<b>\$837,949</b>	<b>\$771,415</b>	<b>\$788,264</b>
Engineering and Construction Support - 15%	125,692	115,712	118,240
<b>Subtotal</b>	<b>963,641</b>	<b>887,127</b>	<b>906,504</b>
Contingency - 30%	289,092	266,138	271,951
<b>Total</b>	<b>1,252,734</b>	<b>1,153,265</b>	<b>1,178,455</b>



**Engineer's Estimate  
Reservoir 2 Chemical Facilities  
Probable Construction Cost  
30% Design Submittal**

Date: December 15, 2017

Item	Description		
0	General Conditions (allowed factor at this time)	20.0%	\$ 66,259
1	Chemical Storage and Dosing and Tank Mixing (Not including Equipment cost)		\$ 331,293
		<b>Subtotal:</b>	<b>\$ 397,551</b>
	Contractor Overhead	10.0%	\$ 39,755
		<b>Subtotal:</b>	<b>\$ 437,306</b>
	Contractor Profit	10.0%	\$ 43,731
		<b>Subtotal:</b>	<b>\$ 481,037</b>
	Escalation at 3% annually	2.9%	\$ 13,990
		<b>Subtotal:</b>	<b>\$ 495,027</b>
	Bond and Insurance	3.0%	\$ 14,851
		<b>Subtotal:</b>	<b>\$ 509,878</b>
	Equipment Contingency (Not including vendor proposal costs)	0.0%	\$ -
		<b>Construction Subtotal:</b>	<b>\$ 510,000</b>
			\$ -
	Change Order Reserves	0.0%	\$ -
		<b>Probable Construction Cost:</b>	<b>\$ 510,000</b>

**Engineer's Estimate**  
**Reservoir 2 Chemical Facilities**  
**30 Percent Design Submittal - Itemized Costs**

Item/Div #	Dwg#	30% Design Submittal	Quantity	Unit	Notes	Total Unit Cost	Total Cost
<b>1</b>		<b>Chemical Storage and Dosing and Tank Mixing (Not including Equipment cost)</b>					
<b>Div 02</b>		<b>Site Work</b>					
		<i>Chemical Storage and Dosing Facility</i>					
		Sawcut Pavement	75	lf		\$ 2	\$ 171
		Remove/Dispose of Pavement	305	sf		\$ 4	\$ 1,145
		Excavation	87	cy		\$ 19	\$ 1,634
		Gravel Bedding	16	cy	Assume 12-inches thick	\$ 53	\$ 834
		Backfill (Reuse)	58	cy		\$ 28	\$ 1,617
		Disposal of Soil	30	cy		\$ 31	\$ 927
		<i>Chemical Piping and Drain Piping</i>					
		Sawcut Pavement	140	lf		\$ 2	\$ 319
		Remove/Dispose of Pavement	565	sf		\$ 4	\$ 2,121
		Excavation	105	cy		\$ 19	\$ 1,962
		Gravel Bedding	9	cy	Assume 12-inches thick	\$ 53	\$ 459
		Backfill (Reuse)	105	cy		\$ 28	\$ 2,943
		Disposal of Soil	0	cy		\$ 31	\$ -
		Pavement Restoration	27	tn		\$ 193	\$ 5,258
		Reseed Disturbed Areas	7500	sf		\$ 1	\$ 3,933
		Remove existing 70kW Generator	1	ea		\$ 8,580	\$ 8,580
		<b>Div 02 Subtotal</b>					<b>\$ 31,904</b>
<b>Div 03</b>		<b>Concrete</b>					
		<i>Chemical Storage and Dosing Facility</i>					
		<i>Slab</i>			Including Sumps		
		Erect/Strip Formwork	174	sf		\$ 9	\$ 1,485
		Place Rebar	6,040	lb		\$ 2	\$ 10,045
		Place Concrete	31	cy		\$ 159	\$ 4,974
		Concrete Finishing	604	sf		\$ 1	\$ 738
		<i>Secondary Containment Curb</i>					
		Erect/Strip Formwork	84	sf		\$ 12	\$ 1,000
		Place Rebar	563	lb		\$ 2	\$ 937
		Place Concrete	3	cy		\$ 159	\$ 492
		Concrete Finishing	167	sf		\$ 1	\$ 204
		<i>Secondary Containment Wall</i>					
		Erect/Strip Formwork	174	sf		\$ 12	\$ 2,086
		Place Rebar	1,130	lb		\$ 2	\$ 1,880
		Place Concrete	3	cy		\$ 159	\$ 513
		Concrete Finishing	192	sf		\$ 1	\$ 234
		<i>NaOCl Tank Pad</i>					
		Erect/Strip Formwork	13	sf		\$ 9	\$ 111
		Place Rebar	194	lb		\$ 2	\$ 322
		Place Concrete	1	cy		\$ 159	\$ 124
		Concrete Finishing	55	sf		\$ 1	\$ 67
		<i>NH3 Tank Pad</i>					
		Erect/Strip Formwork	9	sf		\$ 9	\$ 77
		Place Rebar	93	lb		\$ 2	\$ 155
		Place Concrete	0.4	cy		\$ 159	\$ 60
		Concrete Finishing	29	sf		\$ 1	\$ 36
		Grout Sloped Floor	430	sf		\$ 17	\$ 7,327
		<b>Div 03 Subtotal</b>					<b>\$ 32,866</b>
<b>Div 05</b>		<b>Miscellaneous Metals</b>					
		<i>Chemical Storage and Dosing Facility Sump</i>					
		Furnish/Install Grating	6	sf		\$ 512	\$ 3,201
		<i>Chemical Storage and Dosing Facility</i>					
		Metal Columns	4	ea	8"x8" aluminum tube	\$ 2,123	\$ 8,491
		<b>Div 05 Subtotal</b>					<b>\$ 11,691</b>
<b>Div 07</b>		<b>Thermal and Moisture Protection</b>					
		<i>Chemical Storage and Dosing Facility Metal Roof</i>					
		Furnish/Install Metal Roof	424	sf		\$ 20	\$ 8,589
		<b>Div 07 Subtotal</b>					<b>\$ 8,589</b>

**Engineer's Estimate**  
**Reservoir 2 Chemical Facilities**  
**30 Percent Design Submittal - Itemized Costs**

Item/Div #	Dwg#	30% Design Submittal Item Description	Quantity	Unit	Notes	Total Unit Cost	Total Cost
<b>Div 09</b>		<b>Finishes</b>					
		<i>Chemical Storage and Dosing Facility</i>					
		Interior Chemical Coating	472	sf		\$ 9	\$ 4,473
		<b>Div 09 Subtotal</b>					<b>\$ 4,473</b>
<b>Div 11</b>		<b>Equipment</b>					
		<i>Tank Mixing and Chemical Storage and Dosing</i>					
		Furnish/Install tank mixer, chemical storage and dosing equipment			Added Separately	\$ -	\$ -
		<b>Div 11 Subtotal</b>					<b>\$ -</b>
<b>Div 15</b>		<b>Mechanical</b>					
		<i>Sodium Hypochlorite Pipe</i>					
		Furnish/Install NaOCl Pipe	185	lf	1-inch diameter, tubing within sch 80 CPVC	\$ 10	\$ 1,823
		Furnish/Install Fittings	3	ea		\$ 48	\$ 143
		Furnish/Install Couplings	10	ea		\$ 54	\$ 538
		Furnish/Install NaOCl Tubing	185	lf	PFA Tubing	\$ 10	\$ 1,923
		<i>Ammonia Pipe</i>					
		Furnish/Install NH3 Pipe	225	lf	1-inch diameter, tubing within sch 80 CPVC	\$ 10	\$ 2,217
		Furnish/Install Fittings	1	ea		\$ 48	\$ 48
		Furnish/Install Couplings	12	ea		\$ 54	\$ 646
		Furnish/Install NH3 Tubing	225	lf	PFA Tubing	\$ 10	\$ 2,339
		<i>Drain Pipe</i>					
		Furnish/Install Drain Pipe	120	lf	For both NaOCl and NH3, 4-inch diameter, CPVC	\$ 32	\$ 3,795
		Furnish/Install Fittings	5	ea		\$ 134	\$ 669
		Furnish/Install Couplings	6	ea		\$ 200	\$ 1,197
		Furnish/Install Manual Isolation Valve	2	ea		\$ 527	\$ 1,054
		Connection to Existing Catch Basin	2	ea		\$ 2,269	\$ 4,538
		Disinfection/Hydrostatic Testing	1	ls		\$ 3,037	\$ 3,037
		<b>Div 15 Subtotal</b>					<b>\$ 23,968</b>
<b>Div 16</b>		<b>Electrical</b>					
		<i>Chemical Storage and Dosing Facility</i>					
		Furnish/Install Power Conduit	180	lf	Assume 1.25-inch PVC	\$ 8	\$ 1,416
		Furnish/Install Power Conduit Couplings	9	ea		\$ 40	\$ 358
		Furnish/Install Power Conduit Fittings	10	ea		\$ 26	\$ 256
		Furnish/Install Power Wire	4,752	lf	Assume 24 #12	\$ 1	\$ 4,123
		Furnish/Install Control Conduit	180	lf	Assume 1.25-inch PVC	\$ 8	\$ 1,416
		Furnish/Install Control Conduit Couplings	9	ea		\$ 40	\$ 358
		Furnish/Install Control Conduit Fittings	10	ea		\$ 26	\$ 256
		Furnish/Install Control Wire	6,336	lf	Assume 32 #12	\$ 1	\$ 5,498
		<i>In-Tank Mixers</i>					
		Furnish/Install Power Conduit	950	lf	Assume 1.25-inch PVC	\$ 8	\$ 7,471
		Furnish/Install Power Conduit Couplings	47	ea		\$ 40	\$ 1,872
		Furnish/Install Power Conduit Fittings	10	ea		\$ 26	\$ 256
		Furnish/Install Power Wire	12,540	lf	Assume 12 #12	\$ 1	\$ 10,881
		Furnish/Install Control Conduit	950	lf	Assume 1.25-inch PVC	\$ 8	\$ 7,471
		Furnish/Install Control Conduit Couplings	47	ea		\$ 40	\$ 1,872
		Furnish/Install Control Conduit Fittings	15	ea		\$ 26	\$ 384
		Furnish/Install Control Wire	12,540	lf	Assume 12 #12	\$ 1	\$ 10,881
		Testing/Tagging/Terminations	5	cd		\$ 946	\$ 4,729
		Junction boxes	10	ea		\$ 896	\$ 8,957
		Furnish/Install 70kW Generator	1	ea		\$ 42,870	\$ 42,870
		Furnish/Install 100A 3Ph, 480V Panel	1	ea		\$ 6,665	\$ 6,665
		Reconfigure ATS and new 480V Panel	1	ea		\$ 28,339	\$ 28,339
		Junctionboxes	4	ea		\$ 896	\$ 3,583
		Testing/Tagging/Terminations	2	cd		\$ 946	\$ 1,892
		<b>Div 16 Subtotal</b>					<b>\$ 151,802</b>
<b>Div 17</b>		<b>Instrumentation and Control</b>					
		Integration, Programming and Testing	40	cd		\$ 1,650	\$ 66,000
		<b>Div 17 Subtotal</b>					<b>\$ 66,000</b>
		<b>Item No. 1 Subtotal</b>					<b>\$ 331,293</b>

[This page is intentionally left blank.]

## **Appendix E - AWWA Journal Article**



[This page is intentionally left blank.]

Hypochlorite solutions contain oxyhalide species such as perchlorate, chlorate, and bromate that form during and after manufacture. Such oxyhalide species have the potential to contaminate finished drinking water if adequate control measures are not taken to minimize their formation during manufacture, shipment, and storage of hypochlorite solutions. This article describes the rate of formation of perchlorate in hypochlorite solutions and discusses the chemistry behind a series of control strategies that utilities and manufacturers can implement to minimize oxyhalide formation and introduction into drinking water. Factors affecting the formation of perchlorate include temperature, ionic strength, hypochlorite concentration, and the presence of transition metal ions. The authors conclude that with proper manufacture, storage conditions, and handling, formation of perchlorate, chlorate, and bromate can be minimized. If care is not taken during manufacture and storage of hypochlorite solutions, however, perchlorate, chlorate, and bromate levels can exceed health-based guidelines in drinking water.

## Perchlorate, bromate, and chlorate in hypochlorite solutions: Guidelines for utilities

Various forms of chlorine are commonly used in drinking water and water reuse applications for their ability to disinfect and maintain a residual level of disinfectant throughout the distribution system. The majority of utilities in the United States use chlorine gas during treatment, but approximately one third of all US drinking water treatment plants use bulk hypochlorite for disinfection, and around 8% use onsite hypochlorite generators or onsite generators (OSGs) during treatment (Routt et al, 2008a, 2008b). Hypochlorite solutions contain many regulated and unregulated contaminants, including bromate, chlorite, chlorate, and perchlorate (Asami et al, 2009; Greiner et al, 2008; Weinberg et al, 2003; Gordon et al, 1993).

The perchlorate ion (referred to here as perchlorate) has been identified as a contaminant of concern in hypochlorite solutions and drinking water and has drawn much attention because it is an endocrine-disrupting chemical that can affect the human thyroid system (Greer et al, 2002; York et al, 2001; Urbansky, 2000; Lamm et al, 1999). Furthermore, on the basis of both data

BENJAMIN D. STANFORD,

ALEKSEY N. PISARENKO,

SHANE A. SNYDER,

AND GILBERT GORDON



A full report of this project, *Hypochlorite—An Assessment of Factors That Influence the Formation of Perchlorate and Other Contaminants* (4147), is available for free to Water Research Foundation subscribers by logging on to [www.waterrf.org](http://www.waterrf.org).

from the current study and data published elsewhere, perchlorate appears to be a ubiquitous contaminant of hypochlorite solutions, and its concentration increases significantly during storage (Asami et al, 2009; Snyder et al, 2009; Greiner et al, 2008; Snyder et al, 2005).

Hypochlorite solutions also contain chlorate, which is known to increase in concentration during storage as a function of time, temperature, and a suite of chemical factors (Adam & Gordon, 1999; Gordon et al, 1995). Chlorate has been included on the third US Environmental Protection Agency (USEPA) Contaminant Candidate List and is likely to be included in the third Unregulated Contaminant Monitoring Rule, a move that sets the stage for potential future regulation. Chlorite, a regulated drinking water contaminant and a contaminant of hypochlorite solutions, tends to remain at steady state and does not exhibit the drastic changes in concentration exhibited by chlorate and perchlorate.

Finally, bromate, yet another oxyhalide contaminant of hypochlorite solutions and a potent carcinogen, results from the oxidation of bromide via a mechanism analogous to that of chlorate (Asami et al, 2009), although its concentration remains constant once the available bromide has been converted to bromate (Snyder et al, 2009). Bromate is currently regulated in drinking water at a maximum contaminant level (MCL) of 10 µg/L.

The controversy regarding potential health effects associated with perchlorate exposure via drinking water has led to significant vacillation at the federal level and limited precautionary regulation at the state level. In 2002 the USEPA published a reference dose (RfD) for perchlorate of 0.00003 mg/kg/d, which suggested a drinking water equivalent level (DWEL) of approximately 1 µg/L (Tiemann, 2008; USEPA, 2002). In 2005 the National Academy of Sciences and USEPA updated the RfD to 0.0007 mg/kg/d with a DWEL of 24.5 µg/L (USEPA, 2006), a number based on the no observable effect level (NOEL) of 0.007 mg/kg/d for inhibition of iodide uptake determined in a human clinical trial (Greer et al, 2002). However, an Aug. 19, 2009, notice in the *Federal Register* published by the USEPA (Silva, 2009) indicated a reexamination of the perchlorate regulatory determination and the potential for a national perchlorate regulation at levels as low as 1–6 µg/L. The same document defined the relative source contribution– (RSC–) adjusted health reference level (HRL) for perchlorate at 15 µg/L ( $HRL = DWEL \times RSC$ ;  $RSC = 62\%$ ). The state of Massachusetts has already set a DWEL and an MCL of 2.0 µg/L for perchlorate (MDEP, 2006), whereas California established an MCL of 6.0 µg/L (CDPH, 2007). New Jersey had proposed an MCL of 5 µg/L (NJDEP, 2009), but the state has deferred action until

after the USEPA issues a regulatory determination (Jackson, 2011; NJDEP, 2010). In addition to drinking water, perchlorate has been detected in a variety of food products and supplements (Aribi et al, 2006; Baier-Anderson et al, 2006; Snyder et al, 2006).

To complicate matters further, proposed federal legislation (i.e., the Drinking Water System Security Act of 2009, HR 3258) may impose significant burdens on the continued use of chlorine gas (which does not lead to the introduction of perchlorate) at drinking water and wastewater utilities. This development could result in a potential increase in the use of hypochlorite during treatment (which does lead to the introduction of perchlorate). Thus, utilities may be faced with a situation

in which they are required to maintain perchlorate and/or chlorate concentrations below a federal or state MCL and at the same time be under pressure to switch to hypochlorite. In other words, utilities with low levels of perchlorate in their

source water could inadvertently increase the perchlorate concentration during treatment if they switch from chlorine gas to bulk or OSG hypochlorite without taking the necessary steps to minimize perchlorate, chlorate, and bromate formation during manufacture and/or storage.

With this in mind, AWWA and the Water Research Foundation commissioned a study to investigate the factors affecting perchlorate and other oxyhalide formation in hypochlorite solutions. This project sought to understand the chemistry that could be used to predict perchlorate formation in hypochlorite solutions and to apply this information to develop a set of strategies and recommendations for utilities currently using or considering the use of bulk or OSG hypochlorite. This article discusses the implications of the chemical rate law, focusing on the guideline recommendations for utilities to minimize perchlorate formation in stored hypochlorite solutions. Although general recommendations from the research study have been discussed in *Opflow* (Stanford et al, 2009) and in the project report (Snyder et al, 2009), this article expands on each of the points and provides a more in-depth discussion. Additional data are presented regarding a comparison of bulk and OSG hypochlorite solutions obtained from participating utilities and manufacturing partners.

## MATERIALS AND METHODS

A complete discussion of all materials, analytical methods, quality assurance/quality control procedures, and experimental design is available elsewhere (Pisarenko et al, 2010; Snyder et al, 2009). Briefly, a series of experiments

---

Hypochlorite solutions contain many regulated and unregulated contaminants, including bromate, chlorite, chlorate, and perchlorate.

---

was executed during the course of this study to elucidate the mechanism of perchlorate formation and determine the factors that affect the rate of perchlorate, bromate, and chlorate formation. Because the decomposition of hypochlorite at room temperature in solutions at pH 12–13 is relatively slow—the half-life of 13% sodium hypochlorite (NaOCl) is approximately 130 days at 25°C—the bulk and OSG hypochlorite solutions ranging from 0.3–12% were incubated at controlled temperatures of 30, 40, 50, 60, and 75°C. Subsets of these solutions were spiked, diluted, and/or pH-adjusted to examine the effect of ionic strength; effect of hypochlorite, chlorite, chlorate, bromide, bromate, transition metal ion (nickel, copper, iron, manganese, and cobalt), and noble metal ion (silver, gold, platinum, palladium, and iridium) concentration; effect of pH; and relevance of the source of hypochlorite ion solutions (bulk, OSG, and calcium hypochlorite).

Throughout the course of the incubation studies, the concentration of hypochlorite, chlorate, perchlorate, bromide, and bromate, and the ionic strength of sample solutions were measured periodically (Pisarenko et al, 2010); sampling intervals were determined using predictions for hypochlorite ion decomposition rates generated by the software program Bleach 2001 (Adam et al, 2001). The incubation studies were designed to allow at least one half-life (but preferably two) of hypochlorite decomposition to occur in order to assess and quantify the rate of perchlorate ion formation. At the lowest temperature of 30°C, this resulted in incubation times of at least 130 days (half-life = 65 days at 30°C). To calculate the rates of perchlorate ion formation, the changes in measured concentration of perchlorate ion were divided by the incubation intervals. To determine the reaction order with respect to concentration of chlorate or hypochlorite ion, the natural log of the rate of perchlorate ion formation (measured experimentally) was plotted versus the natural log of each ion at various concentrations in solutions at constant chlorate or hypochlorite ion concentrations.

A detailed discussion of the steps for determining the reaction kinetics and the predictive model is included in the project report (Snyder et al, 2009).

In addition to the incubation studies for elucidation of reaction mechanism and kinetics, an occurrence survey was conducted. Hypochlorite samples as well as samples of raw, finished, and distribution system water were collected from seven participating utilities. Of these utilities, five used bulk hypochlorite, two used OSG hypochlorite, and one used chlorine gas. One participating utility (utility 7) was a wastewater treatment plant that used bulk hypochlorite for disinfection of water for nonpotable reuse. Utility 7 represented the only wastewater plant in the study and was chosen as a challenge water to determine whether the more complex matrix could affect perchlorate formation in a simulated distribution system (SDS) study. Table 1 summarizes the relevant utility descriptions.

In addition to the utilities that participated in this study, two large suppliers of OSG systems agreed to supply hypochlorite solutions from 10 additional OSG locations and/or systems, providing a total of 12 OSG hypochlorite samples, including the two from the participating utilities. Table 2 provides a description of the OSG systems; OSG 9 and 10 are cross-referenced with those in Table 1. All OSGs tested used an electrolytic conversion of a salt brine solution to hypochlorite.

Finally, one supplier of calcium hypochlorite provided freshly manufactured calcium hypochlorite in solid form. Although formation of perchlorate in a solid sample is likely to be limited, calcium hypochlorite was investigated to determine whether perchlorate was present from the manufacturing process.

## RESULTS AND DISCUSSION

**Chemical rate law.** A detailed discussion of the kinetics behind the chemical rate law for perchlorate formation is beyond the scope of this article and is available elsewhere (Snyder et al, 2009). Because the implications of

**TABLE 1** Information on utilities sampled, age of hypochlorite, and water source

Utility	Hypochlorite Source	Sampling Date	Hypochlorite Age	Water Source
1A	Bulk	01/21/2009	60%—90 days, 40%—7 days	SW
1B	OSG 9	01/21/2009	2 days since production	SW
2	Bulk	01/26/2009	34 days	SW
3	Cl <sub>2</sub> gas	01/20/2009	NA	GW, RBF
4	Bulk	01/26/2009	≥ 5 days	GW
5	OSG 10	01/29/2009	< 1 day	SW
6	Bulk	02/07/2009	≥ 12 days	OD, SW, GW
7	Bulk	01/27/2009	1–6 days	WW

Cl<sub>2</sub>—chlorine, GW—groundwater, NA—not applicable, OD—ocean desalination, OSG—onsite generator, RBF—riverbank filtration, SW—surface water, WW—tertiary treated wastewater for nonpotable reuse

perchlorate formation kinetics are integral to the research discussed in this article, however, a brief summary of the rate law is included.

Hypochlorite ( $\text{OCl}^-$ ) is unstable and undergoes two independent modes of self-decomposition in solution (Gordon et al, 1995; Adam, 1994). In one mode, oxygen ( $\text{O}_2$ ) and chloride ( $\text{Cl}^-$ ) are formed, whereas in the other mode, chlorate ( $\text{ClO}_3^-$ ) and  $\text{Cl}^-$  are formed:



The rate of decomposition of hypochlorite to form chlorate and/or oxygen is well defined in terms of the following rate law:

$$\frac{d[\text{OCl}^-]}{3dt} = k_{\text{observed}} [\text{OCl}^-]^2 \quad (3)$$

Chlorite ( $\text{ClO}_2^-$ ) is rapidly formed as a steady-state species (equation not shown) and serves as an intermediate between hypochlorite and chlorate ions. Results from this study indicated that perchlorate ( $\text{ClO}_4^-$ ) is formed when hypochlorite and chlorate ions further react (Eq 4), thereby forming the basis of the rate law described in Eq 5:

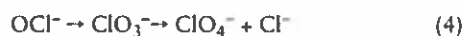

$$\frac{d[\text{ClO}_4^-]}{dt} = k_{\text{calculated}} [\text{OCl}^-] [\text{ClO}_3^-] \quad (5)$$

What appears to be a simple rate law, however, is not trivial to deconvolute and quantify in a detailed chemical rate law. In considering the kinetics of perchlorate formation, it must be understood that the concentration of one reactant (hypochlorite) is decreasing via two possible pathways, whereas the concentration of the second reactant (chlorate) is increasing as a function of the concentration of the first reactant. To complicate matters further, a portion of the chlorate being produced is also being consumed in the production of perchlorate. Thus, the observed increase of chlorate is in reality a combined function of chlorate production and chlorate oxidation to perchlorate. Additionally, the rate of perchlorate formation is dependent on factors other than hypochlorite and chlorate concentrations including ionic strength and temperature.

Another factor that directly affects the rate of perchlorate formation is pH, although this effect is limited because most hypochlorite solutions are stored in the range of pH 11–13. Above pH 13, ionic strength effects dominate (Adam & Gordon, 1999), whereas below pH 10.5 a separate, faster hypochlorite decomposition pathway dominates. However, if the model is bound within the typical pH range of hypochlorite (pH 11–13), the effects of pH can be disregarded. Indirect factors influencing the rate of perchlorate formation include the presence of transition metal ions and the presence of bromide ions, both of which consume hypochlorite ions through catalytic decomposition (transition metal ions) or formation of hypobromite and bromate ions.

With these considerations in mind, a detailed chemical rate law was developed and validated using bulk hypochlorite solutions. Quantitative chemical rate law incor-

**TABLE 2** Description of OSGs, identification numbers, and salt source

OSG Model	Anode Material*	OSG Capacity lb/d	OSG Energy kW-h/lb FAC	Years of Service	Salt Source
1A	DSA	24	2.0	4	Unknown
1B	DSA	2,000	2.0	10	Unknown
2A	DSA	75	2.0	4	Unknown
2B	DSA	450	2.0	3	Unknown
3	DSA	750	2.0	1	Unknown
4	DSA	300	2.0	2	Unknown
5	DSA	400	2.0	†	> 99.7% as NaCl
6	DSA	180	3.5	†	> 99.7% as NaCl
7	DSA	20	3.3	†	> 99.5% as NaCl
8	DSA	10	5.2	†	> 99.5% as NaCl
9	DSA	1,200	Unknown	3	> 96% as NaCl
10	DSA	2,000	1.6–2.0	2.5, 6.5	> 99.7% as NaCl

DSA—dimensionally stabilized anode, FAC—free available chlorine, NaCl—sodium chloride, OSG—onsite generator

\*Material likely was titanium.

†Because OSG units were used only at the factory for testing, service time was much less than one year.

porates ionic strength and temperature effects in the calculated rate constant (Eq 6), which can be incorporated into Eq 5 to determine the stepwise rate of perchlorate formation (and change in concentration) as hypochlorite and chlorate concentrations change as predicted by Bleach 2001 (Adam et al, 2001). In Eq 6,  $I$  represents the ionic strength of solution,  $R$  represents the ideal gas constant, and  $T$  represents temperature (in kelvin). Eq 6 is dimensionally correct because the  $2.084 \times 10^{10}$  term is the result of dividing Boltzmann's constant ( $k$ ) by Planck's constant, resulting in units of  $k^{-1}s^{-1}$ , thereby canceling with the temperature term and leading to a per-second rate term.

$$\log(k_{\text{calculated}}) = 0.0788(I) + \log(2.084 \times 10^{10} \times T \times e^{-1.01 \times 10^5/RT} \times e^{-10^6/R}) \quad (6)$$

Eqs 5 and 6 were validated by using them to calculate the rate of perchlorate formation at different temperatures for bulk hypochlorite samples that varied in concentration and ionic strength. Figure 1 shows the measured perchlorate concentrations from experimental data and calculated perchlorate concentrations from Eqs 5 and 6. The calculated concentrations were fitted to a smooth line, and fixed 10% error bars were added. The data shown in Figure 1 indicate agreement of better than 10% between measured perchlorate concentration and calculated perchlorate concentration in most cases during the entire period of the holding studies. The agreement between experimental and calculated perchlorate concentrations supports the conclu-

sion that the formation of perchlorate is a second-order reaction (first-order each in hypochlorite and chlorate) that is highly dependent on ionic strength and temperature. Thus, Eqs 5 and 6 can be used in conjunction with Bleach 2001 to accurately predict perchlorate concentrations as a function of time.

#### Survey of bulk, OSG, and calcium hypochlorite solutions.

The concentration of hypochlorite, perchlorate, chlorate, and bromate in the bulk samples for each of the seven utilities is shown in Table 3. Several observations can be drawn from these data.

- Only at utility 1A did perchlorate levels in the bulk hypochlorite appear to have a significant effect on the finished water concentration. Utility A's low free available chlorine (FAC) concentration (compared with other bulk hypochlorite solutions tested) and the high levels of perchlorate and chlorate could be explained by the age of the hypochlorite solution, which was a mixture of 90-day-old (60%) and 7-day-old (40%) bulk hypochlorite.

- None of the utility results were above California's 6- $\mu\text{g/L}$  MCL for perchlorate, and only two were above Massachusetts's 2- $\mu\text{g/L}$  MCL.

- Chlorate contamination from the hypochlorite solutions appeared to affect all of the utilities tested. As shown in Table 3, of the utilities tested, four had concentrations of chlorate in the finished drinking water above the 200- $\mu\text{g/L}$  (0.2-mg/L) proposed action level in California, and at one of these, the chlorate concentration was nearly twice the 800- $\mu\text{g/L}$  (0.8-mg/L) notification level recommended by the state (Howd, 2002).

**FIGURE 1** Measured and calculated decomposition of hypochlorite and formation of chlorate by software program (A) and perchlorate concentration predicted by Eqs 5 and 6 (B) at 30°C

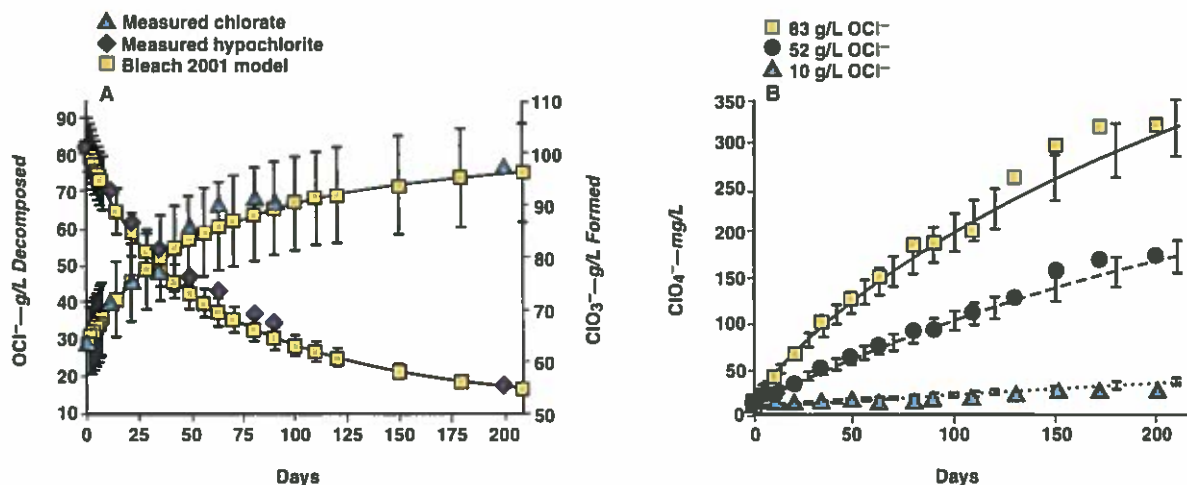

ClO<sub>3</sub><sup>-</sup>—chlorate, ClO<sub>4</sub><sup>-</sup>—perchlorate, OCI<sup>-</sup>—hypochlorite

Solid lines indicate calculated concentration with  $\pm 10\%$  error bars. Software program used was Bleach 2001 (Adam et al, 2001).

• Bromate was observed at milligram-per-litre levels in all bulk hypochlorite solutions, although none of the utilities tested had finished water concentrations above the 10- $\mu\text{g/L}$  bromate MCL mandated by the USEPA.

As shown in Table 4, the OSG hypochlorite samples also exhibited high variations in FAC, chlorate, and perchlorate concentrations. Eight OSG samples had < 700 mg/L of chlorate in the resulting hypochlorite solution. Bromate concentration ranged from 0.2 to 6 mg/L. Bromate concentrations are limited by the available bromide (which is rapidly converted to bromate in concentrated hypochlorite solutions) and is likely related to the amount of bromide present in the salt and/or feedwater used for hypochlorite generation. However, no discernable trends were found in the amount of perchlorate or chlorate formed by any given OSG with respect to energy consumption, OSG production capacity (pounds per day), or actual FAC concentrations. The solution for OSG 9 had the highest perchlorate concentration but was at least 48 h old when collected and may have been stored at temperatures up to 42°C. The brine solution and feedwater for OSG 9 were also at 40–42°C before electrolytic conversion.

Transition metal ion concentrations measured for this study were below detection in most of the bulk hypochlorite and OSG samples (data not shown), although utility 1A had nickel present at 0.2 mg/L, cop-

per at 0.1 mg/L, and iron concentrations approaching 10 mg/L in the hypochlorite solution. Given that metal ions have been demonstrated to have a catalytic effect on the decomposition of hypochlorite (Adam, 1994; Gordon et al, 1993), the presence of iron and nickel may have been a factor (in addition to age) in the low FAC concentration at utility 1A. Regarding the OSG hypochlorite, most brine samples showed higher levels of metal ion contamination relative to the hypochlorite product from the OSG (data not shown). This difference is likely attributable to loss of metal ions to reduction

and/or plating on the anode of the electrolytic cell. Current hypochlorite specifications recommend < 0.1 mg/L iron and < 0.05 mg/L nickel, copper, and cobalt (Gordon & Bubnis, 2000). The bulk hypochlorite sampled from utilities 1A,

The observed increase of chlorate is in reality a combined function of chlorate production and chlorate oxidation to perchlorate.

4, 6, and 7 all contained at least one transition metal above the specified levels.

Transition metal ions were not measured in the calcium hypochlorite solutions. However, bromate, chlorate, and perchlorate all were measured for the 3 and 6% (as FAC) solutions of calcium hypochlorite immediately after mixing with reagent water. The 3% calcium hypochlorite solution had 390 mg/L chlorate, 27  $\mu\text{g/L}$  perchlorate, and 2.4 mg/L bromate for 32 g/L FAC. The 6% calcium hypochlorite solution had 830 mg/L chlorate, 55  $\mu\text{g/L}$  perchlorate, and 5.3 mg/L bromate for 61 g/L FAC.

**TABLE 3** Summary of perchlorate, chlorate, and bromate concentrations in raw water, finished water, and hypochlorite used at participating utility locations

Utility	Source	FAC g/L	$\text{ClO}_4^-$			$\text{ClO}_3^-$			$\text{BrO}_3^-$		
			Hypo $\mu\text{g/L}$	Raw $\mu\text{g/L}$	Finished $\mu\text{g/L}$	Hypo mg/L	Raw mg/L	Finished mg/L	Hypo $\mu\text{g/L}$	Raw $\mu\text{g/L}$	Finished $\mu\text{g/L}$
1A	Bulk	87	14,000	< 0.5	3.6	19,000	0.014	0.58	24,000	< 0.5	0.5
1B	OSG 9	6.8	3,500	< 0.5	< 0.5	760	0.026	1.5	5,700	< 0.5	3.6
2	Bulk	150	670	< 0.5	< 0.5	5,900	0.005	0.019	30,000	< 0.5	< 0.5
3	$\text{Cl}_2$ gas	NA	NA	< 0.5	< 0.5	NA	< 0.003	< 0.003	NA	< 0.5	< 0.5
4	Bulk	120	220	< 0.5	< 0.5	1,800	0.13	0.20	9,000	1.3	1.4
5	OSG 10	8.7	19	2.0	2.1	780	0.008	0.16	150	< 0.5	1.3
6	Bulk	120	230	< 0.5	< 0.5	2,400	< 0.003	0.13	9,900	< 0.5	0.92
7	Bulk	130	2,000	1.6	1.2	8,000	< 0.003	0.79	7,700	< 0.5	2.6

$\text{BrO}_3^-$ —bromate,  $\text{Cl}_2$ —chlorine,  $\text{ClO}_3^-$ —chlorate,  $\text{ClO}_4^-$ —perchlorate, FAC—free available chlorine, NA—not applicable, OSG—onsite generator

"Hypo" indicates hypochlorite solution. "Raw" indicates raw water entering the treatment plant. "Finished" indicates finished water leaving the treatment plant. Samples were analyzed in duplicate measurements, with average percent difference for  $\text{ClO}_4^-$  = 2.0%,  $\text{BrO}_3^-$  = 4.2%, and  $\text{ClO}_3^-$  = 2.5%.

In light of the data described previously, a comparison was made by normalizing all of the contaminant concentrations to the concentration of FAC. Table 5 was created to show a relative contribution (on a basis of mass of contaminant per milligram of FAC) from each hypochlorite solution. Of the comparisons made within the limited data set collected for this project, the only trend that stood out was that the OSG hypochlorite samples consistently contributed more bromate per milligram of FAC than the fresh bulk hypochlorite solutions or the two calcium hypochlorite solutions tested. The higher levels of bromate in the OSG solutions likely were a result of bromide in the feedwater and/or salt used to make the brine solutions for electrolysis. Current NSF/ANSI 60 standards recommend no more than 0.5  $\mu\text{g BrO}_3^-$  /mg FAC (NSF/ANSI, 2005) in hypochlorite solutions. On the basis of this limit, three OSG solutions exceeded the recommendation and an additional two OSGs approached the limit (0.48  $\mu\text{g BrO}_3^-$  per mg FAC). Neither the calcium hypochlorite sample nor any of the bulk hypochlorite solutions exceeded the current bromate standard. Furthermore, only OSG 5–8 and OSG 10 used a salt with > 99.5% purity as sodium chloride (NaCl), a fact reflected in the lowest overall bromate concentrations. Thus, these data support the use of high-quality, low-bromide salts for hypochlorite generation, although further investigations quantifying purity and maximum bromide levels in salts used for OSG solutions should be performed.

Other than the relationship between salt quality and bromate formation, no consistent trends were observed. Contaminant oxyhalide concentration varied widely within and between brands, hypochlorite sources, and

production methods; this study showed no clear advantage of one over another with respect to chlorate and perchlorate concentration. Therefore, on the basis of this data set, there appears to be no straightforward way to determine what type of freshly prepared hypochlorite solution (OSG, bulk, or calcium) would result in the lowest mass loading of contaminants into the finished drinking water, an observation consistent with OSG and bulk hypochlorite data reported elsewhere (Asami et al, 2009). In light of potential perchlorate and/or chlorate regulation by federal or state agencies, investigations into methods used to minimize chlorate and perchlorate formation during OSG and bulk manufacturing processes should be of utmost importance.

**Contaminant concentrations in distribution system and SDS samples.** Perchlorate, chlorate, and bromate concentrations were also measured in the distribution system samples in order to determine whether any additional chlorate, perchlorate, or bromate had been formed. In the case of utility 2, an SDS study was used instead of collecting actual distribution system samples. Distribution system sampling locations were targeted to provide median and maximum residence times for each utility. Based on the developed model and considerations of hypochlorite concentration, temperature, pH, and ionic strength, it was not expected that any appreciable formation of chlorate, perchlorate, or bromate would be observed. Table 6 shows the results of the distribution system sampling and one SDS study.

In all cases except utility 1B, no meaningful increase in the concentration of perchlorate was observed in the distribution system. Although some chlorate data points for the distribution system were higher than in the fin-

**TABLE 4** Chlorate, bromate, and perchlorate concentration for OSG hypochlorite and brine

OSG Model	OSG Hypochlorite				Brine		
	$\text{ClO}_3^-$ mg/L	$\text{BrO}_3^-$ mg/L	$\text{ClO}_4^-$ $\mu\text{g/L}$	FAC g/L	$\text{ClO}_3^-$ mg/L	$\text{BrO}_3^-$ mg/L	$\text{ClO}_4^-$ $\mu\text{g/L}$
1A	140	4.1	5.4	9.7	<0.5	<0.1	<2.5
1B	240	3.8	16	8.0	<0.5	<0.1	<2.5
2A	97	5.3	8.6	6.8	<0.5	<0.1	<2.5
2B	360	3.3	410	6.9	<0.5	<0.1	<2.5
3	270	4.4	7.3	10	<0.5	<0.1	<2.5
4	1,200	2.6	40	4.5	<0.5	<0.1	<2.5
5	260	2.6	31	8.0	<0.5	<0.1	<2.5
6	180	1.4	22	5.2	<0.5	<0.1	<2.5
7	750	2.0	83	7.2	2.0	<0.1	<2.5
8	240	0.71	740	3.6	2.1	<0.1	<2.5
9	760	5.7	3,500	6.8	7.2	<0.1	65
10	780	0.15	19	8.7	<0.5	<0.1	<2.5

$\text{BrO}_3^-$ —bromate,  $\text{ClO}_3^-$ —chlorate,  $\text{ClO}_4^-$ —perchlorate, FAC—free available chlorine, OSG—onsite generator



ished water, the authors believe that this was related to the difference in hypochlorite age and dose at the time of treatment rather than a mechanistic formation of chlorate in dilute solutions (i.e., chlorinated water) in the distribution system.

The difficulty with using grab samples from a distribution system is that the hypochlorite solution used to disinfect the water is constantly changing and experiences turnover from new shipments and/or onsite generation. Therefore, in order to fully assess the behavior of chlorate, perchlorate, and bromate in distribution systems, an in-depth study with more sampling sites (and distribution systems) combined with temporal observations for a period of several months is suggested as a future research direction. However, because conditions in distribution systems

(i.e., low hypochlorite concentration, low ionic strength) are expected to be unfavorable for perchlorate formation, additional significant perchlorate formation is not anticipated.

**Implications of utility sampling and the detailed chemical rate law.** Information gathered in this study combined with the utility and OSG hypochlorite surveys provided the data and tools necessary to make qualitative and quantitative recommendations to utilities that can be used to minimize the introduction of perchlorate and bromate into finished waters. These data also helped to elucidate the factors influencing the formation of perchlorate in stored hypochlorite solutions.

The authors examined how factors such as dilution and temperature might affect the relative rate of per-

Proper management of stored hypochlorite solutions can have significant benefits in addressing for potential perchlorate compliance issues.

**TABLE 5** Relative contribution of specific contaminants on per-mass-FAC basis

Identification	Concentration in Hypochlorite Solutions				Mass of Contaminant Added per Milligram FAC		
	ClO <sub>3</sub> <sup>-</sup> mg/L	BrO <sub>3</sub> <sup>-</sup> mg/L	ClO <sub>4</sub> <sup>-</sup> µg/L	FAC g/L	ClO <sub>3</sub> <sup>-</sup> µg/mg FAC	BrO <sub>3</sub> <sup>-</sup> µg/mg FAC	ClO <sub>4</sub> <sup>-</sup> ng/mg FAC
Bulk/Utility							
1A	19,000	24	14,000	87	220	0.28	160
2	5,900	30	670	150	39	0.20	4.5
3	NA	NA	NA	NA	NA	NA	NA
4	1,800	9	220	120	15	0.08	1.8
6	2,400	10	230	120	20	0.08	1.9
7	8,000	8	2,000	130	62	0.06	15
OSG							
1A	140	4.1	5.4	9.7	14	0.42	0.6
1B	240	3.8	16	8	30	0.48	2.0
2A	97	5.3	8.6	6.8	14	0.78	1.3
2B	360	3.3	410	6.9	52	0.48	59
3	270	4.4	7.3	10	27	0.44	0.7
4	1,200	2.6	40	4.5	270	0.58	8.9
5	260	2.6	31	8	33	0.33	3.9
6	180	1.4	22	5.2	35	0.27	4.2
7	750	2	83	7.2	100	0.28	12
8	240	0.71	740	3.6	67	0.20	210
9	760	5.7	3,500	6.8	110	0.84	520
10	780	0.15	19	8.7	90	0.02	2.2
Ca(OCl) <sub>2</sub>							
1	390	2.4	27	32	12	0.08	0.8
2	830	5.3	55	61	14	0.09	0.9

BrO<sub>3</sub><sup>-</sup>—bromate, Ca(OCl)<sub>2</sub>—calcium hypochlorite, ClO<sub>3</sub><sup>-</sup>—chlorate, ClO<sub>4</sub><sup>-</sup>—perchlorate, FAC—free available chlorine, NA—not applicable, OSG—onsite generator

chlorate formation in a hypothetical bulk hypochlorite solution with a starting concentration of 2 M OCl<sup>-</sup> or approximately 13% FAC. Figure 2 shows results at 25 and 35°C. Results demonstrated the inverse relationship between hypochlorite concentration and perchlorate concentration (Figure 2, parts A and B) and showed that the mass of perchlorate added on a per-mg FAC basis increased much more rapidly than the concentration of perchlorate alone (Figure 2, parts C and D). In other words, as the hypochlorite solution ages, the concentration of hypochlorite decreases (Figure 2, parts A and B), forcing an operator to feed a higher volume of hypochlorite solution in order to achieve the target chlorine dose during treatment. Because the aged hypochlorite solution contains a greater concentration of perchlorate compared with the fresh solution (Figure 2, parts A and B), the operator would be dosing a higher volume of a solution with an elevated perchlorate concentration.

A secondary interpretation of the results shown in Figure 2 would be the ability to predict the number of days a hypochlorite solution can be stored before exceeding a given perchlorate concentration threshold. For example, storage of the hypothetical undiluted hypochlorite solution for approximately one month would result in a perchlorate concentration of approximately 0.5 µg ClO<sub>4</sub><sup>-</sup>/mg FAC. If that same utility was using a total of 6 mg/L FAC during the entire treatment process, there would be a cor-

responding loading of 3 µg/L of perchlorate above the background concentration. Thus, at the Massachusetts MCL of 2 µg/L, the utility would be out of compliance. Had the same utility diluted the solution at a 1:2 ratio, however, the corresponding perchlorate concentration would be only 0.05 µg/L, corresponding to a loading of

0.3 µg/L of perchlorate above the background (assuming the same 6-mg/L FAC dose). Clearly, proper management of stored hypochlorite solutions can have significant benefits in addressing perchlorate compliance issues.

The calculations from Eqs 5 and 6 were used to develop Table 7, which provides a list of reduction factors, or the relative decrease in the rate of perchlorate

formation for different dilution and temperature scenarios (e.g., by diluting by half and cooling the solution by 10°C, the rate of perchlorate formation would be 27 times slower than if the solution was stored undiluted at ambient temperature). The combination of Figure 2 and Table 7 should provide utilities with an applied version of the model to assist them with identifying control strategies that can be implemented in order to better control hypochlorite decomposition and perchlorate formation.

## RECOMMENDATIONS

The findings presented led to the identification of several key factors that influence the formation of perchlorate, chlorate, and bromate in hypochlorite solu-

Careful control of the quality of hypochlorite used in drinking water treatment could be equally, if not more, important for utilities operating near or above any potential federal or state maximum contaminant level resulting from source water contamination.

**TABLE 6** Perchlorate, chlorate, and bromate concentrations in finished waters and distribution system samples

Utility	Residence Time A h	Residence Time B h	ClO <sub>4</sub> <sup>-</sup>			ClO <sub>3</sub> <sup>-</sup>			BrO <sub>3</sub> <sup>-</sup>		
			Finished µg/L	Distribution A µg/L	Distribution B µg/L	Finished mg/L	Distribution A mg/L	Distribution B mg/L	Finished µg/L	Distribution A µg/L	Distribution B µg/L
1A	36	72	3.6	<0.5	3.1	0.58	0.59	1.2	0.5	0.80	2.9
1B	36	72	<0.5	3.2	3.1	1.5	1.4	1.3	3.6	3.4	2.8
2	72	216	<0.5	<0.5	<0.5	0.019	0.046	0.045	<0.5	<0.5	<0.5
3	96	168	<0.5	<0.5	<0.5	<0.003	<0.003	<0.003	<0.5	<0.5	<0.5
4	36	72	<0.5	<0.5	<0.5	0.20	<0.003	<0.003	1.4	2.1	2.2
5	6	12	2.1	2.2	2.2	0.16	0.14	0.031	1.3	2.6	2.2
6	12	24	<0.5	<0.5	<0.5	0.13	0.13	0.13	0.92	0.80	0.90
7*	100	150	1.2	1.2	0.90	0.79	1.6	0.82	2.6	5.9	3.2

BrO<sub>3</sub><sup>-</sup>—bromate, ClO<sub>3</sub><sup>-</sup>—chlorate, ClO<sub>4</sub><sup>-</sup>—perchlorate, SDS—simulated distribution study

\*SDS was conducted on wastewater samples instead of collecting actual distribution system samples. Sample A had free chlorine residual with no ammonia, whereas sample B had excess ammonia present, and thus free chlorine was converted entirely to chloramines.

tions. The major factors affecting perchlorate formation parallel those previously described for reducing the decomposition of bleach: temperature, ionic strength, concentration, and pH (Gordon & Bubnis, 2000; Gordon et al, 1997; Gordon et al, 1993). The information gathered during this study provided the basis for several hypothetical hypochlorite solution storage scenarios, which led to a number of quantitative and qualitative recommendations.

**Dilute stored hypochlorite solutions on delivery.** The decomposition of hypochlorite and subsequent formation of chlorate and perchlorate are dependent on hypochlorite concentration and ionic strength. Higher ionic strength and hypochlorite concentration will drive the reaction toward greater production of chlorate and perchlorate while also increasing the rate of decomposition of hypochlorite. By diluting a 2-M hypochlorite solution by a factor of 2, the rate of perchlorate formation decreases by a factor of 7 because of the combined effects of concentration and ionic strength. If the same solution

is diluted by a factor of 4, the rate of perchlorate formation decreases by a factor of 36.

**Store hypochlorite solutions at lower temperatures.** Higher temperatures speed up the chemical decomposition of bleach and the subsequent formation of chlorate and perchlorate. Every 5°C reduction in storage temperature will reduce the rate of perchlorate formation by a factor of approximately 2. Thus, it would require close to a 15°C reduction in temperature to obtain the same effect as a simple 1:2 dilution. An illustration of the relative importance of temperature and dilution is provided elsewhere (Stanford et al, 2009).

**Control the pH of stored hypochlorite solutions at pH 11–13, even after dilution.** Storage of concentrated hypochlorite solutions at pH values < 11 is not recommended because of the rapid decomposition of hypochlorite/hypochlorous acid and the consequent formation of chlorate even though this reduces the amount of perchlorate formed. When the pH is > 13, perchlorate formation is enhanced because of the ionic strength effect. Therefore, utilities should con-

**TABLE 7** Control strategies and factors reducing the rate of perchlorate formation in hypochlorite solutions at pH 12

Parameter	Ratio/Amount				
	1:1	1:2	1:4	1:6	1:10
Dilution factor	1:1	1:2	1:4	1:6	1:10
FAC—%	13	6.5	3.3	2.2	1.3
OCl <sup>-</sup> —mol/L	2.0	1.0	0.50	0.33	0.20
ClO <sub>3</sub> <sup>-</sup> —mol/L	0.05	0.025	0.013	0.0083	0.005
Ionic strength—mol/L	6	3	1.5	1	0.6
Cooling—°C	Reduction Factor for Rate of ClO <sub>4</sub> <sup>-</sup> Formation				
0 (no cooling)	1.0	6.9	36	89	270
-1	1.1	7.9	41	100	300
-2	1.3	9.0	47	120	350
-3	1.5	10	54	130	400
-4	1.7	12	62	150	450
-5	1.9	13	71	170	520
-6	2.2	15	81	200	590
-7	2.6	18	93	230	680
-8	2.9	20	110	260	780
-9	3.4	23	120	300	900
-10	3.9	27	140	350	1,000
-11	4.5	31	160	400	1,200
-12	5.1	35	190	460	1,400
-13	5.9	41	210	530	1,600
-14	6.8	47	250	610	1,800
-15	7.9	54	290	700	2,100
-16	9.1	63	330	810	2,400
-17	11	73	380	940	2,800
-18	12	84	440	1,100	3,300
-19	14	98	510	1,300	3,800
-20	17	110	600	1,500	4,400

ClO<sub>3</sub><sup>-</sup>—chlorate, ClO<sub>4</sub><sup>-</sup>—perchlorate, FAC—free available chlorine, OCl<sup>-</sup>—hypochlorite

tinue to insist that manufacturer specifications include pH control in the range of 11 to 13.

**Use OSG and calcium hypochlorite solutions as soon as possible after manufacture/preparation.** Given the typical pH range of OSG bleach (pH 9–10), such solutions should be used as soon as possible after manufacture and should not be stored for more than one to two days. Because calcium hypochlorite will also form perchlorate after dissolution in water (similar to sodium hypochlorite), only freshly prepared solutions should be used.

**Control the removal of transition metal ions by purchasing filtered hypochlorite solutions and by using low-metal ion concentration feedwater and salt for the OSG systems.** The presence of transition metal ions results in an increased

degradation rate of hypochlorite. Although this degradation is concomitant with reduced perchlorate formation, the FAC concentration is also reduced, forcing a utility to use a higher volume of bleach that in turn results in higher mass loading of contaminants such as perchlorate, chlorate, and bromate.

**Avoid extended storage times, and use fresh hypochlorite solutions when possible.** Over time, bleach will naturally decompose to produce oxygen, chlorate, and perchlorate. Shorter storage times help minimize the formation of these contaminants in the hypochlorite solution. In addition, a fresh bleach solution contains a higher concentration of hypochlorite, thus reducing the amount of solution required to obtain the target chlorine residual. Again, higher

**FIGURE 2** Relationship between hypochlorite concentration and perchlorate formation in bulk hypochlorite

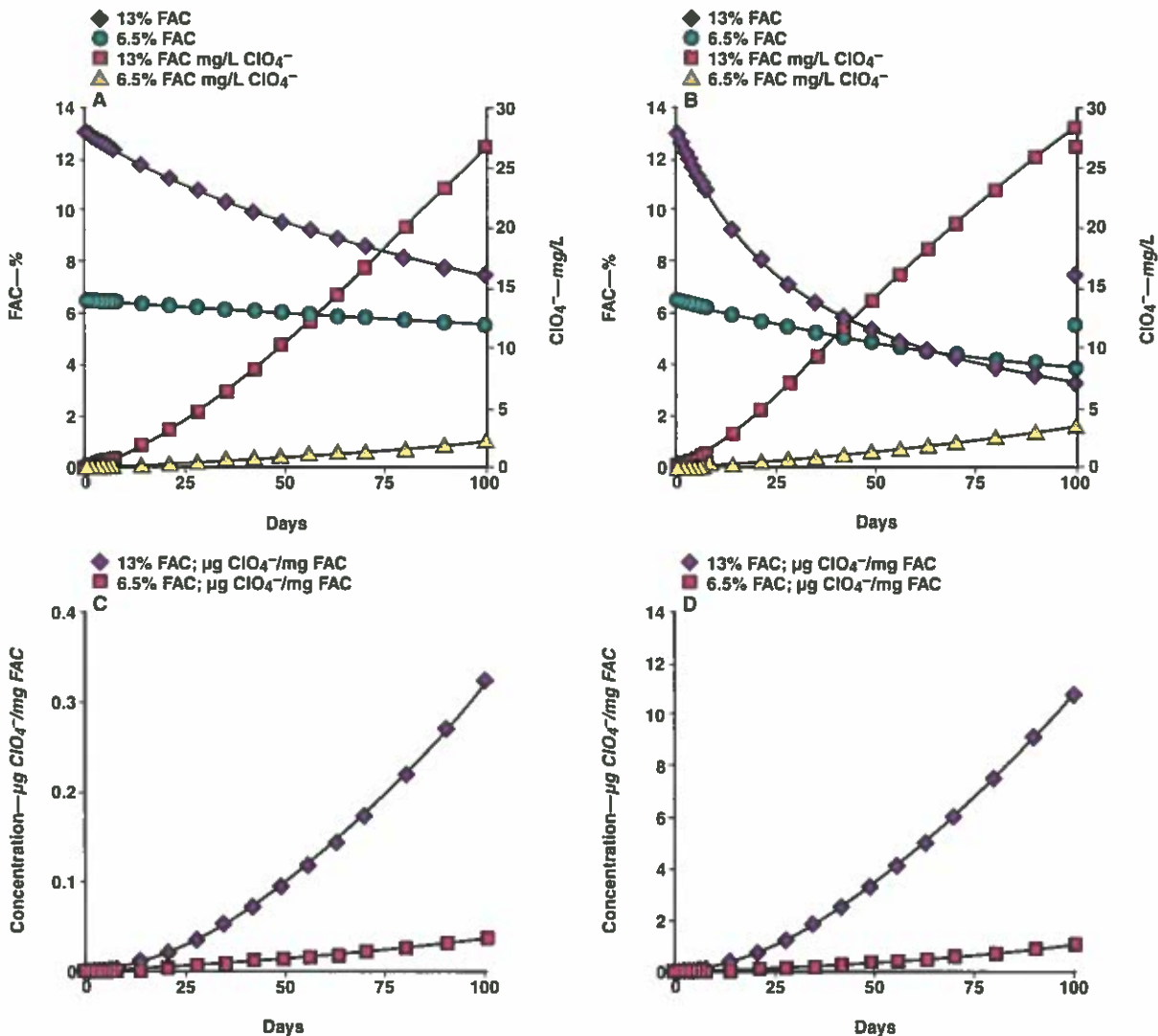

ClO<sub>4</sub><sup>-</sup>—perchlorate, FAC—free available chlorine

Parts A and C represent solutions at 25°C; Parts B and D represent solutions at 35°C.

hypochlorite concentration in fresh bleach will correspond to lower concentrations of contaminants dosed.

**For utilities using OSG bleach, use high-purity salt to minimize the amount of bromide present in the brine.** Bromate formation will occur rapidly in hypochlorite solutions in the presence of bromide. By controlling the amount of bromide in the salt and source water used for onsite generation, bromate formation can be minimized.

## SUMMARY

On the basis of the information provided here, three potential sources of contamination for perchlorate and other oxyhalide ions were identified:

- background contamination from nearby agricultural activity, industrial/military sites, and/or natural deposits;
- formation during the treatment process itself (e.g., bromide conversion to bromate during ozonation); and
- via addition during the use of hypochlorite solutions containing perchlorate, chlorate, and bromate during the water treatment process.

A recent article (Russell et al, 2009) estimated that a federal perchlorate regulation of 4 µg/L would result in an annual cost of approximately \$76 million–\$140 million per year, a cost borne by only 3.4% of public water systems. The numbers generated in that report, however,

assumed that all perchlorate detected in the finished water was also present in the raw water and would need to be removed by one or more treatment technologies. Evidence from the predictive model and measured perchlorate contamination in hypochlorite solutions indicated significant potential for a 4-µg/L regulation to be exceeded. Greiner and colleagues (2008) suggested that five out of 82 bulk sodium hypochlorite solutions tested had enough perchlorate present to result in more than 4 µg/L of additional perchlorate in the finished water (above and beyond any background contamination) based on the maximum use level (MUL) of 10 mg/L FAC (NSF/ANSI, 2005). Although the 10-mg/L FAC MUL may be unrealistic for many utilities, results from the model used in the current study indicated the potential contribution of perchlorate and chlorate from hypochlorite can be significant when proper storage and handling procedures are not followed.

Therefore, careful control of the quality of hypochlorite used in drinking water treatment could be equally, if not more, important for utilities operating near or above any potential federal or state MCLs resulting from source water contamination. Furthermore, utilities should be aware that the quality of hypochlorite (i.e., perchlorate, chlorate, bromate, and metal ion concentrations) being

## REFERENCES

- Adam, L.C., 1994. An Investigation of the Factors Involved in the Decomposition of Sodium Hypochlorite. Doctoral dissertation, Miami University, Oxford, Ohio.
- Adam, L.C., Gordon, G. & Pierce, D., 2001. Bleach 2001. AwwaRF and AWWA, Denver.
- Adam, L.C. & Gordon, G., 1999. Hypochlorite Ion Decomposition: Effects of Temperature, Ionic Strength, and Chloride Ion. *Inorganic Chem.*, 38:6:1299.
- Aribi, H.E.; Le Blanc, Y.J.C.; Antonsen, S.; & Sakumaa, T., 2006. Analysis of Perchlorate in Foods and Beverages by Ion Chromatography Coupled With Tandem Mass Spectrometry (IC–ESI–MS/MS). *Analytica Chimica Acta*, 567:39.
- Asami, M.; Kosaka, K.; & Kunikane, S., 2009. Bromate, Chlorate, Chlorite, and Perchlorate in Sodium Hypochlorite Solution Used for Water Supply. *Jour. Water Supply Res. & Technol.—Aqua*, 58:2:107.
- Baier-Anderson, C.; Blount, B.C.; Lakind, J.S.; Naiman, D.Q.; Wilbur, S.B.; & Tan, S., 2006. Estimates of Exposures to Perchlorate From Consumption of Human Milk, Dairy Milk, and Water, and Comparison to Current Reference Dose. *Jour. Toxicol. & Envir. Health—Part A*, 69:319.
- CDPH (California Department of Public Health, 2007). Perchlorate in Drinking Water. [www.cdph.ca.gov/certlic/drinkingwater/pages/Perchlorate.aspx](http://www.cdph.ca.gov/certlic/drinkingwater/pages/Perchlorate.aspx) (accessed Nov. 14, 2009).
- Gordon, G. & Bubnis, B., 2000. Sodium Hypochlorite Specifications. Proc. 2000 AWWA Ann. Conf., Denver.
- Gordon, G.; Adam, L.C.; Bubnis, B.P.; Kuo, C.; Cushing, R.S.; & Sakaji, R.H., 1997. Predicting Liquid Bleach Decomposition. *Jour. AWWA*, 89:4:142.
- Gordon, G.; Adam, L.C.; & Bubnis, B.P., 1995. Minimizing Chlorate Ion Formation in Drinking Water When Hypochlorite Ion Is the Chlorinating Agent. *Jour. AWWA*, 87:6:97.
- Gordon, G.; Adam, L.C.; Bubnis, B.P.; Hoyt, B.; Gillette, S.J.; & Wilczak, A., 1993. Controlling the Formation of Chlorate Ion in Liquid Hypochlorite Feedstocks. *Jour. AWWA*, 85:9:89.
- Greer, M.A.; Goodman, G.; Pleus, R.C.; & Greer, S.E., 2002. Health Effects Assessment for Environmental Perchlorate Contamination: The Dose–Response for Inhibition of Thyroidal Radioiodine Uptake in Humans. *Envir. Health Perspectives*, 110:9:927.
- Greiner, P.; McClellan, C.; Bennett, D.; & Ewing, A., 2008. Occurrence of Perchlorate in Sodium Hypochlorite. *Jour. AWWA*, 100:11:68.
- Howd, R.H., 2002. Memorandum: Proposed Action Level for Chlorate. Calif. Dept. of Envir. Health Hazard Assessment, Sacramento. [oehha.ca.gov/water/pals/chlorate.html](http://oehha.ca.gov/water/pals/chlorate.html) (accessed May 23, 2011).
- Jackson, L.P., 2011. Drinking Water: Regulatory Determination on Perchlorate. Dockets EPA-HQ-OW-2008-0692, EPA-HQ-OW-2009-0297; FRL-9262-8, *Fed. Reg.*, 76:29:7762. Washington. [www.gpo.gov/fdsys/pkg/FR-2011-02-11/pdf/2011-2603.pdf](http://www.gpo.gov/fdsys/pkg/FR-2011-02-11/pdf/2011-2603.pdf).
- Lamm, S.H.; Braverman, L.E.; Li, F.X.; Richman, K.; Pino, S.; & Howearth, G., 1999. Thyroid Health Status of Ammonium Perchlorate Workers: A Cross-Sectional Occupational Health Study. *Jour. Occupational & Envir. Medicine*, 41:4:248.
- MDEP (Massachusetts Department of Environmental Protection), 2006. Drinking Water Regulations and Standards. [www.mass.gov/dep/water/drinking/percinfo.htm#stds](http://www.mass.gov/dep/water/drinking/percinfo.htm#stds) (accessed Nov. 14, 2009).
- NJDEP (New Jersey Department of Environmental Protection), 2010. DEP Delays Adopting Perchlorate Standard Pending Federal

delivered to their facility could be affected by the conditions under which the hypochlorite was stored after manufacture and before delivery.

## ACKNOWLEDGMENT

Funding for this study was provided by the AWWA Water Industry Technology Action Fund (project 712) and the Water Research Foundation (project 4147). The authors thank Oscar Quinones, Janie Holady, Shannon Ferguson, Christy Meza, Dave Rexing, and other staff at the Southern Nevada Water Authority in Las Vegas for their assistance with various aspects of this project. The authors also thank the many utility and industry participants who provided samples and support for this project.

## ABOUT THE AUTHORS



*Benjamin D. Stanford (to whom correspondence should be addressed) is director of applied research at Hazen and Sawyer, 4011 Westchase Blvd., Ste. 500, Raleigh, NC; bstanford@hazenandsawyer.com. He holds a BS in chemistry from Warren Wilson College in Asheville,*

*N.C., and a PhD in environmental sciences and engineering from the University of North Carolina at Chapel Hill. He has more than 13 years of experience in environmental chemistry and drinking water and wastewater quality in such areas as chlorine chemistry, water reuse, reduction of organic fouling in membrane systems, and fate and transport of micropollutants. Aleksey N. Pisarenko is a postdoctoral researcher at the Southern Nevada Water Authority's Applied Research and Development Center in Las Vegas. Shane A. Snyder is a professor in the Department of Chemical and Environmental Engineering at the University of Arizona in Tucson. Gilbert Gordon is professor emeritus in the Department of Chemistry at Miami University, Oxford, Ohio.*

Date of submission: 04/05/10

Date of acceptance: 02/11/11

Direction. [www.state.nj.us/dep/newsrel/2010/10\\_0017.htm](http://www.state.nj.us/dep/newsrel/2010/10_0017.htm) (accessed Mar. 18, 2010).

NJDEP, 2009. Notice of Rule Proposal: Private Well Testing Act Rules, Safe Drinking Water Act Rules, Regulations Governing the Certification of Laboratories and Environmental Measurements, NJAC. 7:9e-2.1, 4.1; 7:10-5.1; 12.30, 7:18-5.6; 9.4. [www.state.nj.us/dep/rules/notices/031609a.html](http://www.state.nj.us/dep/rules/notices/031609a.html) (accessed May 23, 2011).

NSF/ANSI, 2005. NSF/ANSI Standard 60: Drinking Water Treatment Chemicals—Health Effects. NSF International, Ann Arbor, Mich.

Pisarenko, A.N.; Stanford, B.D.; Quiñones, D.; Pacey, G.E.; Gordon, G.; & Snyder, S.A., 2010. Rapid Analysis of Perchlorate, Chlorate, and Bromate Ions in Concentrated Sodium Hypochlorite Solutions. *Analytica Chimica Acta*, 659:1-2:216.

Routt, J.C.; Mackey, E.; Whitby, G.E.; & Noak, R., 2008a. Committee Report: Disinfection Survey, Part 1—Recent Changes, Current Practices, and Water Quality. *Jour. AWWA*, 100:10:76.

Routt, J.C.; Mackey, E.; Whitby, G.E.; & Noak, R., 2008b. Committee Report: Disinfection Survey, Part 2—Alternatives, Experiences, and Future Plans. *Jour. AWWA*, 100:11:110.

Russell, C.G.; Roberson, J.A.; Chowdhury, Z.; & McGuire, M.J., 2009. National Cost Implications of a Perchlorate Regulation. *Jour. AWWA*, 101:3:54.

Silva, P.S., 2009. Drinking Water: Perchlorate Supplemental Request for Comments. [www.epa.gov/fedrgstr/EPA-WATER/2009/August/Day-19/w19507.pdf](http://www.epa.gov/fedrgstr/EPA-WATER/2009/August/Day-19/w19507.pdf) (accessed Oct. 1, 2009).

Snyder, S.A.; Stanford, B.D.; Pisarenko, A.N.; Gilbert, G.; & Asami, M., 2009. Hypochlorite—An Assessment of Factors That Influence the Formation of Perchlorate and Other Contaminants. AWWA and Water

Research Foundation Rept. [www.awwa.org/files/GovtPublicAffairs/PDF/HypochloriteAssess.pdf](http://www.awwa.org/files/GovtPublicAffairs/PDF/HypochloriteAssess.pdf) (accessed May 23, 2011).

Snyder, S.A.; Pleus, R.C.; Vanderford, B.J.; & Holaday, J.C., 2006. Perchlorate and Chlorate in Dietary Supplements and Flavor-Enhancing Ingredients. *Analytica Chimica Acta*, 567:1:26.

Snyder, S.A.; Vanderford, B.J.; & Rexing, D.J., 2005. Trace Analysis of Bromate, Chlorate, Iodate, and Perchlorate in Natural and Bottled Waters. *Envir. Sci. & Technol.*, 39:12:4586.

Stanford, B.D.; Pisarenko, A.N.; Snyder, S.A.; & Gordon, G., 2009. Minimize Perchlorate in Hypochlorite Solutions. *Opflow*, 35:10:10.

Tiemann, M., 2008. Perchlorate Contamination of Drinking Water: Regulatory Issues and Legislative Actions. CRS Rept. for Congress RS21961. [ncseonline.org/NLE/CRSreports/08Mar/RS21961.pdf](http://ncseonline.org/NLE/CRSreports/08Mar/RS21961.pdf) (accessed May 23, 2011).

Urbansky, E.T., 2000. Perchlorate in the Environment. *Envir. Sci. Res.*, 57:299.

USEPA (US Environmental Protection Agency), 2006. Draft Regulatory Determinations Support Document for Selected Contaminants From the Second Drinking Water Contaminant Candidate List. Chapter 12: Perchlorate. USEPA, Ofce. of Water, Washington.

USEPA, 2002. Perchlorate Environmental Contamination: Toxicological Review and Risk Characterization (2002 External Review Draft). Rept. NCEA-1-0503. USEPA, Ofce. of Res. and Devel., Natl. Ctr. for Envir. Assessment, Washington.

Weinberg, H.S.; Delcomyn, C.A.; & Unnam, V., 2003. Bromate in Chlorinated Drinking Waters: Occurrence and Implications for Future Regulation. *Envir. Sci. & Technol.*, 37:14:3104.

York, R.G.; Brown, W.R.; Girard, M.F.; & Dollarhide, J.S., 2001. Oral (Drinking Water) Developmental Toxicity Study of Ammonium Perchlorate in New Zealand White Rabbits. *Intl. Jour. Toxicol.*, 20:199.



**MesaWater**  
DISTRICT<sup>©</sup>

**Hazen**

Hazen and Sawyer  
11260 El Camino Real • Suite 102 • San Diego, CA 92130